

Type _____
 -09 -20
 P4434

Catalog No.	Finish		Lamping	Dimensions (Inches)		
	Brushed Nickel	Antique Bronze		A	B	C
P4434	-09	-20	3 (m) 100w	13	20-1/2	95

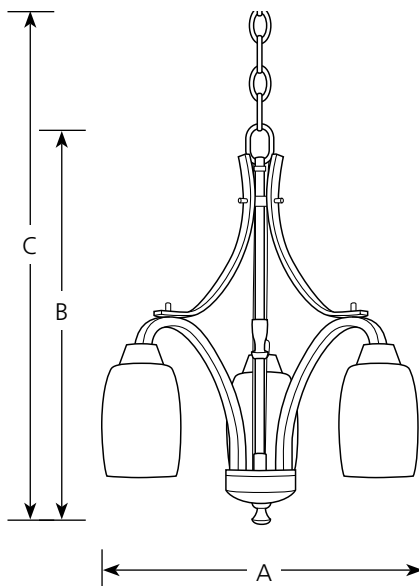

Specifications:

General

- Etched glass tulip shaped shades (4" dia., 5-1/4" ht., 1-5/8" center hole)
- Downlight style chandelier
- Strap style arms and accents
- Six feet of 9 gauge chain supplied
- Brushed Nickel (-09) is plated
- Antique Bronze (-20) is hand painted
- Steel construction
- Companion chandelier, hall and foyer, wall bracket, close to ceiling, pendant, and bath and vanity units

Mounting

- Ceiling chain mounted
- Canopy covers a standard 4" hexagonal outlet box
- Mounting strap for outlet box included

Electrical

- Ceramic medium based sockets
- 15 feet of wire
- Pre-wired

Labeling

- UL-CUL listed