

Type _____
 -31
 P5234
 P5235

Catalog No.	Finish Black	Lamping	Dimensions (Inches)	
			A	B
P5234	-31	1-50w PAR20	4-1/2	6-5/8
P5235	-31	1-150w PAR38	5-1/4	8-1/4

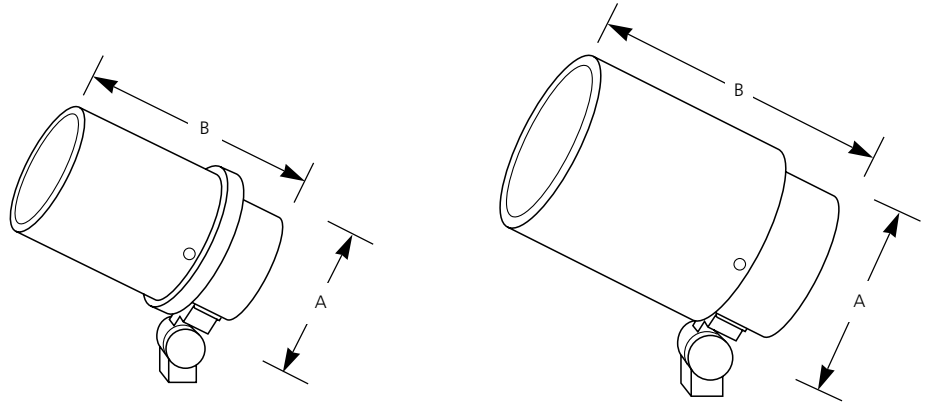

Specifications:

General

- Die cast aluminum construction
- Lens cover assembly removable for relamping
- Black powder coat paint finish
- Sealed clear lens
- Positive adjustment with stainless steel locking screw for aiming
- Accessory light shields (P8612 & P8614) & cube cell louvers (P8611 & P8613) available

Mounting

- Mounts on landscape post (P8562-31), stake (P5233-31) or approved weatherproof box (order separately)
- 1/2 NPS thread

Electrical

- Medium based porcelain socket
- Pre-wired

Labeling

- UL-CUL wet location listed