

Type \_\_\_\_\_  
 -09EBWB -174EBWB  
 P7083

Catalog No.	Finish	Lamping	Socket	Dimensions (Inches)		
	Brushed Nickel			A	B	C
P7083	-09EBWB	1-26w 4 pin Quad Included	G24q2	8-7/8	10-5/8	3-7/8
	-174EBWB	1-26w 4 pin Quad Included	G24q2	8-7/8	10-5/8	3-7/8

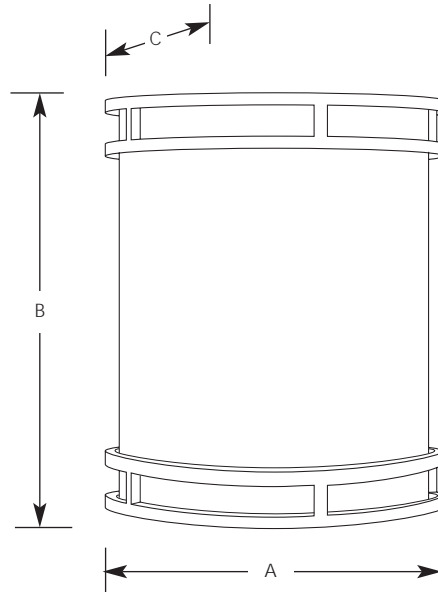

**Specifications:**

General

- White Acrylic diffuser
- UP and down lighting
- Translucent acrylic top and closed bottom
- Brushed and polished nickel trim
- Plated finish on trim
- Steel construction
- Meets ADA (Americans with disabilities act) requirements when wall mounted.
- Certified Energy Star product

Electrical

- Pre-wired
- 120 volt NPF electronic ballast

Labeling

- UL-CUL listed for damp locations

Mounting

- Vertical wall mount
- Covers outlet box
- Mounting strap for outlet box included



Progress Lighting  
 Post Office Box 5704  
 Spartanburg, South Carolina  
 29304-5704