

CK1225T0TX
Pyramid End Table
Assembly Instructions



For

to:

Southern Enterprises Inc.
Customer Service 1-800-633-5096
service@seidal.com
www.seidal.com

PO#11838

Max Top Load 40 lbs.

Max Load Inside the Trunk 60 lbs.

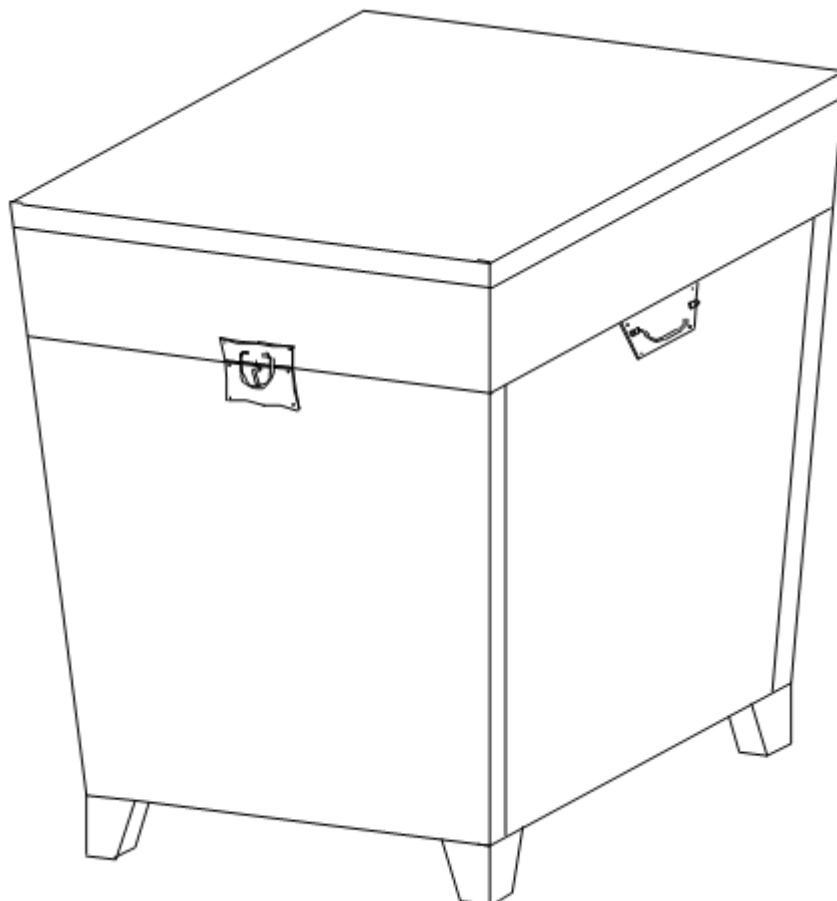

CK1225T0TX Pyramid End Table Parts List

Please review all parts and hardware before disposing of any packaging.
Call Customer Service if missing hardware. Do not return to store/retailer.
Using a screw that is too long will cause damage. Before beginning assembly,
separate each type of screw. Carefully study the screw diagrams below

A

1 PC

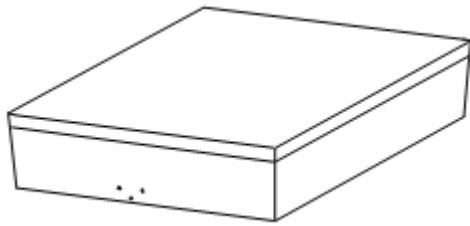

Top

B

1 PC

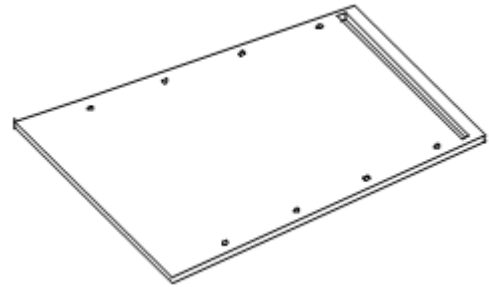

Front Panel

C

1 PC

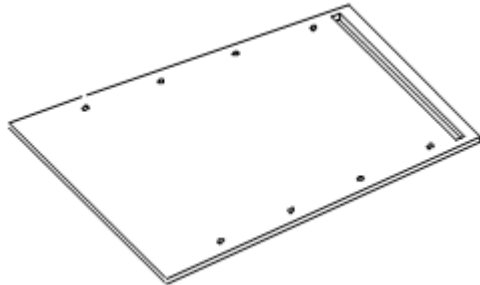

Back Panel

D

2 PCS

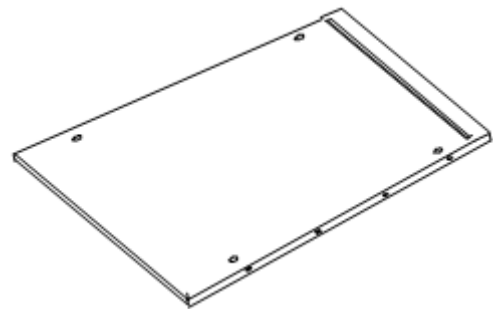

Side Panel

E

1 PC

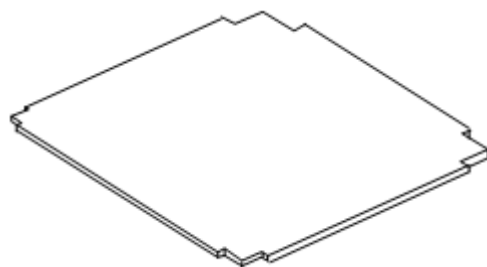



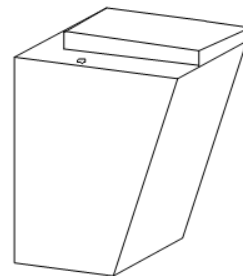

Bottom Panel

F

4 PCS

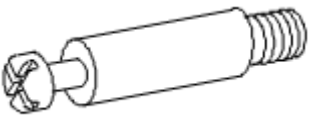

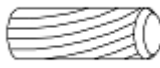
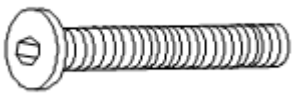
Leg

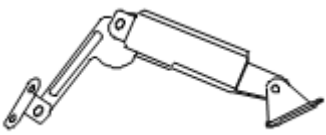
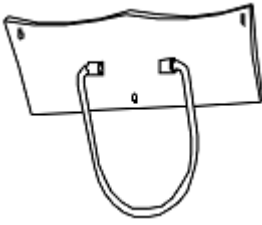
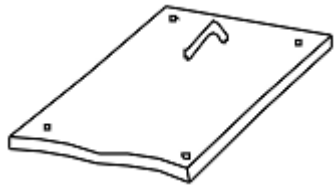
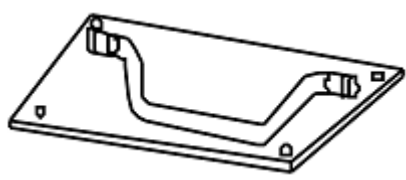
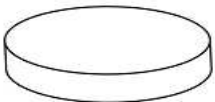
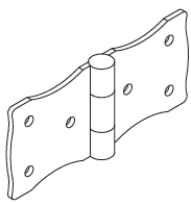
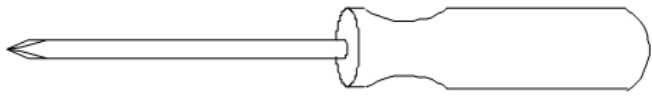
<p>G 8 PCS</p>  <p>Small Cam Screw φ6.8 x 36mm</p>	<p>H 8 PCS</p>  <p>Small Cam Lock φ15 x 12mm</p>	<p>I 1 PC</p>  <p>Wrench</p>
<p>J 8 PCS</p>  <p>Dowel φ8 x 30mm</p>	<p>K 8 PCS</p>  <p>Bolt φ 1/4" x 2 3/4"</p>	<p>L 31 PCS</p>  <p>Screw φ 3.5 x 16mm</p>
<p>M 1 PC</p>  <p>Support</p>	<p>N 1 PC</p>  <p>Handle-A</p>	<p>O 1 PC</p>  <p>Handle-B</p>
<p>P 2 PCS</p>  <p>Handle</p>	<p>Q 10 PCS</p>  <p>Sponge Cushion</p>	<p>R 2 PCS</p>  <p>Hinge</p>
<p>Care and Cleaning Instructions: Before using, wipe with a clean dry cloth. Periodically apply furniture wax to renew the finish. Avoid rubbing or scratching the surface with rough or abrasive objects.</p>		<p>For replacement parts or questions, please call Customer Service at 1-800-633-5096. Do not return product to store. Please call manufacturer for assistance, questions or parts.</p>
<p>Assembly Tool Required No.2 Phillips Screwdriver</p>		

CK1225T0TX

Pyramid End Table

Assembly Instructions

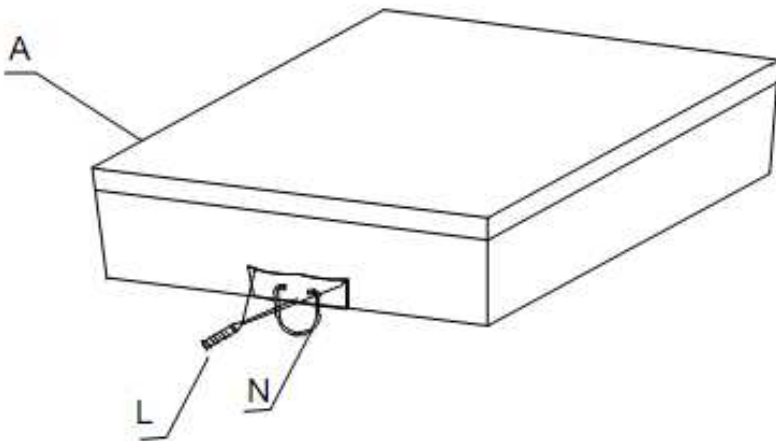

PLEASE DO NOT OVER-TIGHTEN
CAMBOLTS. PLEASE STOP WHEN
YOU FEEL TIGHT

Step 1:
Put all parts on a soft surface
to prevent scratches.
Attach handle-A (N) to the top
(A) using screws (L) and
tighten with Phillips
screwdriver as shown.

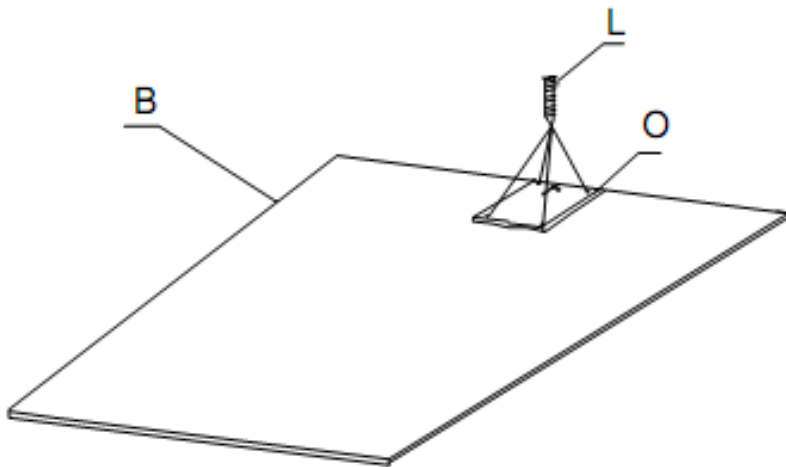

Step 2:
Attach handle-B (O) to front
panel (B) using screws (L)
and tighten with Phillips
screwdriver as shown.

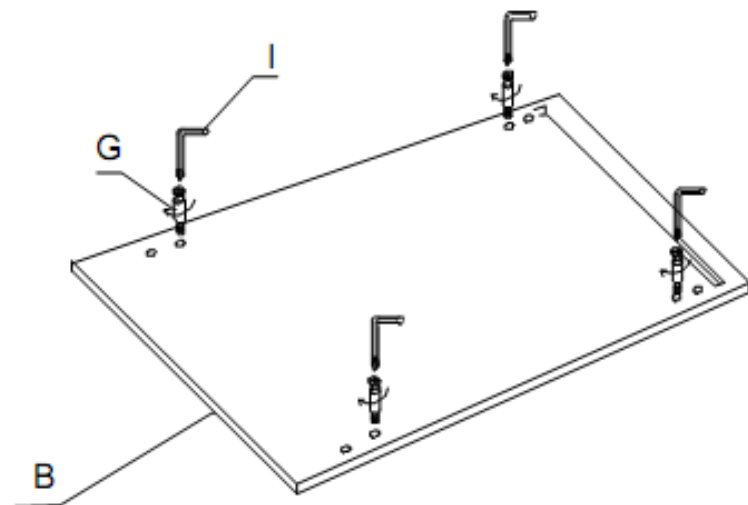

Step 3:
Screw small cam screws (G)
into front panel (B) as shown.

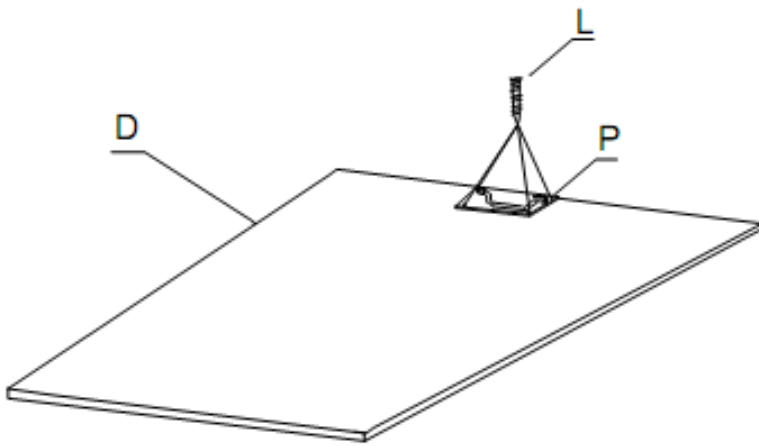

Step 4:

Attach handles (P) to left side panels (D) using screws (L) and tighten with phillips screwdriver as shown.

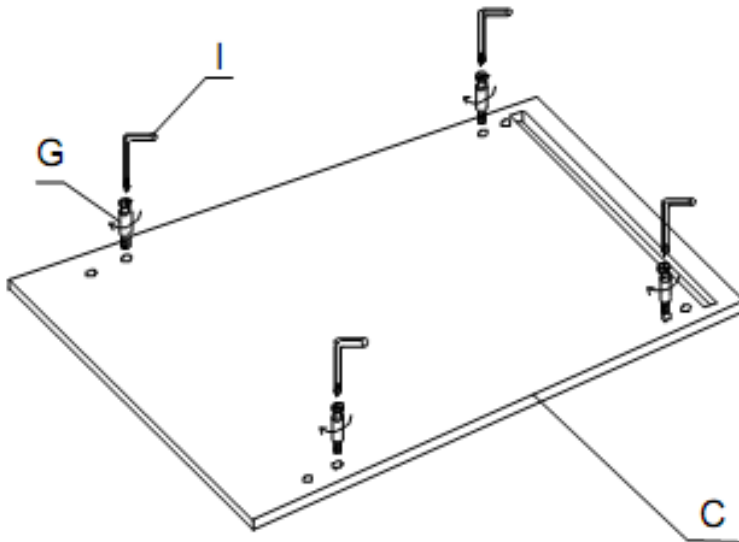

Step 5:

Screw small cam screws (G) into back panel (C) as shown.

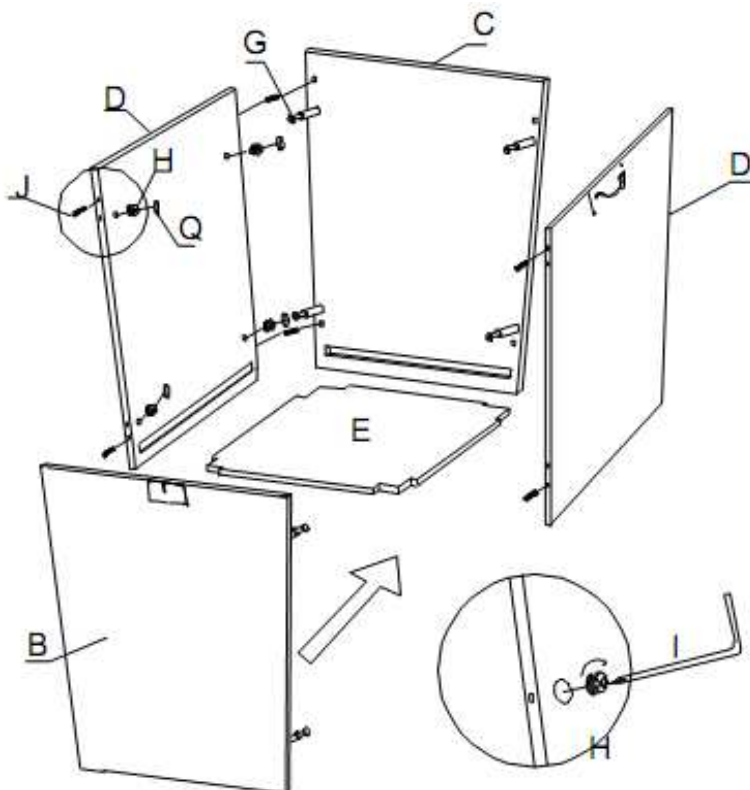

Step 6:

Insert dowels (J) into side panels (D) as shown.

Assemble side panels (D), front panel (B), back panel (C) and bottom panel (E) together using small cam screws (G), small cam locks (H), dowels (J) and sponge cushions (Q) as shown.

Make sure the edges of bottom panel (E) are inserted into the grooves of all panels.

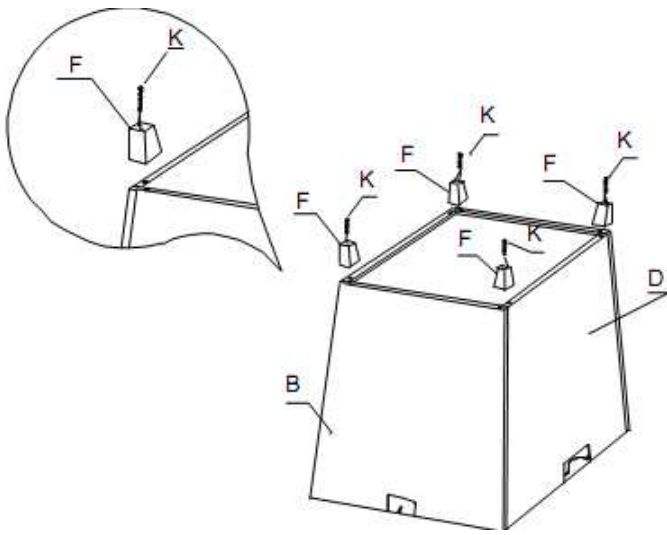

Step 7:
 Turn the trunk base upside down and attach legs (F) to the bottom of trunk using screws (K) as shown.

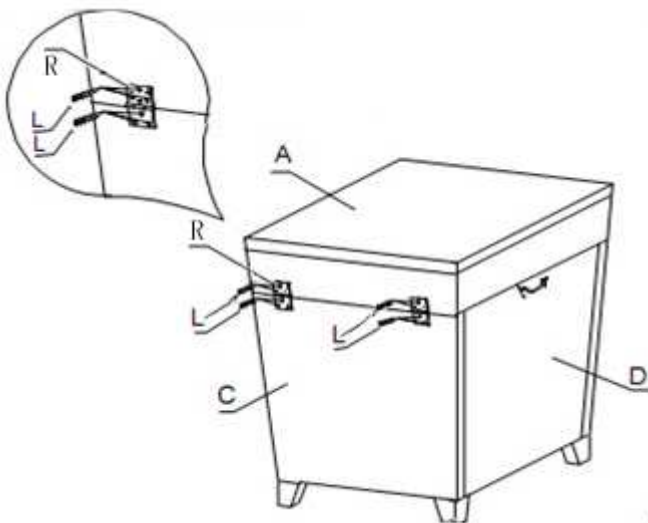

Step 8:
 Attach Hinge (R) to back panel (C) and top panel (A) by using screws (L) as shown and then tighten all screw by phillips screwdriver(not included)

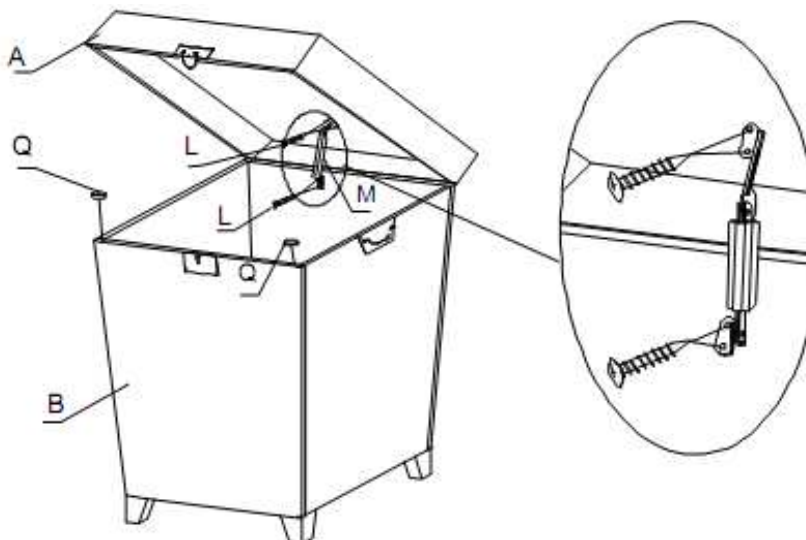

Step 9:
 Attach support (M) to the top (A) and trunk base using screws (L) and tighten with Phillips screwdriver as shown.

Put sponge cushions (Q) on front panel (B) as shown. Close the top. Top will close slowly.

Parts Replacement Form

Customer Information

Name _____

Address _____

City/State/Zip Code _____

Phone Number _____

Please indicate where you purchased this item: Store/Website/Catalog

Please indicate color/size/style number:

Style No	Parts Letter	Parts Description	Quantity Needed
_____	_____	_____	_____
_____	_____	_____	_____
_____	_____	_____	_____

Please immediately examine this product carefully. Any request for missing parts or damage replacement must be received within 90 days of your receipt of the product. Replacement, if available, will be honored within this time frame. Parts will not be available for items arriving fully assembled. We do not recommend modifying product(s) and we are not responsible for any damages due to product modification(s). If damages or missing parts are not reported within 90 days of your receipt, we are under no obligation to provide parts or replacement merchandise.

Please contact Southern Enterprises at 800-633-5096 or in Dallas 972-869-0111/ 9am – 4pm Mon-Fri Central time if you have product issues or email us at service@seidal.com. Please ask for customer service representative for issues involving damages or replacement parts. Please ask for technical assistance representative for any issues with product and assembly/construction.

Please contact the retailer that you purchased from for returns.



Customer Service 1-800-633-5096

service@seidal.com

Southern Enterprises, Inc.

600 Freeport Parkway, Suite 200

Coppell, Texas 75019