

HO664200TX – White
HO664300TX– Black
HO664400TX- Espresso
Corner Desk
Assembly Instructions



Southern
ENTERPRISES

For assistance with assembly contact:
Southern Enterprises Inc.
Customer Service 1-800-633-5096
service@seidal.com
www.seidal.com



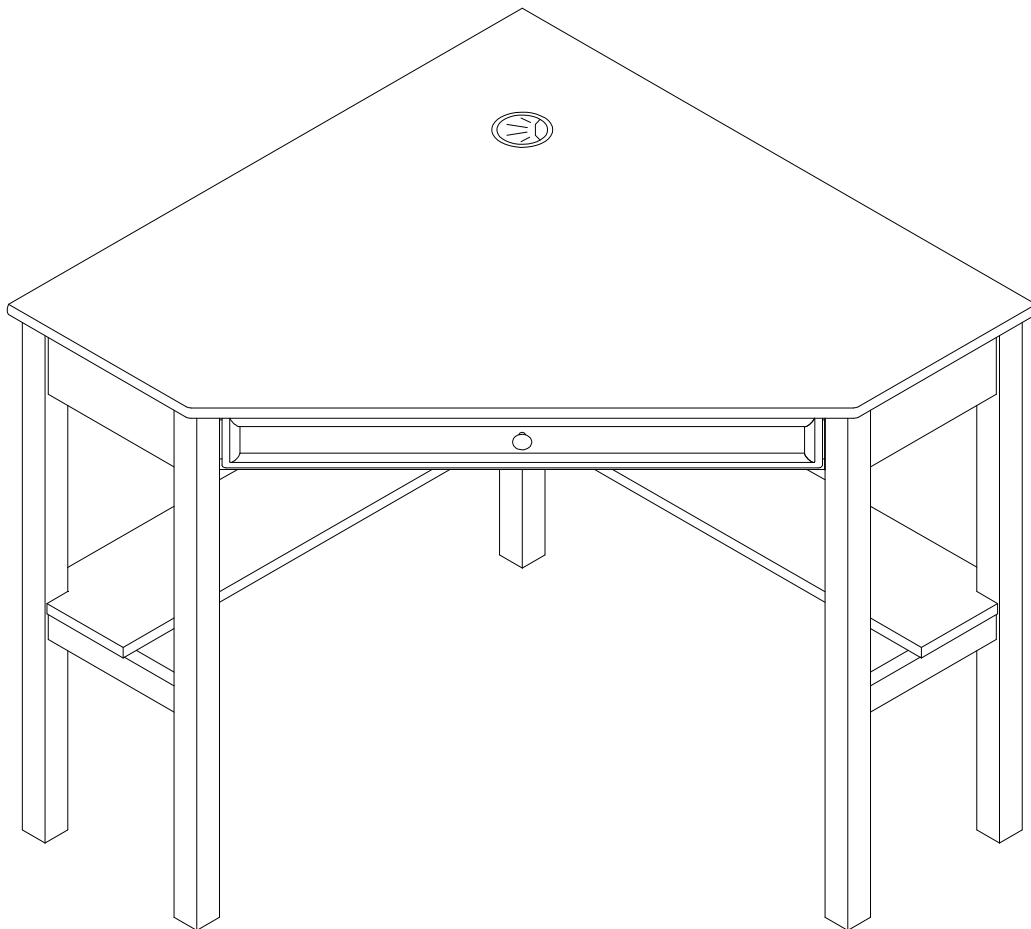

PO#11279

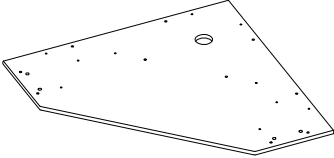
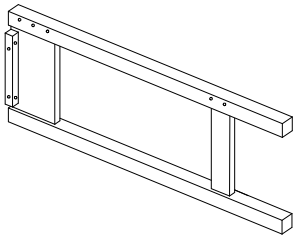
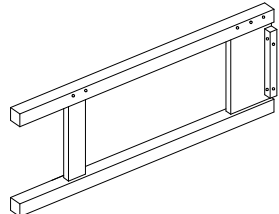
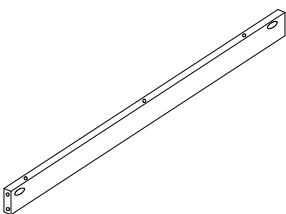
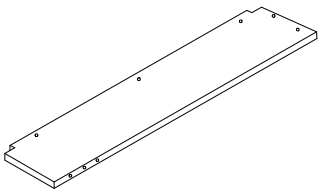
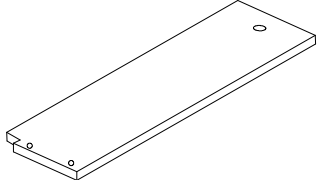
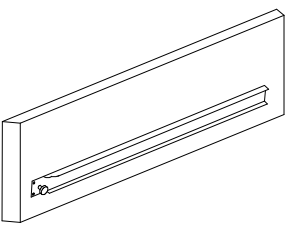
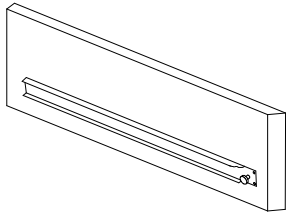
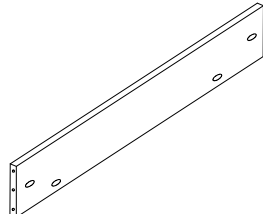
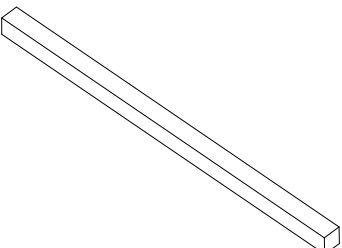
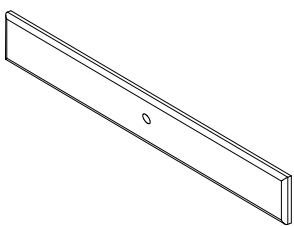
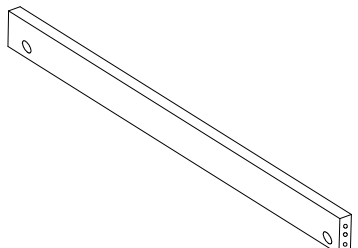
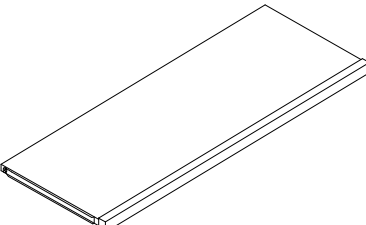
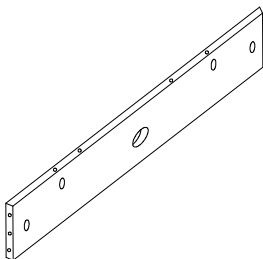

Corner Desk Parts List

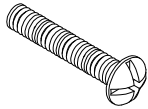
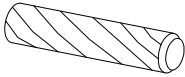
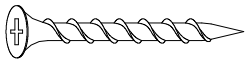
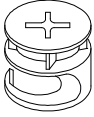
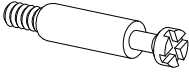
Please check packaging for all parts and hardware before discarding. Unpack and lay parts on clean, padded surface like carpet or blanket. Check that you have all parts indicated. Call customer service if hardware is missing. Before beginning assembly, carefully study the diagrams below and sort your hardware according to the pictures. Using the incorrect hardware will cause damage.

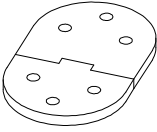
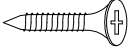
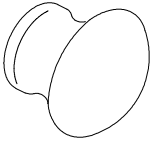
<p>A 1pc</p>  <p>Wood Top</p>	<p>B 1pc</p>  <p>Left Side Leg</p>	<p>C 1pc</p>  <p>Right Side Leg</p>
<p>D 2pcs</p>  <p>Bottom Stretcher</p>	<p>E 1pc</p>  <p>Left Long Shelf</p>	<p>F 1pc</p>  <p>Right Short Shelf</p>
<p>G 1pc</p>  <p>Drawer Right Panel</p>	<p>H 1pc</p>  <p>Drawer Left Panel</p>	<p>I 2pcs</p>  <p>Back Panel</p>
<p>J 1pc</p>  <p>Back Leg</p>	<p>K 1pc</p>  <p>Drawer Front Panel</p>	<p>L 1pc</p>  <p>Drawer Front Stretcher</p>
<p>M 1pc</p>  <p>Drawer Shelf</p>	<p>N 1pc</p>  <p>Drawer Back Panel</p>	

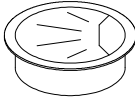
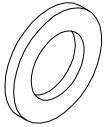
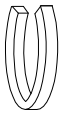
<p>1 4pcs</p>  <p>Bolt $\text{\O}1/4\text{''} \times 1\text{-}1/4\text{''} \text{L}$</p>	<p>2 32pcs</p>  <p>Wood Dowel</p>	<p>3 10pcs</p>  <p>Screw $\text{\O}5/32\text{''} \times 1\text{''} \text{L}$</p>
<p>4 23pcs</p>  <p>Cam Lock</p>	<p>5 23pcs</p>  <p>Cam Bolt</p>	<p>6 23pcs</p>  <p>Cover</p>
<p>7 2pcs</p>  <p>Hinge</p>	<p>8 12pcs</p>  <p>Screw $\text{\O}1/8\text{''} \times 1/2\text{''} \text{L}$</p>	<p>9 1pc</p>  <p>Wood Knob</p>
<p>10 1pc</p>  <p>Bolt $\text{\O}5/32\text{''} \times 1\text{''} \text{L}$</p>	<p>11 1pc</p>  <p>Plastic Cap</p>	<p>12 4pcs</p>  <p>Flat Washer</p>
<p>13 4pcs</p>  <p>Lock Washer</p>		

Care and Cleaning Instructions:

Before using, wipe with a clean, dry cloth. Periodically apply furniture wax to renew the finish. Avoid rubbing or scratching the surface with rough or abrasive objects.

For replacement parts or questions, please call customer service at 1-800-633-5096.

**Assembly Tool Required
No.2 Phillips Screwdriver
(not included)**

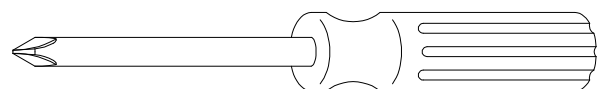

Corner Desk Assembly Instructions

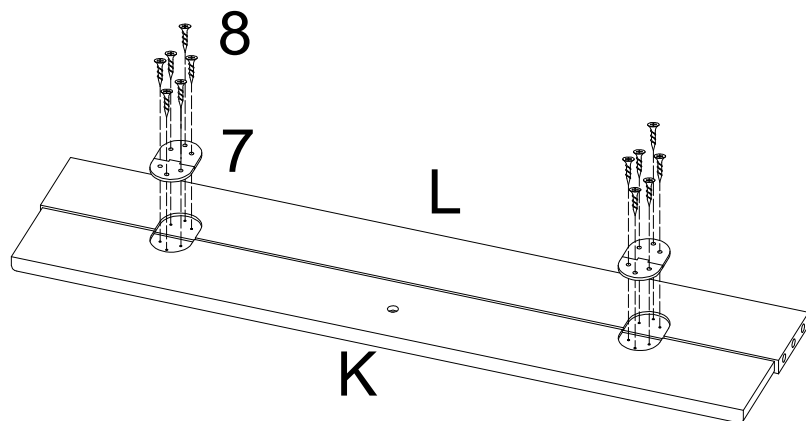

Figure 1

Please do not over-tighten cam locks.
Please stop when you feel them
tighten.

Attach hinges (7) to drawer front panel
(K) and drawer front stretcher (L) by
using screws (8) as shown.

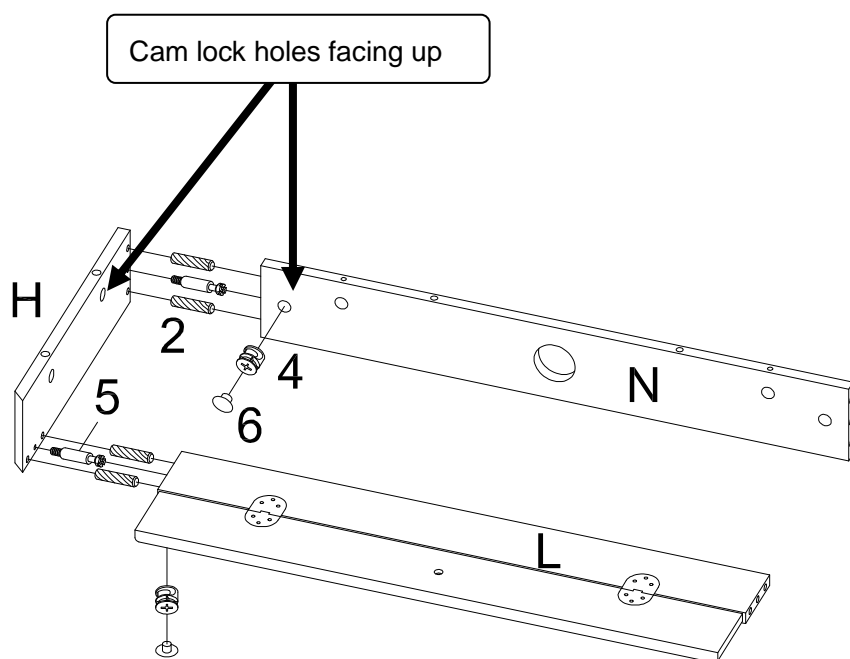
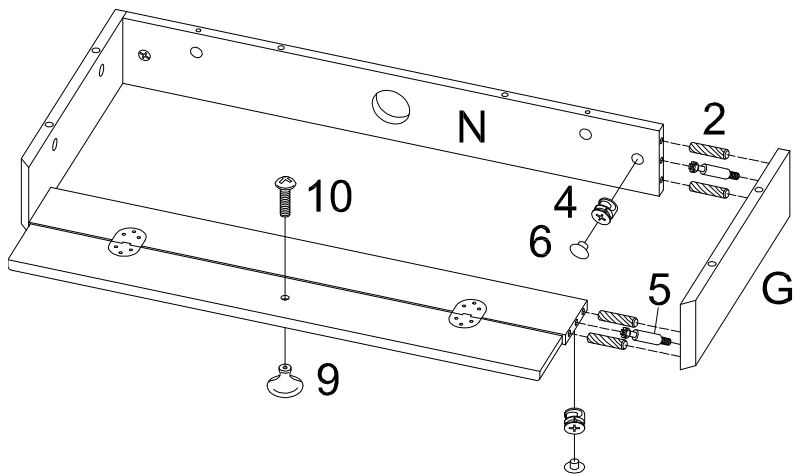

Figure 2

Insert cam locks (4) into holes on
drawer back panel (N) and drawer front
stretcher (L). Screw cam bolts (5) into
holes on drawer right panel (G). The
cam lock hole for drawer front stretcher
(L) should be facing down as shown on
the illustration. Make sure the holes for
the cam locks on drawer right panel (G)
and drawer back panel (N) are facing
upwards as shown.

Attach drawer **left panel (H)** to drawer
back panel (N) and drawer front
stretcher (L) by inserting wood dowels
(2) and cam bolts (5) into
corresponding holes until drawer right
panel (G), drawer back panel (N), and
drawer front stretcher (L) meet.

Tighten by rotating cam locks (4)
clockwise with Phillips screwdriver.
Make sure not to over tighten.



Repeat the same procedure as above to attach drawer **right side panel (G)** to drawer back panel (N) and drawer front stretcher (L). Make sure the cam lock holes are facing upwards.

Cover cam lock holes with covers (6).

Then attach wood knob (9) to drawer front panel (K) by using screw (10).

Figure 3

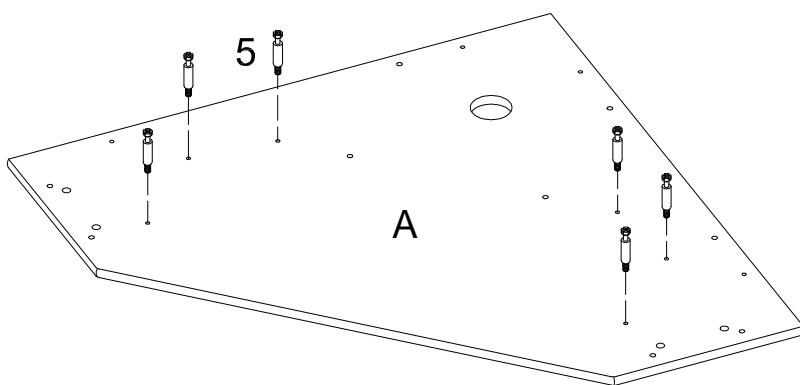

Screw cam bolts (5) into corresponding holes on the bottom of wood top (A).

Figure 4

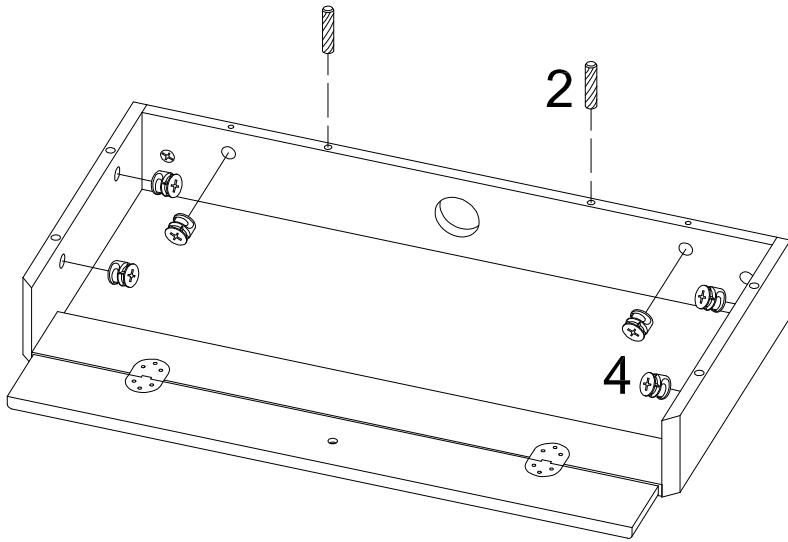

Figure 5

Insert cam locks (4) and wood dowels (2) into corresponding holes on assembled unit from figure 3.

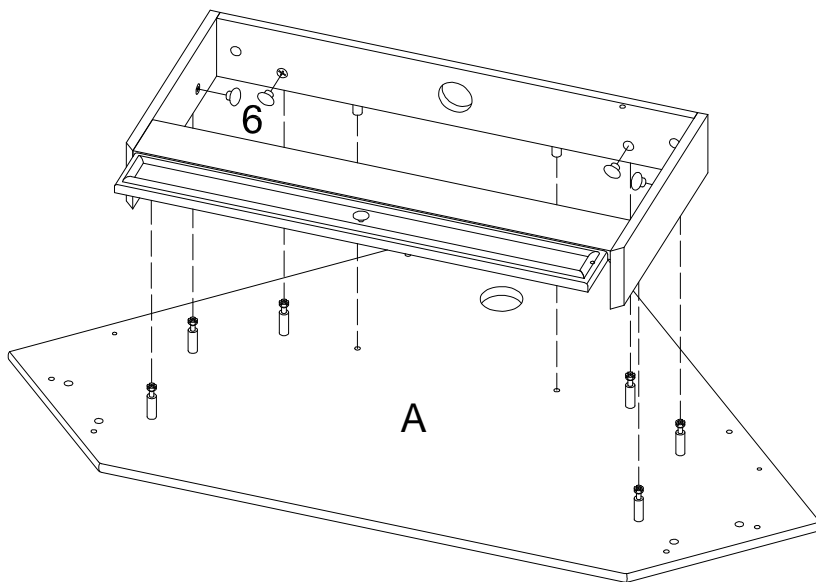

Figure 6

Attach assembled unit from figure 5 to wood top (A) by inserting wood dowels (2) and cam bolts (5) into corresponding holes until assembled unit from figure 5 and wood top (A) meet.

Tighten by rotating cam locks (4) clockwise with Phillips screwdriver.

Cover cam lock holes with covers (6).

You might find it easier to insert the wood dowels (2) into the corresponding holes on wood top (A) before attaching the assembled unit from figure 5.

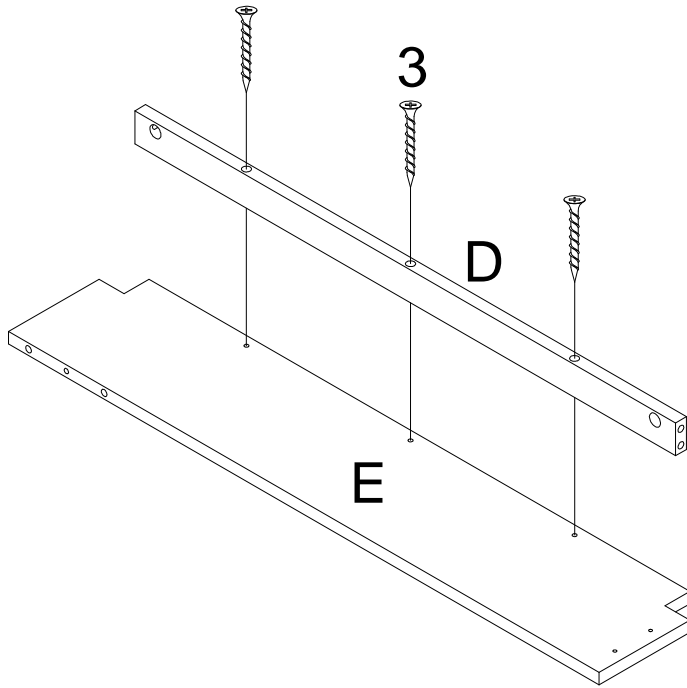

Figure 7

Insert screws (3) into bottom stretcher (D). Attach bottom stretcher (D) to left long shelf (E) by inserting screws (3) into predrilled holes on left long shelf (E).

Tighten screws (3) with Phillips screwdriver.

Make sure to insert the screws through the big hole on bottom stretcher (D) rather than the small hole.

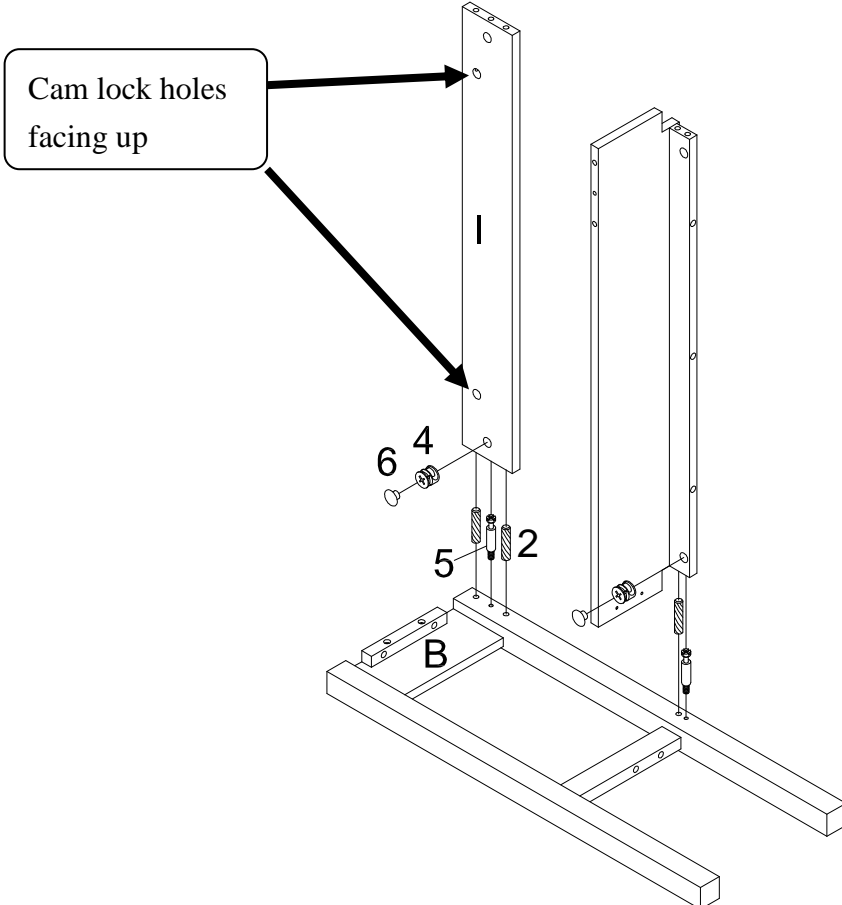

Figure 8

Insert cam locks (4) into corresponding holes on back panel (I) and assembled unit from figure 7. Screw cam bolts (5) into holes on left side leg (B).

Attach back panel (I) and assembled unit from figure 7 to left side leg (B) by inserting wood dowels (2) and cam bolts (5) into corresponding holes until assembled unit from figure 4 and back panel (I) and left side leg (B) meet.

Make sure back panel (9) has the cam lock holes facing upward.

Tighten by rotating cam locks (4) clockwise with Phillips screwdriver.

Cover cam lock holes with covers (6).

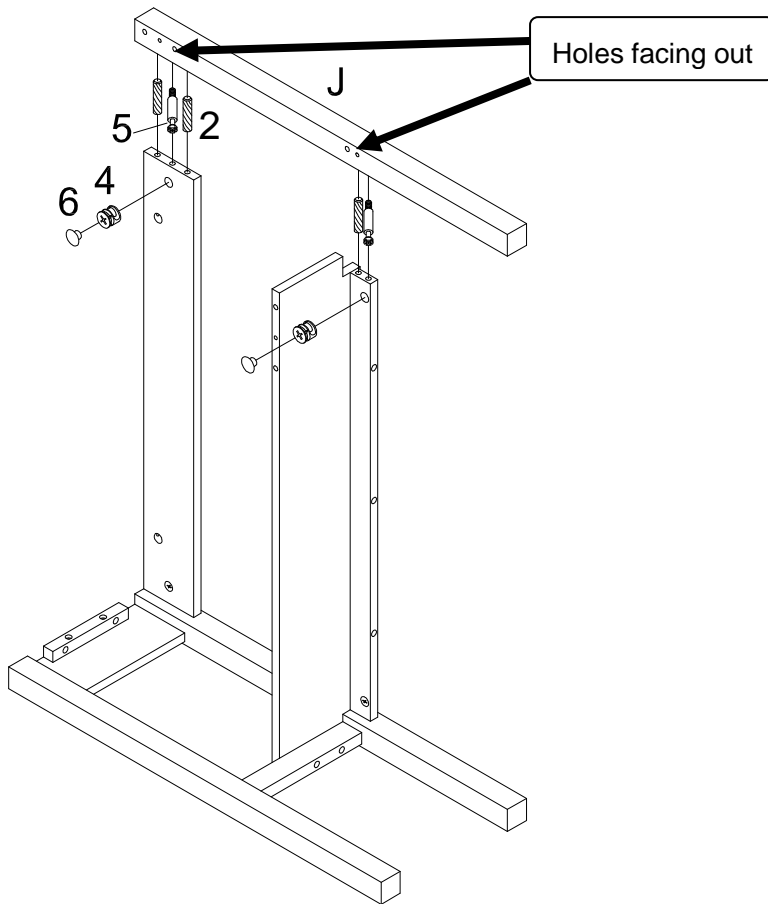

Figure 9

Insert cam locks (4) into holes on assembled unit from figure 8. Screw cam bolts (5) into holes on back leg (J).

Attach back leg (J) to assembled unit from figure 8 by inserting wood dowels (2) and cam bolts (5) into corresponding holes until assembled unit from figure 8 and back leg (J) meet.

Tighten by rotating cam locks (4) clockwise with Phillips screwdriver.

Cover cam lock holes with covers (6).

Make sure the additional cam lock and wood dowel holes are facing outwards as shown in the illustration.

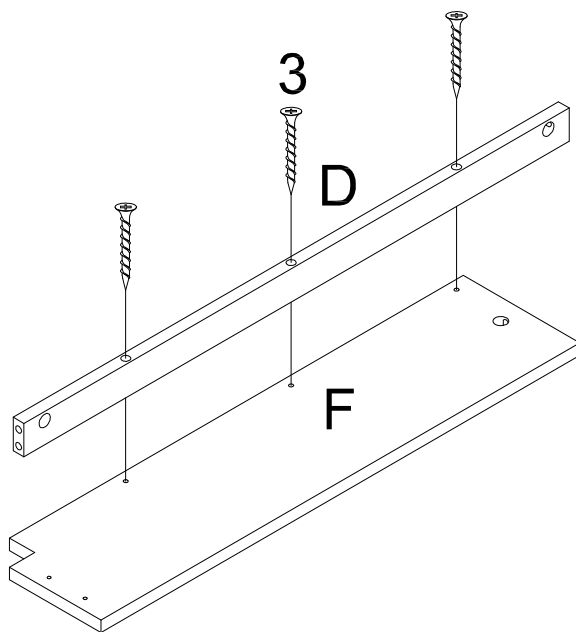

Figure 10

Insert screws (3) through bottom stretcher (D) and into the predrilled holes on right short shelf (F).

Tighten screws (3) with Phillips screwdriver.

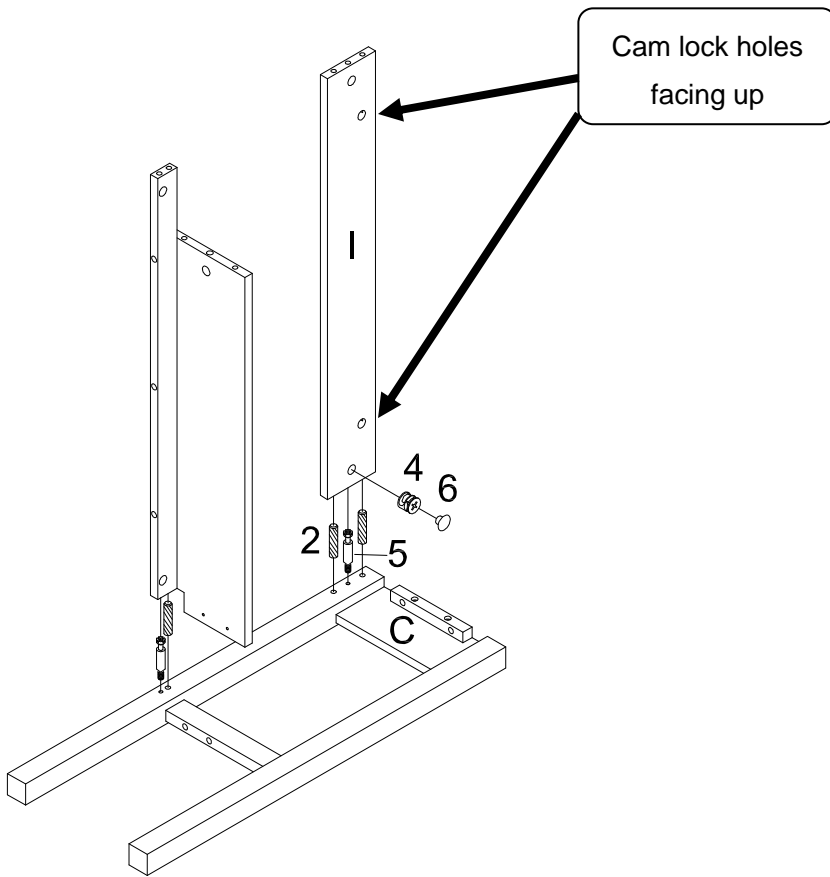

Figure 11

Insert cam locks (4) into holes on back panel (I) and assembled unit from figure 10. Screw cam bolts (5) into holes on right side leg (C).

Attach back panel (I) and assembled unit from figure 10 to right side leg (C) by inserting wood dowels (2) and cam bolts (5) into corresponding holes until assembled unit from figure 7 and back panel (I) and right side leg (C) meet.

Tighten by rotating cam locks (4) clockwise with Phillips screwdriver.

Cover cam lock holes with covers (6).

Make sure the cam lock holes on back panel (I) are facing upwards as shown.

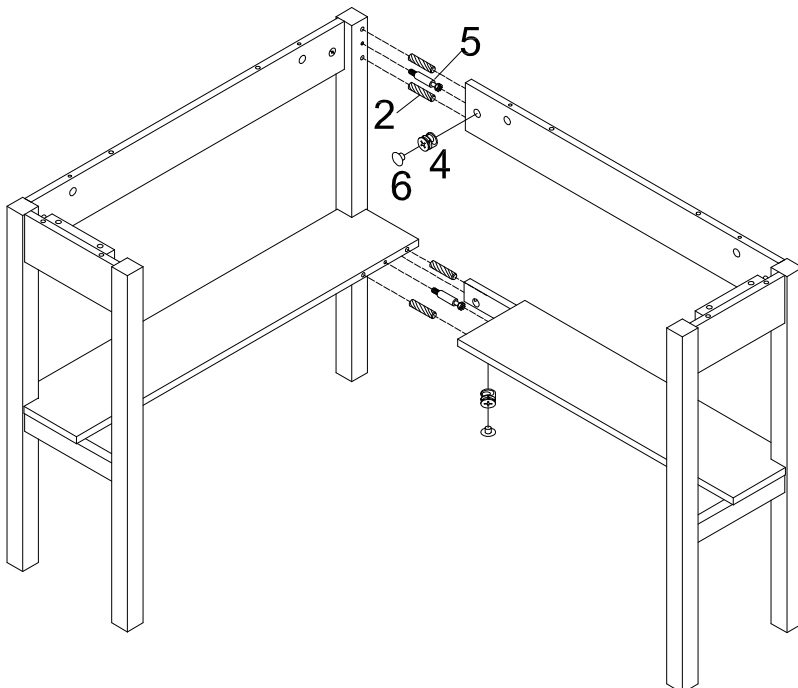

Figure 12

Insert cam locks (4) into holes on assembled unit from figure 11. Screw cam bolts (5) into holes on assembled unit from figure 9.

Attach assembled unit from figure 11 to assembled unit from figure 9 by inserting wood dowels (2) and cam bolts (5) into corresponding holes until assembled unit from figure 11 and assembled unit from figure 9 meet.

Tighten by rotating cam locks (4) clockwise with Phillips screwdriver.

Cover cam lock holes with covers (6).

This step may be easier with the help of another person.

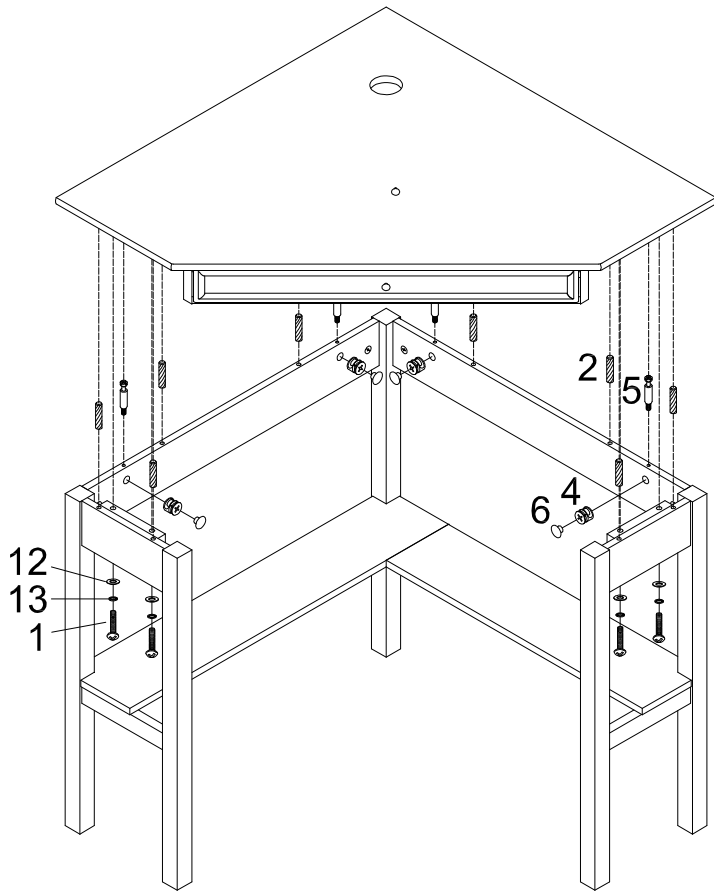

Figure 13

Insert cam locks (4) into holes on assembled unit from figure 12. Screw cam bolts (5) into holes on the bottom of wood top (A).

Attach wood top (A) to assembled unit from figure 12 by inserting wood dowels (2) and cam bolts (5) into corresponding holes until assembled unit from figure 12 and wood top (A) meet.

Insert bolts (1) through lock washers (13) and flat washers (12) to connect assembled unit from figure 12 and wood top together.

Tighten by rotating cam locks (4) and bolts (1) clockwise with Phillips screwdriver.

Cover cam lock holes with covers (6).

This step is easier with the help of another person.

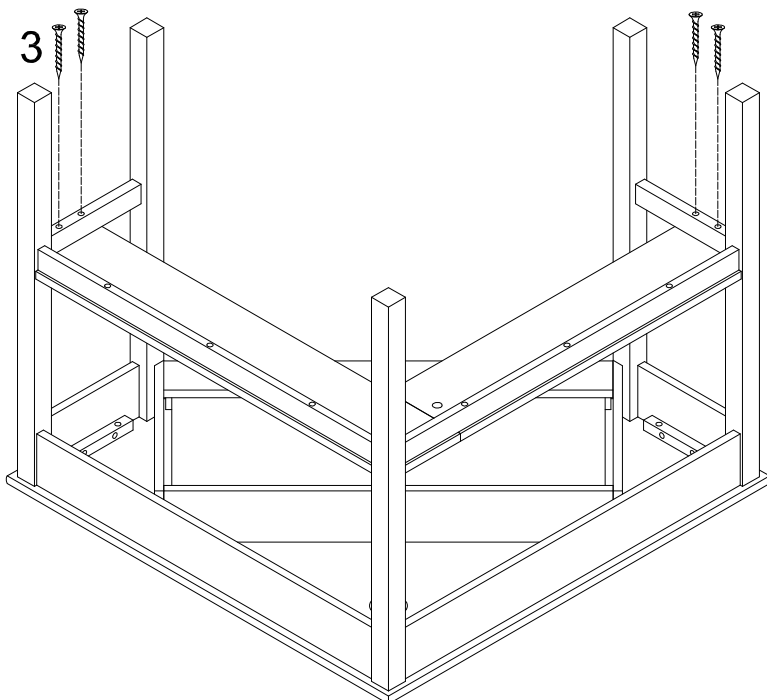
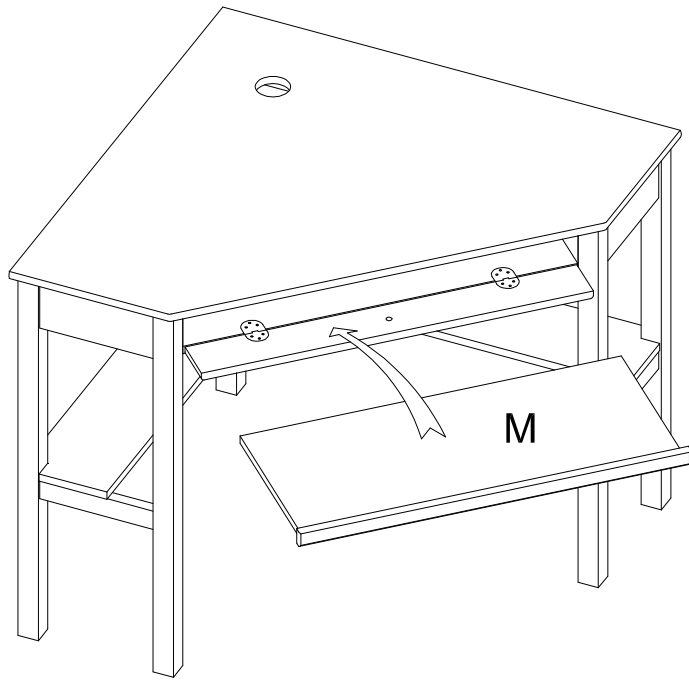

Figure 14

Turn the table upside down.

Insert screws (3) into holes on assembled unit from figure 13 as shown.

Tighten screws (3) with Phillips screwdriver.



Turn the table over and slide drawer shelf (M) into the slides of unit as shown.

Figure 15

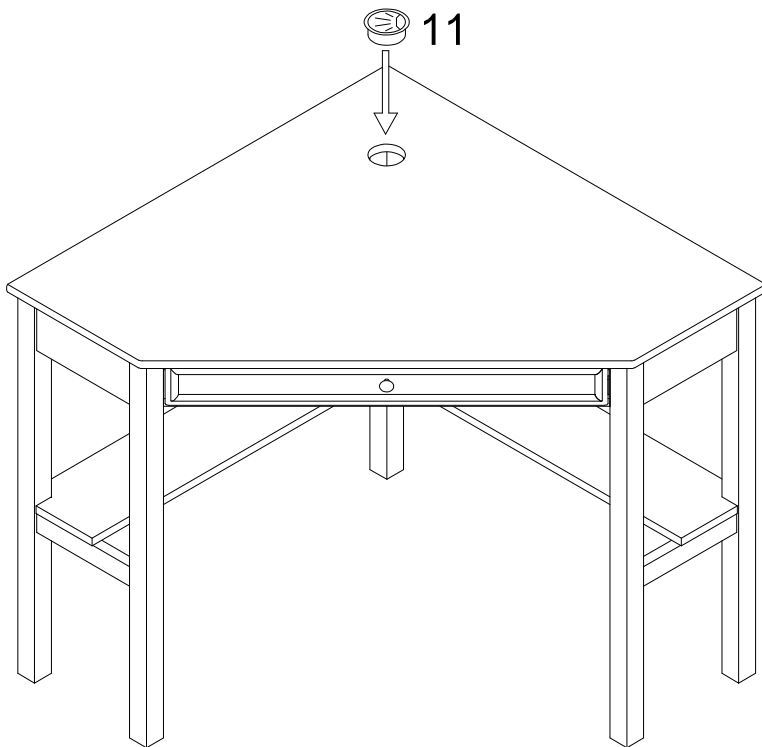

Insert plastic cap (11) into the hole on the wood top (A) as shown.

Now your new corner desk is ready to use!

Figure 16

Parts Replacement Form

Customer Information

Name _____

Address _____

City/State/Zip Code _____

Phone Number _____

Please indicate where you purchased this item: Store/Website/Catalog

Please indicate color/size/style number:

Style No	Parts Letter	Parts Description	Quantity Needed
_____	_____	_____	_____
_____	_____	_____	_____
_____	_____	_____	_____

Please immediately examine this product carefully. Any request for missing parts or damage replacement must be received within 90 days of your receipt of the product. Replacement, if available, will be honored within this time frame. Parts will not be available for items arriving fully assembled. We do not recommend modifying product(s) and we are not responsible for any damages due to product modification(s). If damages or missing parts are not reported within 90 days of your receipt, we are under no obligation to provide parts or replacement merchandise.

Please contact Southern Enterprises at 800-633-5096 or in Dallas 972-869-0111/ 9am – 4pm Mon-Fri Central time if you have product issues or email us at service@seidal.com. Please ask for customer service representative for issues involving damages or replacement parts. Please ask for technical assistance representative for any issues with product and assembly/construction.

Please contact the retailer that you purchased from for returns.



Southern
ENTERPRISES

Customer Service 1-800-633-5096

service@seidal.com

Southern Enterprises, Inc.

600 Freeport Parkway, Suite 200

Coppell, Texas 75019