



Sponge Vase

The quality of porcelain is best reflected through its fine and delicate properties, a quality that is not celebrated when using a mould. Marcel Wanders has developed a technique to produce porcelain objects without the use of plaster moulds. A natural sponge is taken and dipped in a fluid porcelain clay slip. The clay impregnates the sponge. Once the sponge has dried, the sponge is fired within a Kiln. The sponge is burnt away and the perfect porcelain replica of the sponge remains. An intelligent manufacturing process that has the ability to show the intricate qualities of porcelain clay.

| | |
|---------------------------------|---|
| <i>Designer</i> | Marcel Wanders |
| <i>Year of design</i> | 1997 |
| <i>Material</i> | Porcelain |
| <i>Additional Product Codes</i> | This product was developed in a project with Droog Design and Rosenthal Moooi, accessories, sponge vase, MOASV----- |

Detailing



The delicate intricacy of the Natural sponge structure covers the surface of the vase.

Colour



Unglazed Porcelain exterior.
White glazed interior.

m o o o i[®]

Main dimensions

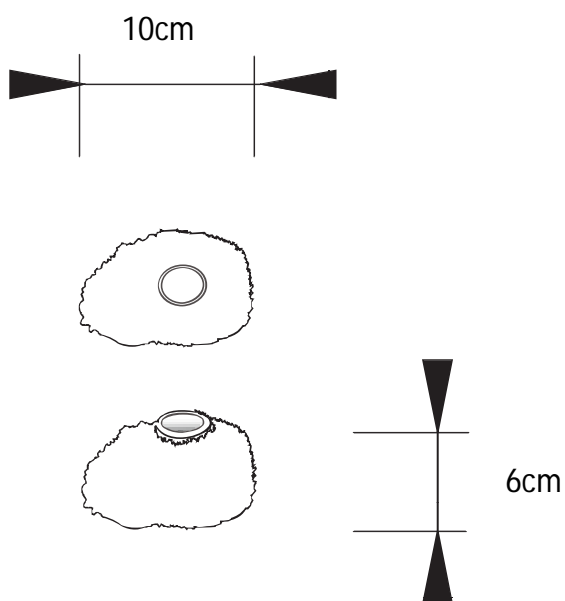

Technical

There is no technical information specific to this product.

Packaging



H-19cm
W-27cm
D-27cm



1-Colli
0.43-Net
1-Gross



The Sponge vase arrives in a gift box with no additional components.

m o o o i[®]

Photography



Credits Kasia Gatkowska

Cleaning Instructions

To clean the Sponge vase, submerge it in lukewarm water with a little diluted washing-up liquid and allow to drip-dry in a safe place.
