

Flushmount Canopy Installation Instructions

We thank you for selecting one of our superior quality products. We dedicate considerable time and effort to ensure they are the best available.

GENERAL

*To assure success of this installation be sure to read the instructions and review the diagrams thoroughly before beginning. Follow the instructions that are applicable for you.

***NOTE:** The important safeguards and instructions appearing in this manual are not meant to cover all possible conditions and situations that may occur. It must be understood that common sense, caution and care are factors that cannot be built into any product. These factors must be supplied by the person(s) caring for and operating the unit.

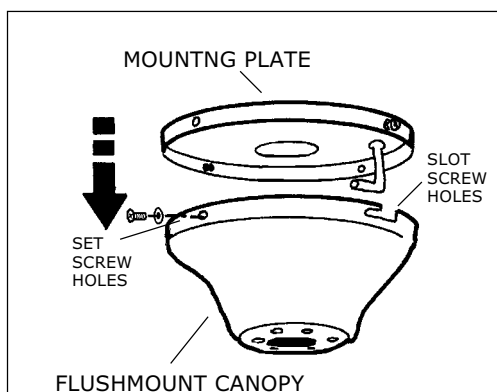

Disassemble the flushmount canopy from the mounting plate by unscrewing the two screws in the set screw holes and loosening the screws in the slot screw holes. Twist the canopy counter-clockwise and pull apart the two pieces.

1

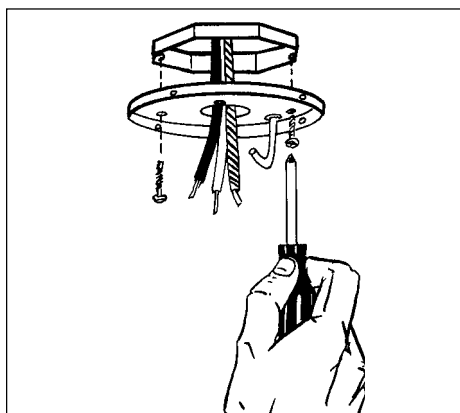

Install mounting plate to outlet box in ceiling using the screws provided with the outlet box.

2

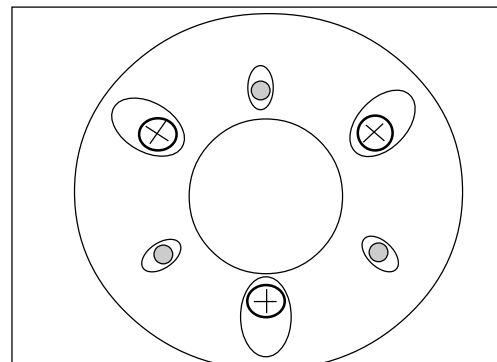

The large holes in the canopy are to be placed over the existing screws. The smaller holes should line up with the holes in the top of the motor housing. Your fan may come with six screws installed in the top of the housing. If that is the case then you will need to remove every other screw and then install the canopy..

3

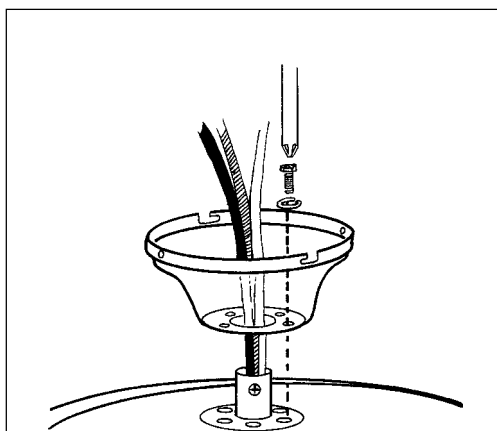

Attach canopy directly to top of motor housing. Secure the canopy with the flushmount screws and lock washers provided. **WARNING: Make sure to use washers on each screw as provided and tighten securely.**

4

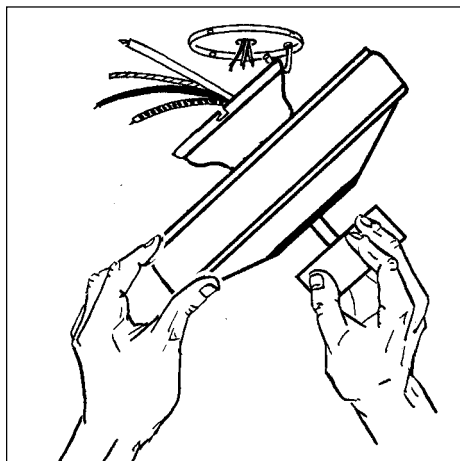

Carefully hang fan onto hook in mounting plate using one of the two holes in the canopy. This will allow hands-free wiring. Follow wiring instructions supplied with fan.

5

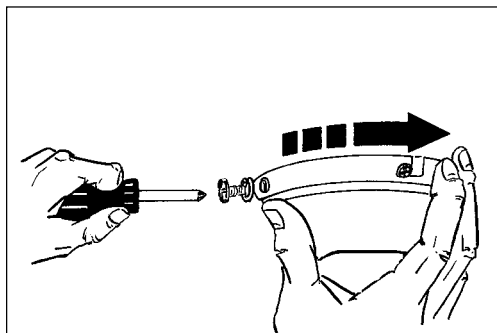

Rotate canopy clockwise until both mounting screws drop into slot recesses. Tighten screws securely. Install third and fourth screws with lockwashers into mating holes and tighten.

6

sea gull lighting®