



# LINON HOME DÉCOR PRODUCTS INC.

## ASSEMBLY INSTRUCTIONS

**MODEL: 0217VESP-01-KD-U**

### **24" MONACO COUNTER STOOL**

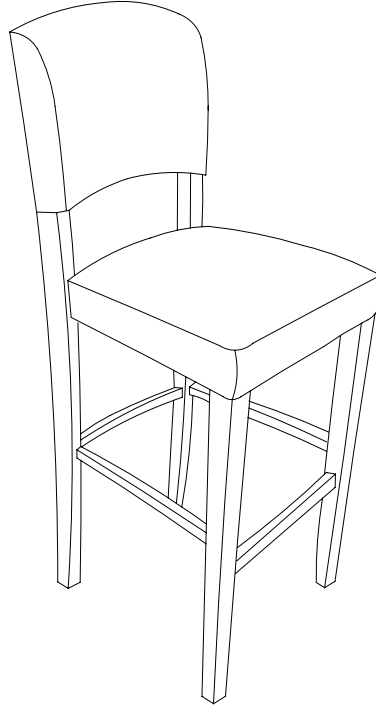

#### **We are here to help!**

We do our best to insure that your furniture arrives in excellent condition. In the event that a part is damaged or missing, Linon Home Decor will be happy to provide you with replacement parts, at no charge, within 30 days of purchase, providing the parts are available in our warehouse and the item purchased are part of our current inventory. **In order to receive spare parts, at no charge, you must provide proof of purchase within 30 days.**

If you need assistance with assembly or replacement parts, please call Linon Customer Service, prior to returning the item to the store.

Our office is open Monday – Friday 9AM – 5PM, Eastern Standard Time.

Our Toll free customer service number is: 1-800-262-1852.

Or visit our web site [www.Linon.com](http://www.Linon.com) to order spare parts and for care instructions on you're newly purchased furniture.



# LINON HOME DÉCOR PRODUCTS INC.

## ASSEMBLY INSTRUCTIONS

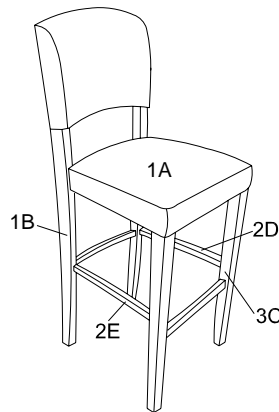

## PARTS LIST

PARTS	GRAPHICS	DESCRIPTION	QUANTITY
1A		SEAT ASSEMBLY	1
1B		BACK ASSEMBLY	1
3C		FRONT LEG ASSEMBLY	1
2D		RIGHT SIDE STRETCHER	1
2E		LEFT SIDE STRETCHER	1
F		SHORT BOLT	2
G		BACK LEG BOLT	4
H		FRONT LEG BOLT	4
I		SPRING WASHER	10
J		FLAT WASHER	10
K		ALLEN HEXAGONAL WRENCH	1
L		WOOD SCREW	4
M		ADHESIVE PADS	4

If any parts are missing or damaged in this package Home Decor will be happy to provide you with replacement parts, at no charge, within 30 days of purchase, providing the parts are available in our warehouse and the item purchased is part of our current inventory. **In order to receive spare parts, at no charge, you must provide proof of purchase within 30 days.**

Call us toll free at 1-800-262-1852. Or visit our web site [www.Linon.com](http://www.Linon.com) to order spare parts and for care instructions on you're newly purchased furniture.



### **PREPARATION:**

SELECT A WORK SURFACE. WE RECOMMEND A TABLE TOP. PLEASE PROTECT IT VERY WELL, INCLUDING THE EDGES TO PREVENT ANY DAMAGES; YOU MAY USE A BLANKET AND THE CARDBOARD FROM THE STOOL BOX.

YOU WILL NEED TO USE YOUR OWN PHILLIPS SCREWDRIVER WITH #2 SIZE HEAD.

### **STEP-1: CONNECT SEAT-1A TO BACK-1B AS SHOWN IN FIGURE-1**

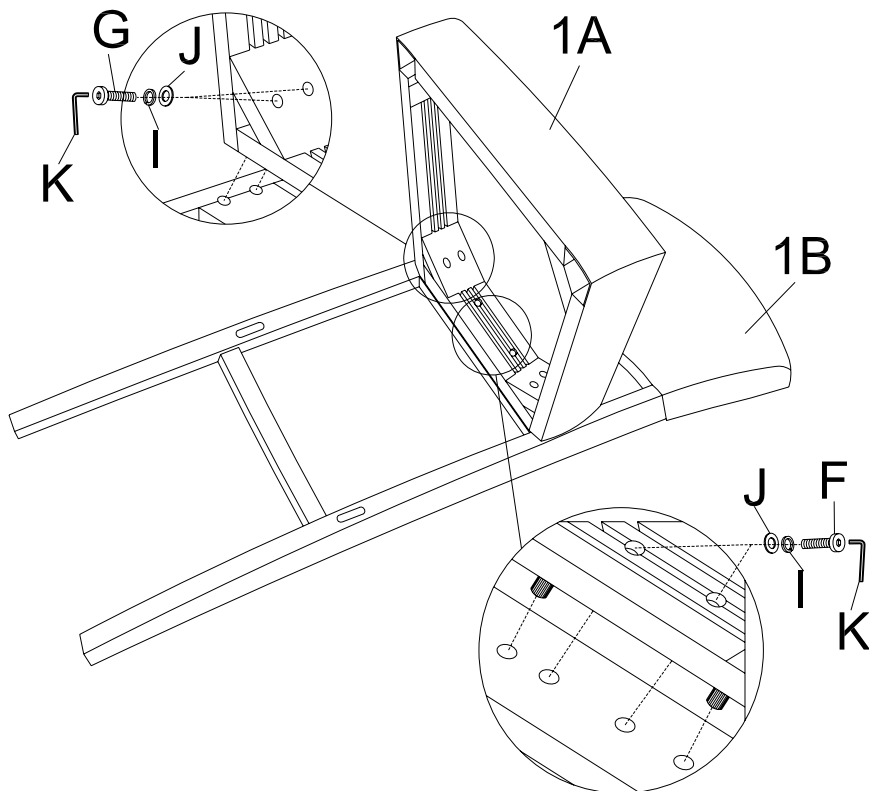
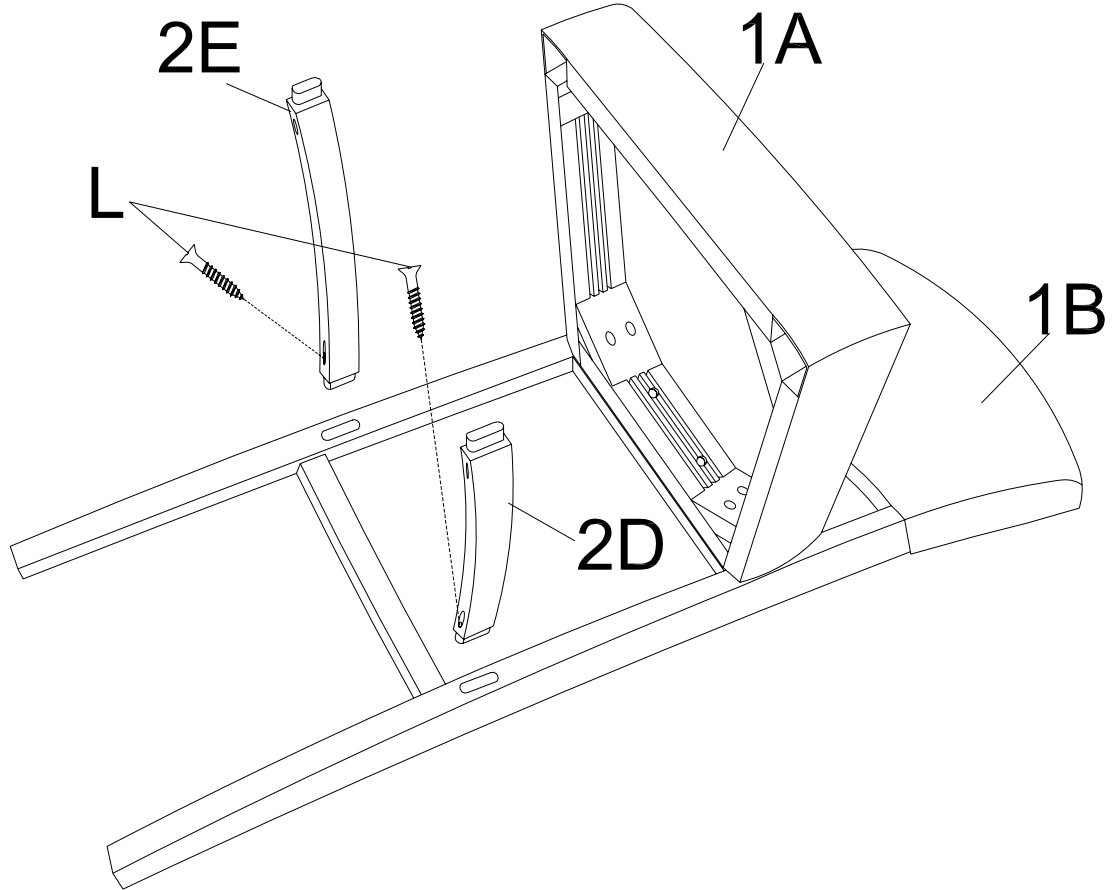

**FIGURE-1**

- 1.1 POSITION BACK-1B ON THE WORK SURFACE AS SHOWN IN FIGURE-1.
- 1.2 LOOK FOR TWO WOODEN DOWELS OUTSIDE SEAT-1A; INSERT THEM INTO THE CORRESPONDING HOLES IN THE RAIL OF BACK-1B.
- 1.3 INSERT ONE SPRING WASHER-J, THEN ONE FLAT WASHER-I OVER ONE BACK LEG BOLT-G; INSERT THE BOLT-G THROUGH ANY OF THE FOUR HOLES IN THE CORNER BRACKETS ADJACENT TO THE BACK LEGS; IF NECESSARY, MOVE THE BOLT-G AROUND TO FIND THE HOLE IN THE BACK LEG. TIGHTEN BY HAND.
- 1.4 REPEAT PROCEDURE 1.3 TO INSTALL THE REMAINING THREE SETS G+J+I.
- 1.5 REPEAT PROCEDURE 1.4 TO INSTALL TWO SHORT BOLTS WITH HARDWARE F+J+I TO SECURE SEAT-1A TO BACK-1B.



### STEP-2 : CONNECT THE SIDE STRETCHER TO THE BACK-1B AS SHOWN IN FIGURE-2

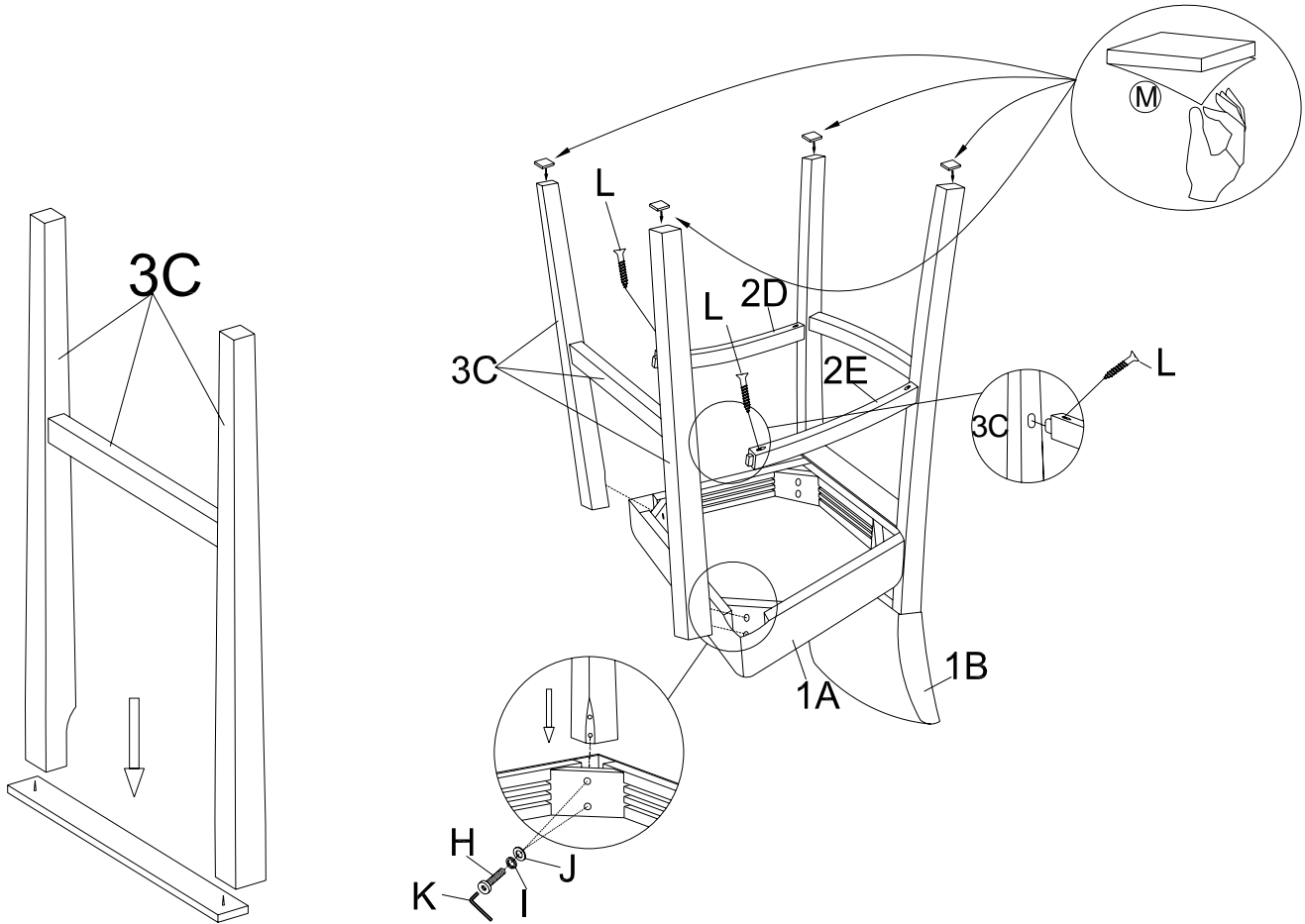

**FIGURE-2**

- 2.1 FOLLOW THE LABELS ON STRETCHERS 2D AND 2E INSERT THEM IN THE BACK LEGS AS SHOWN. SECURE CONNECTION WITH TWO WOOD SCREWS-L.



### **STEP-3 : CONNECT THE FRONT LEG TO SEAT-1A AND SIDE STRETCHER AS SHOWN IN FIGURE-3**



**FIGURE-3A**

**FIGURE-3B**

- 3.1 REMOVE THE SHIPPING CLEAT FROM END OF FRONT LEG ASSEMBLY-3C.
- 3.2 TURN CHAIR AROUND WITH SEAT IN THE WORK SURFACE AS SHOWN IN FIGURE-3B.
- 3.3 CONNECT FRONT ASSEMBLY-3C TO STRETCHERS 2D AND 2E USING TWO WOOD SCREWS-G, THEN CONNECT IT TO SEAT-1A USING FOUR FRONT LEG BOLTS-H WITH FOUR SPRING WASHERS-I, AND FOUR FLAT WASHERS-J AS SHOWN IN FIGURE-3B.
- 3.4 PLACE FOUR FOOT PAD-M TO THE LEGS OF THE STOOL AS SHOWN.



### **MAINTENANCE:**

- 4.1 YOUR STOOL ASSEMBLY IS NOW COMPLETED. ENJOY USING IT !
- 4.2 DO NOT DISCARD THE ALLEN HEXAGONAL WRENCH-D; KEEP IT FOR FUTURE USE.
- 4.3 PERIODICALLY CHECK ALL CONNECTIONS AND RE-TIGHTEN BOLTS AND WOOD SCREWS IF NECESSARY. DO NOT OVER-TIGHTEN TO AVOID STRIPPING WOOD OR METAL NUTS.
- 4.4 CLEAN THE LACQUER FINISH IF NECESSARY WITH CLEAN WATER DAMP CLOTH. IF YOU DO NOT MIND A CHANGE OF LACQUER SHEEN THEN YOU MAY USE A NON-ABRASIVE FURNITURE CLEANER. DO NOT USE HOUSEHOLD CLEANING CHEMICALS.
- 4.5 CLEAN THE UPHOLSTERY WITH A WATER DAMP CLOTH. DO NOT USE HOUSEHOLD CHEMICALS.



**LINON LIMITED MANUFACTURER'S**

**WARRANTY**

This product is covered under our manufacturer's limited warranty (Linon Home Décor Products). This ensures that under this warranty the Linon item:

Replacement of missing or initially defective parts will be sent, at no charge, for a period of 30 days from the date of purchase with valid proof of purchase providing the parts are available in our warehouse and the item purchased is part of our current inventory.

The warranty does not cover any labor and or freight charges to or from the service center. It does not cover furniture used for commercial purposes, failures caused by improper care, unreasonable or abusive use, freeze damage or acts of God.

All purchase must be made in authorized dealerships during the normal course of business. Proof of purchase may be required.

**Service**

For further information please contact our customer service department between the hours of 9:00 AM and 5:00 PM Eastern Standard Time. You can contact us at:

Linon Home Décor Products  
22 Jericho Turnpike  
Mineola, NY 11501

E-Mail: [consumersupport@Linon.com](mailto:consumersupport@Linon.com)

Toll Free: 1-800-262-1852

Visit our web site [www.Linon.com](http://www.Linon.com) to order spare parts and for care instructions on your newly purchased furniture.