











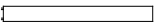

Notice: Please review the parts listing and check for all parts before assembling the fixture. If any parts are missing or damaged, please note on this sheet and contact the place of purchase to arrange for replacement parts.

| PARTS LIST | | Company Name: _____ Co. Account #: _____ to be filled out by retailer | |
|---|--|--|--|
| Canopy 1ea Ø1-1/2"*H5mm  | Nipple 1ea 1/8-IP*H45mm  | ROD 1ea 1/8-IP*H122mm  | |
| Finial 1ea Ø1-1/4"*H49mm  | Wire connectors 3ea P3 Orange  | Mounting Screws 2ea 8#32-IP*1-1/2"  | |
| Mounting Strap 1ea Ø4"*H10mm  | Mounting Screws 2ea 8#32-IP*1"  | Hex Nut 2ea 5/32-IP*H3mm  | |
| Wire connectors 3ea P3 Orange  | Nipple 1ea Ø1"*H3mm  | Flat washer 1ea Ø1-1/2"*H2mm  | |
| Hex Nut 1ea 1/8-IP*H4mm  | Rubber Washer 1ea Ø1-1/2"*H2mm  | | |
| Part Needed _____ | Quantity _____ | | |
| Part Needed _____ | Quantity _____ | | |
| Reason why (missing, scratched, broken glass, bent, bad finish) | | | |
| Comments _____ | | | |

FIXTURE ASSEMBLY INSTRUCTIONS

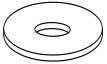
Read and review installation instruction sheet before assembling the fixture.

1. Thread the Nipple (K) into the fixture pan coupling (J).
2. Install the light bulbs in accordance with the fixture's specifications.
3. Thread Nipple (S) into Rod (K). Slide Flat Washer (R) and Glass (L) onto Nipple (S). Then put Cap (T), Rubber Washer (M), and Flat washer (N) onto Nipple (S).
4. Thread Hex Nut (O) onto Nipple (S) to secure.
5. Slide Canopy (P) onto Nipple (S). Secure with Finial (Q).

DO NOT EXCEED MAXIMUM WATTAGE RATING!

NOTE: INSTALL THE GLASS ASSEMBLY AFTER THE FIXTURE IS HUNG.

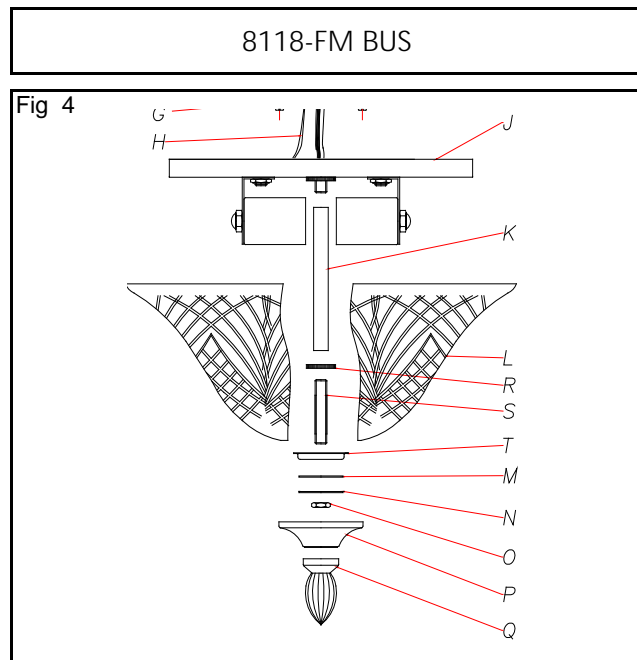

For Customer Service, contact the place of purchase to arrange for replacement parts.

WARNING ! SHUT OFF POWER AT FUSE OR CIRCUIT BREAKER.

HANGING THE FIXTURE (Fig.1)

1. Carefully remove the new fixture from the carton and the yellow bag that holds all your parts. Check that all parts are included as shown in the illustration and parts list.
2. Shut off power at the circuit breaker and remove the old fixture from ceiling, including the old mounting strap.
3. Thread the two Fixture Mounting Screws (G) into the pre-drilled Holes in the Mounting Strap (E) spaced the same distance apart as the holes in the ceiling pan. Secure in place with Hex nuts (F).
4. Attach Mounting Strap (E) to the junction box using the two Mounting Screws (D)

CONNECTING THE WIRES (Fig 2)

5. Attach the power supply wires to the fixture lead wires by connecting BLACK to BLACK (or SMOOTH) and WHITE to WHITE (or RIBBED).
 6. Attach the GROUND wire (GREEN or COPPER) from the Junction Box and the fixture Ground wire to the green Ground Screw (L) on the Mounting Bracket (E) or connect both wires together using a wire connector.
- NOTE: Twist the wires together in the same direction you twist the wire connector onto the wires.
7. Tuck these wire connections neatly into the Junction Box.

FINISHING THE INSTALLATION

8. Finish mounting the Ceiling Pan (J) by placing it over the Mounting Strap (E) as shown in Fig. 1. Rotate the pan until the Mounting Screws (G) protrude through the "Keyholes" located in the bottom of Ceiling Pan (J). Using a screwdriver, secure the Ceiling Pan (D) by screwing Mounting Screws (G) until tight.
9. Install the light bulbs in accordance to the fixture's specifications.
10. Install the glass shade according to the assembly instructions.

YOUR INSTALLATION IS NOW COMPLETE. RETURN POWER TO THE JUNCTION BOX AND TEST THE FIXTURE.

