



H-A.6029 01 00-3

calligaris



**Calligaris s.p.a.**  
Via Trieste, 12  
33044 Manzano  
(Udine) Italy  
Tel. +39 0432 748211  
Fax +39 0432 750104  
[www.calligaris.it](http://www.calligaris.it)

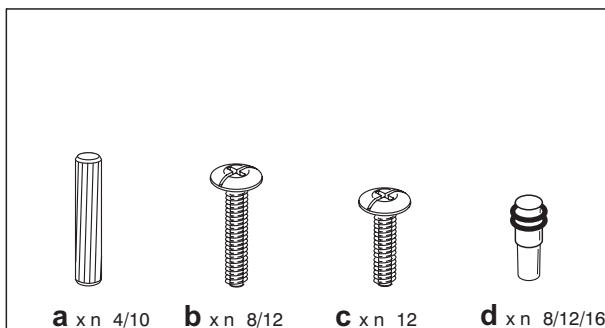

- I Prima di iniziare il montaggio identificare tutti i componenti con l'aiuto delle istruzioni.
- GB Before starting to assembly, please identify all components.
- D Vor der Montage sind die Einzelteile anhand der Montageanleitung zu identifizieren.
- F Avant de débiter le montage identifiez tous les composants à l'aide de la notice.
- E Antes de iniciar el montaje, identifique todos los componentes con ayuda de la nota.

CS/6029-0-1-2-4-6-7

CS/6029-0		F-6029 G
CS/6029-1		F-6029 A
CS/6029-1A		F-6029 E
CS/6029-2		F-6029
CS/6029-4		F-6029 B
CS/6029-6		F-6029 A
CS/6029-7		F-6029

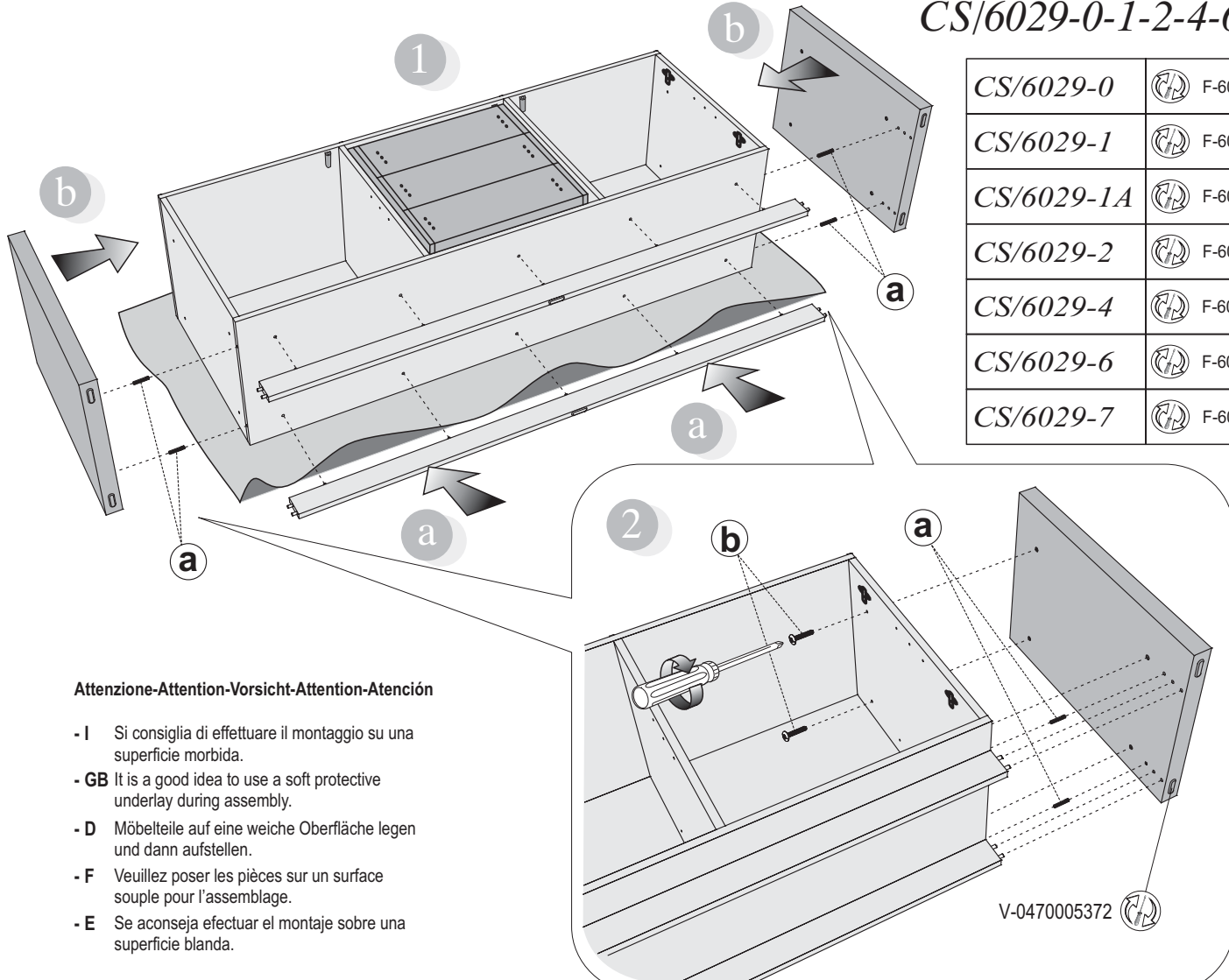

Attenzione-Attention-Vorsicht-Attention-Atención

- I Si consiglia di effettuare il montaggio su una superficie morbida.
- GB It is a good idea to use a soft protective underlay during assembly.
- D Möbelteile auf eine weiche Oberfläche legen und dann aufstellen.
- F Veuillez poser les pièces sur un surface souple pour l'assemblage.
- E Se aconseja efectuar el montaje sobre una superficie blanda.

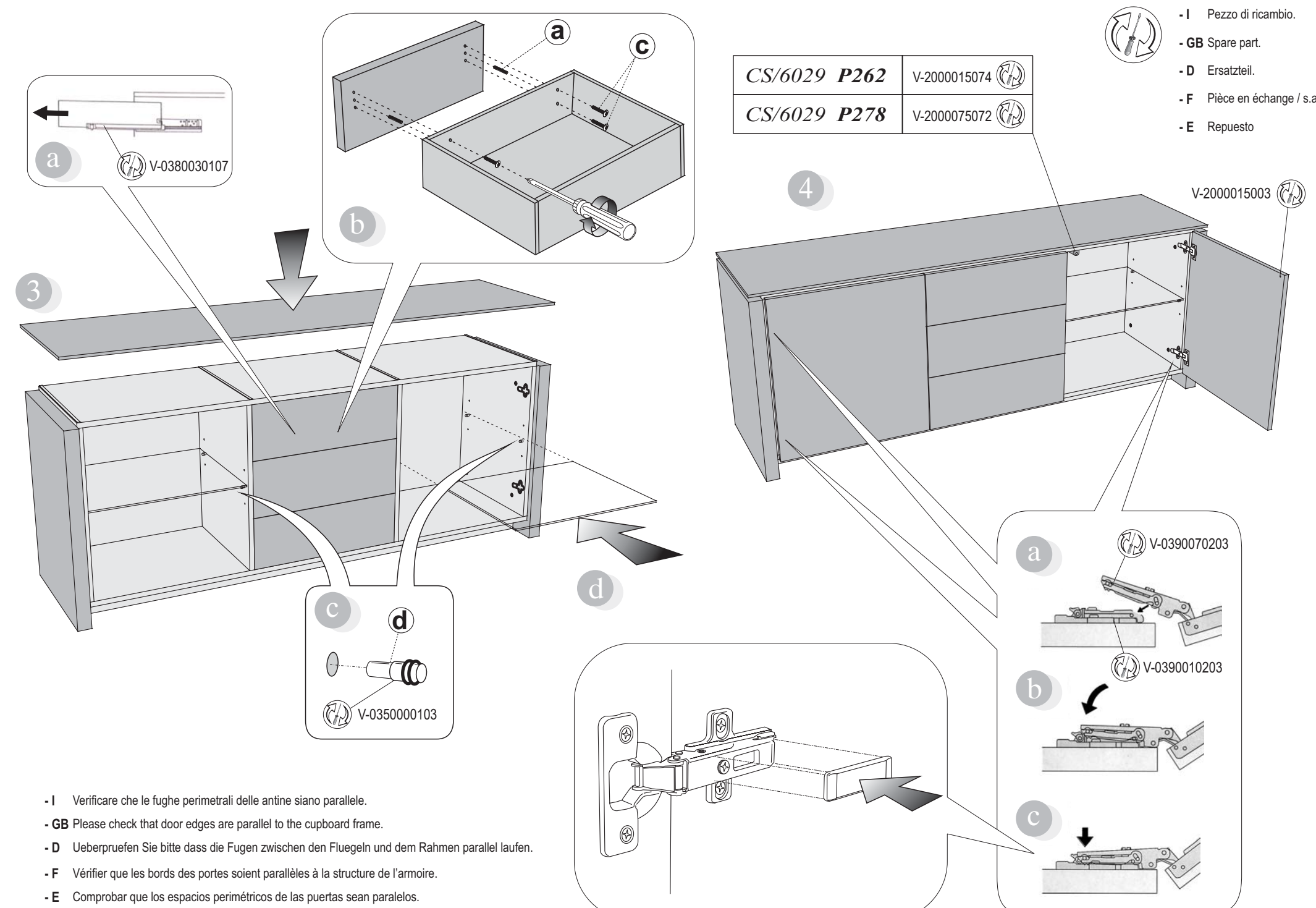

- I Verificare che le fughe perimetrali delle ante siano parallele.
- GB Please check that door edges are parallel to the cupboard frame.
- D Überprüfen Sie bitte dass die Fugen zwischen den Flügeln und dem Rahmen parallel laufen.
- F Vérifier que les bords des portes soient parallèles à la structure de l'armoire.
- E Comprobar que los espacios perimétricos de las puertas sean paralelos.

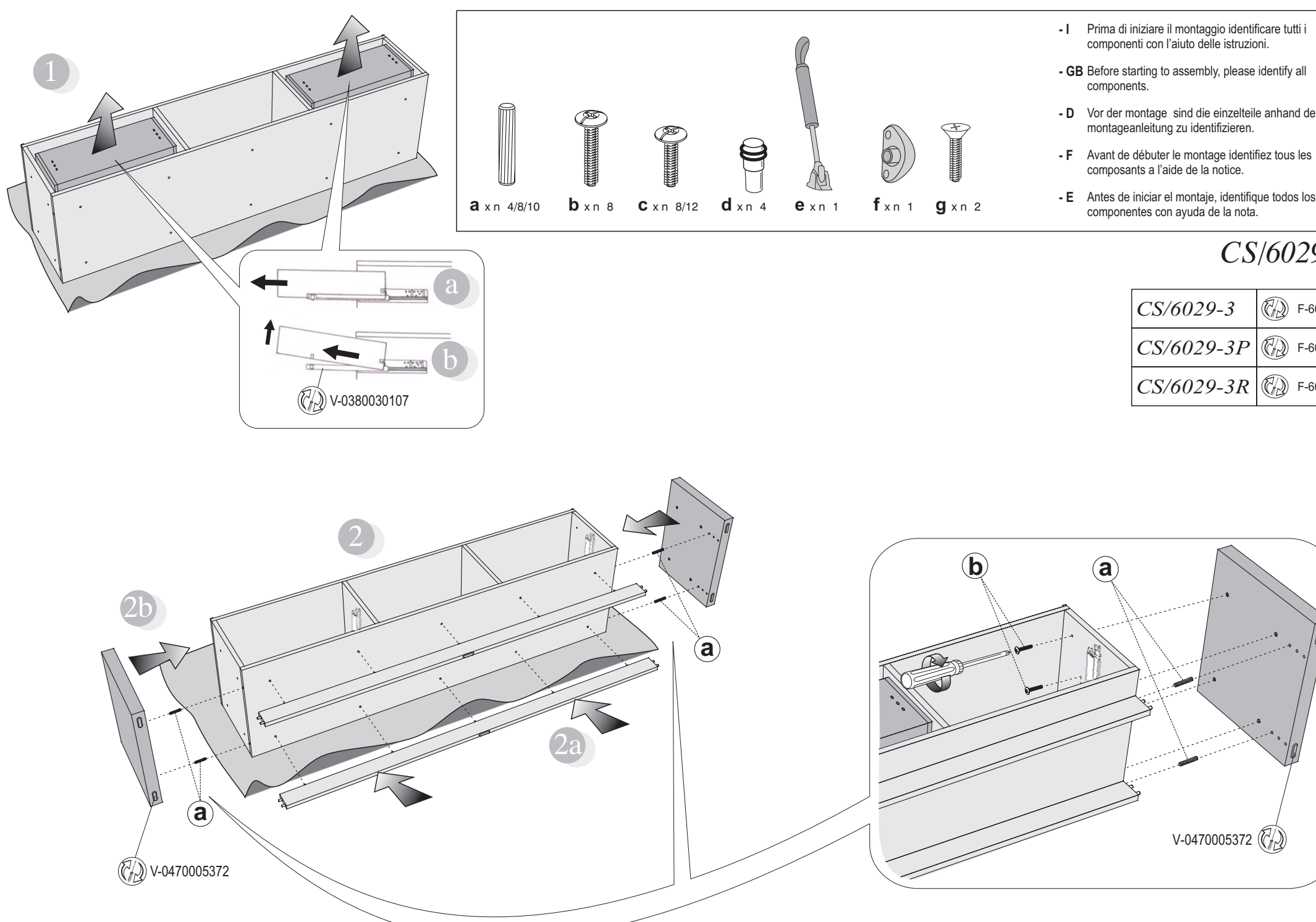

- I Prima di iniziare il montaggio identificare tutti i componenti con l'aiuto delle istruzioni.
- GB Before starting to assembly, please identify all components.
- D Vor der Montage sind die Einzelteile anhand der Montageanleitung zu identifizieren.
- F Avant de débiter le montage identifiez tous les composants à l'aide de la notice.
- E Antes de iniciar el montaje, identifique todos los componentes con ayuda de la nota.

CS/6029-3

CS/6029-3		F-6029 D
CS/6029-3P		F-6029 F
CS/6029-3R		F-6029 H

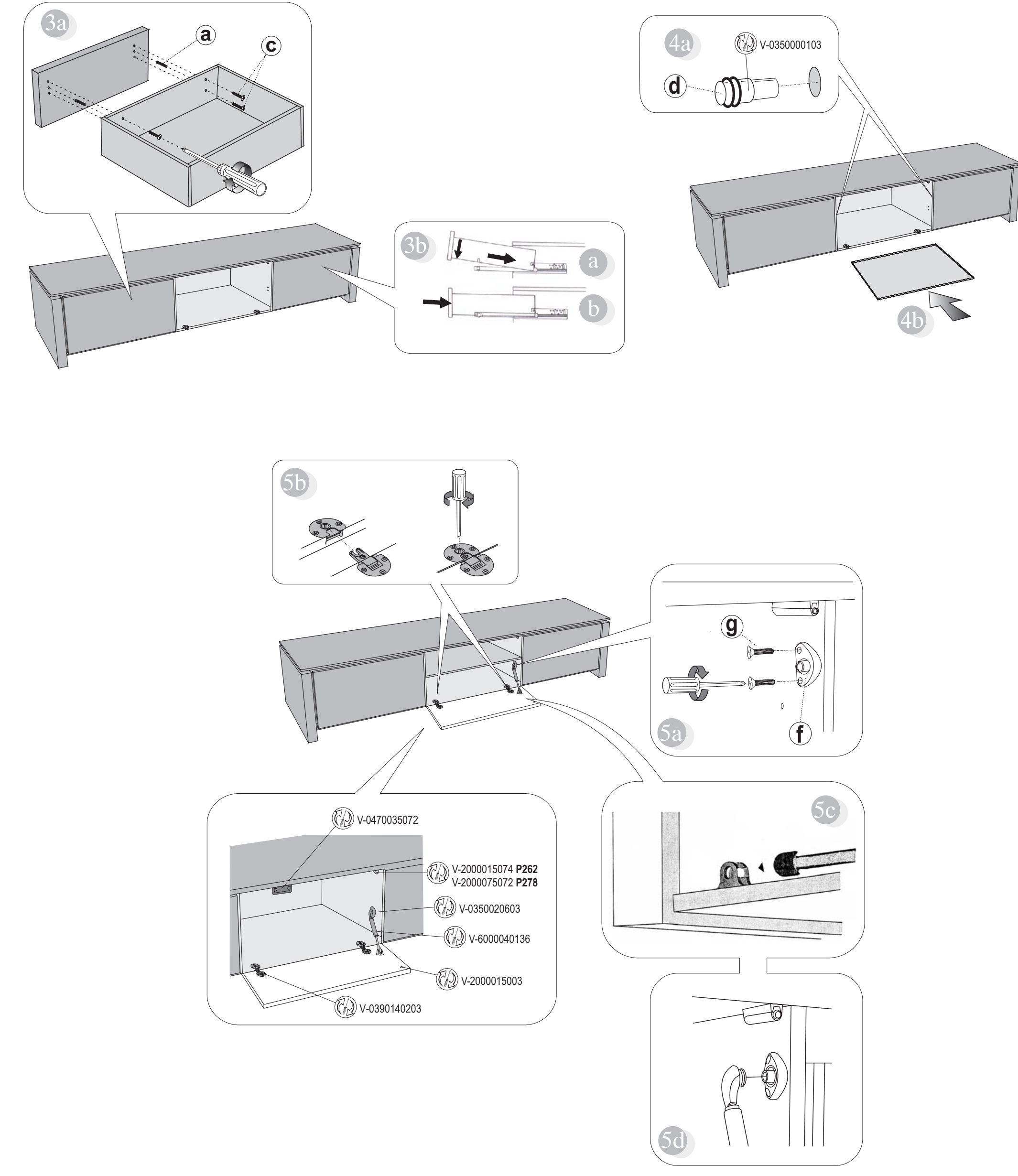

	V-047003572
	V-2000015074 P262
	V-2000075072 P278
	V-0350020603
	V-6000040136
	V-2000015003
	V-0390140203

