

Please read instructions carefully to avoid accidental damage to components during assembly.

Quality Wooden Children's Furniture and Accessories

Made in America • Established 1987

www.littlecolorado.com

Revised 5/15
C R Shaw



WARNING: ADULT ASSEMBLY REQUIRED

WARNING: Assembly kit contains parts with sharp points.

WARNING: Assembly kit contains parts with sharp edges.

WARNING: Package contains plastic bags that present suffocation risks for children.

WARNING: Assembly kit contains small parts that present choking hazards for children.

Toy Storage Chest Assembly Instructions; Stock # 58 MDF Version Only

- Please inspect the parts for damage during shipping and for any missing items. If you suspect that there may be damage or a shortage, contact us and we will send replacement parts if needed.
- As soon as components and hardware are unpacked; please remove and recycle all plastic bags from possible contact with children.
- Words in **Red** represent a component or hardware used in assembly.
- Illustrations are intended to help identify components and hardware and are not drawn to scale.

Toy Storage Chest Components

Tools needed for assembly

Hardware

- Medium size #2 Phillips Screwdriver
- Supplied Allen Wrench

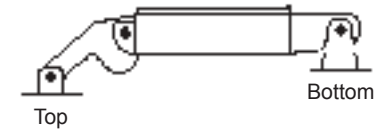

1- Lid Support

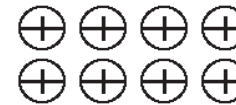
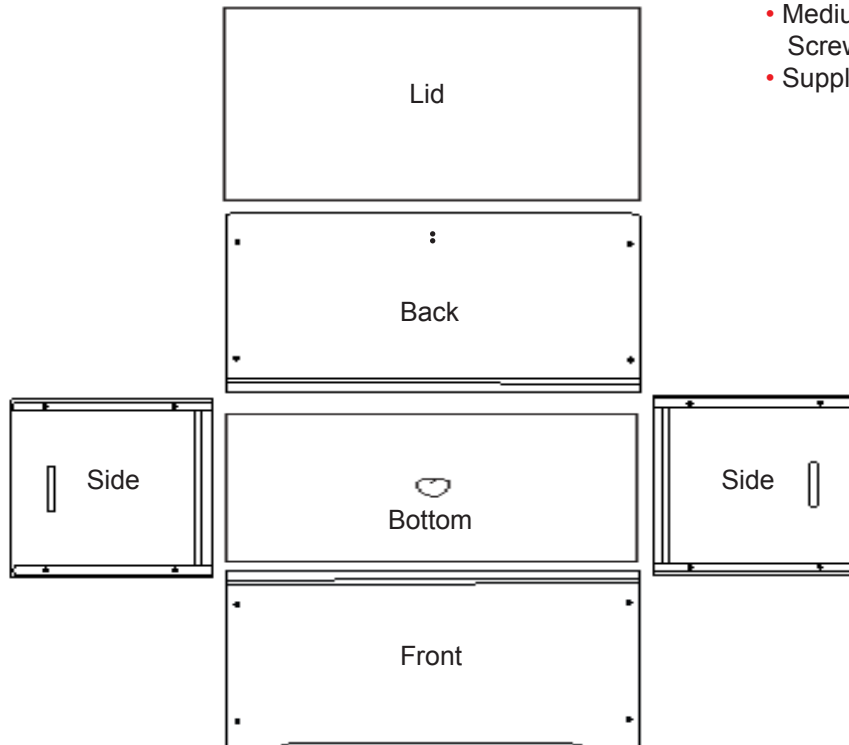

8- Barrel Nuts

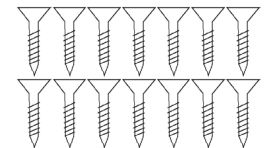

14- #5 5/8 in.
Wood Screws

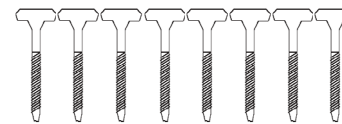

8- Joint Connector Bolts

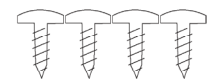

4- #8 5/8 in.
Wood Screws

Toy Storage Chest Assembly Instructions- Continued

1

- Starting with a **Side** panel, insert one **Joint Connector Bolt** in Joint Connector Bolt hole.

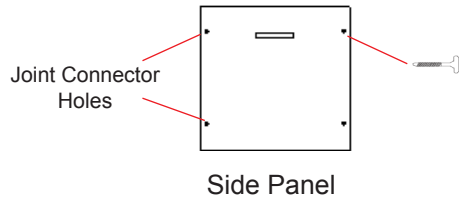

2

- Insert a **Barrel Nut** into the **Back** panel Barrel Nut hole in relation to the Joint Connector Bolt previously installed.
- Make sure the longest slot on the head of the Barrel Nut is perpendicular to the Joint Connector Bolt.

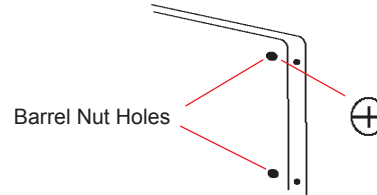

3

- Fasten the **Side** panel and **Back** panel together. Start Joint Connector Bolt by hand and after a few turns begin using the supplied Allen wrench.
- Make sure **Back** panel fits inside groove. Tighten bolt to a snug fit. Then unscrew one full turn to allow adjustment.

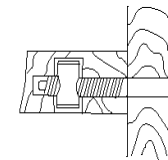

- Now, repeat steps 1,2 and 3 for second hole and to assemble the other **Side** panel.

4

- Now that you have the two sides fastened to the back; slide the **Bottom** panel in the bottom grooves (The side with the Little Colorado logo is the top side).

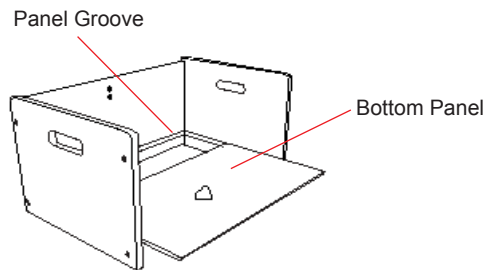

5

- Using the existing holes, attach bottom of **Lid Support** to inside of **Back** with 2 **#8** screws.
- Be careful not to over tighten screws.

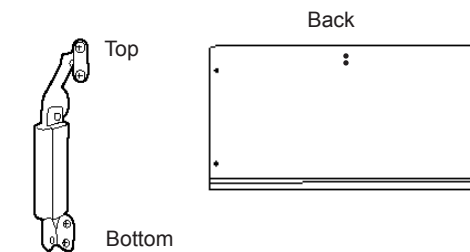

Lid Support

6

- Place **Lid** on top of the box and line up existing holes located on outside of the back panel to holes in hinge. Attach hinge to back of box using 15 **#5** screws.
- Be careful not to over tighten screws.

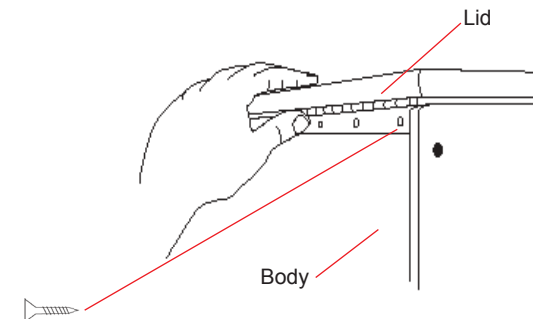

- Repeat steps 1, 2 and 3 to attach **Front** panel to body.
- With the box sitting flat on a hard surface, tighten all eight bolts.

Toy Storage Chest Assembly Instructions- Continued

7

- On a carpeted surface, gently lay the Toy Storage Chest on its back and open the lid so that it lays flat on the floor.
- Mount the top part of the Lid Support to the inside of the lid using 2 #8 screws.
- Be careful not to over tighten screws.

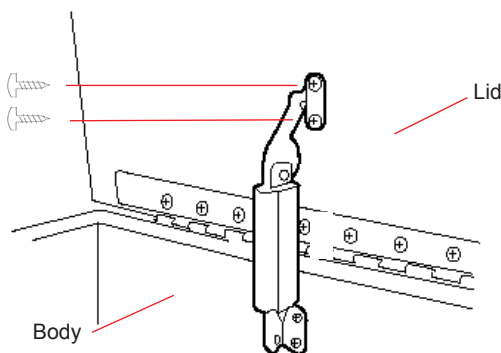

8

- Now that you have completed the assembly, open and close the lid 10 times to break in the lid support mechanism.
- The lid should not fall when the Lid Support is properly installed.
- If the lid does not stay in position when raised, please call us and we will help you. Until the lid support is properly installed, do not allow children to use this product. Please check the lid support mounting screws periodically to make sure they remain tight.

If you would like your Toy Storage Chest Personalized with your child's name. Contact us at 303 964 3212 and we will take your order and mail you your child's name complete with mounting instructions.



WARNING

Failure to properly install Lid Support will result in an entrapment hazard.

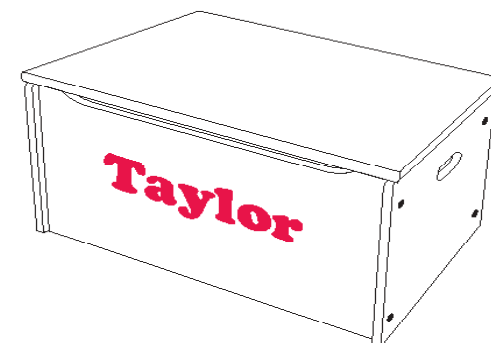

Use and Care Instructions

Use and care instructions:

The finish on this product is an environmentally friendly water base acrylic made by Sherwin Williams. It may be cleaned with a furniture polish, lemon oil or a non abrasive cleaner using a soft cloth. **DO NOT USE AMMONIA** or products containing ammonia such as Windex glass or multi-surface cleaner. Scuff marks can usually be removed by using a polishing compound sold at auto parts stores.

Little Colorado, Inc is a family run children's furniture manufacturer located in Denver. Please check out www.littlecolorado.com to see our other products that are all made here in America. The safety of your children is our highest concern. We are a **GREEN** company and hope you will be able to recycle the packaging material that we used to ship your product.

If you have a comment or a question please contact us at info@littlecolorado.com. All of us at Little Colorado hope you and your family will enjoy this product for many years.