

WASHERLESS

LAVATORY

Features:

- Metal Lever Handle
- Washerless Cartridge
- Max Flow Rate 2.0GPM(7.56LPM) at 60 PSI(ASME.A112.18.1M)



YP42VF-PC
Chrome Finish

YP42VF-BN
Brush Nickel Finish

YP42VF-ORB
Oil Rubbed Bronze Finish

Approval:
Meets or Exceeds The
following
*ANSI/ASME A112.18.1M
*ANSI/NSF 61-Sec.9
*IAPMO/UPC

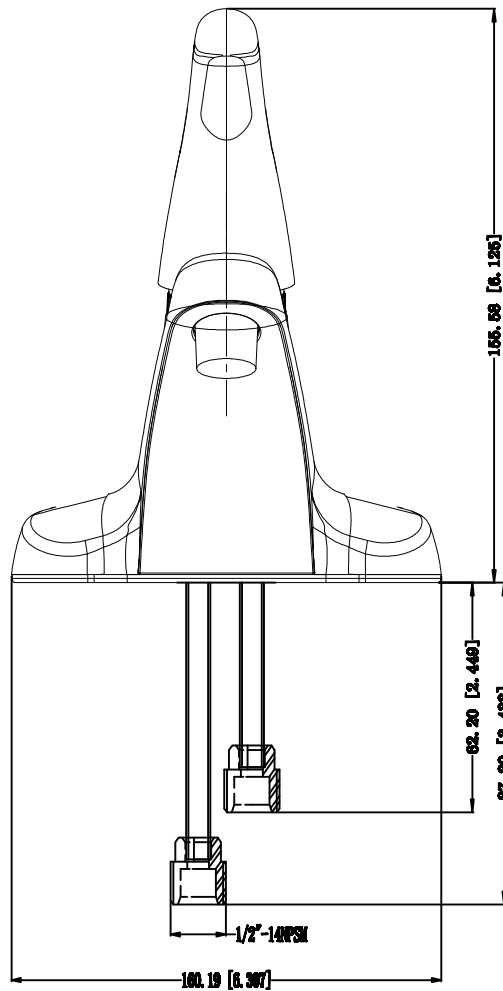
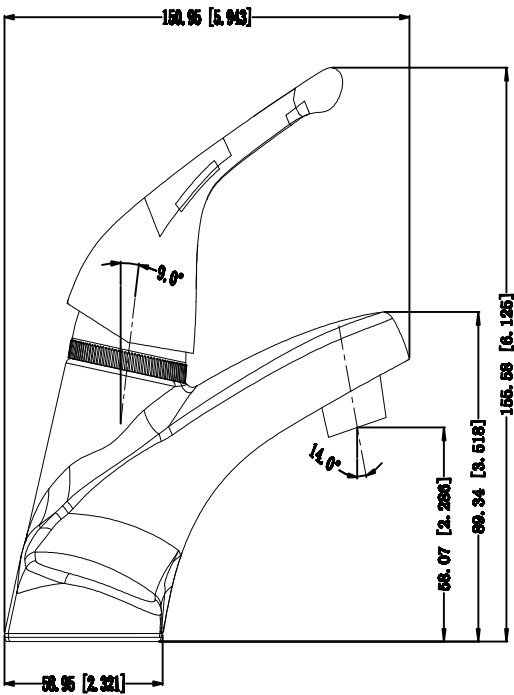

WASHERLESS

LAVATORY

Features:

- Metal Lever Handle
- Washerless Cartridge
- Max Flow Rate 2.0GPM(7.56LPM) at 60 PSI(ASME.A112.18.1M)



YP42VF-PC
Chrome Finish

YP42VF-BN
Brush Nickel Finish

YP42VF-ORB
Oil Rubbed Bronze Finish

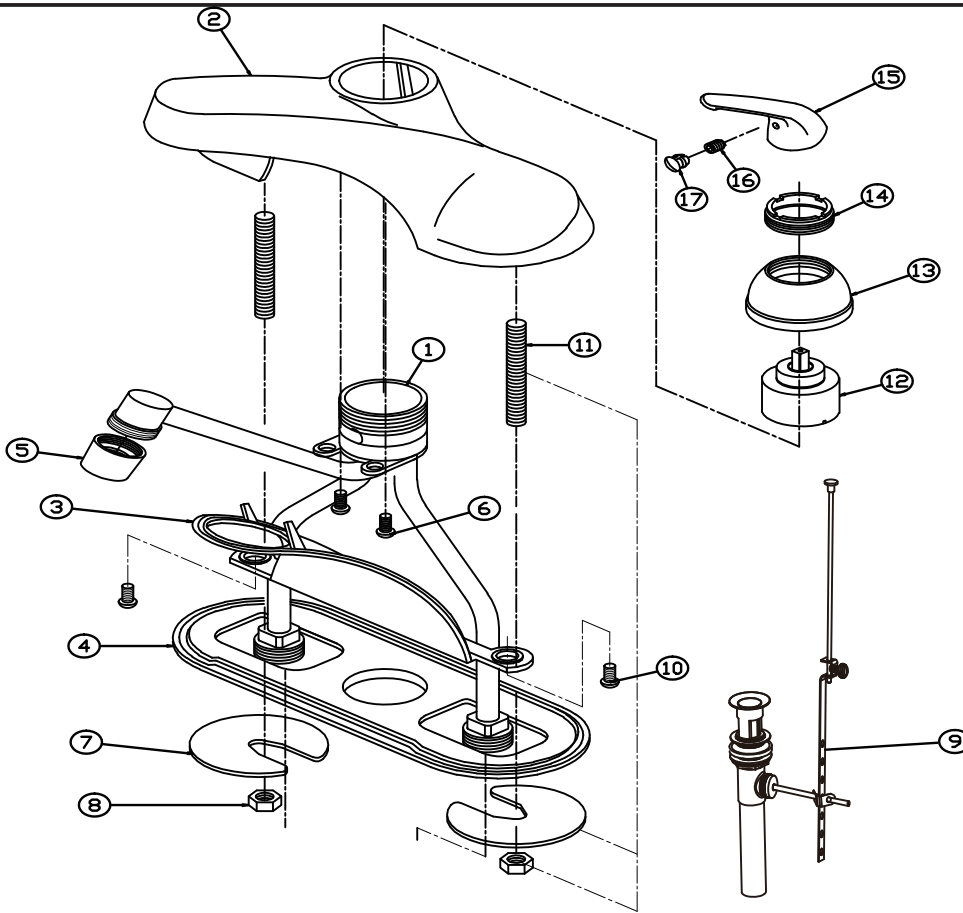

No.	Componet Description	No.	Componet Description
1	Mixer	10	Screw
2	Escutcheon	11	Fixing Screw Bolt
3	Back Bottom Plate	12	Cartridge
4	Front Bottom Plate	13	Metal Fixing Hat
5	Aerator	14	Adjustment Ring
6	Screw	15	Handle
7	Adjustment Ring	16	Screw
8	Pop-up	17	Hot and Cold Index Button
9	Washer	18	Handle

Approval:

Meets or Exceeds The following

- *ANSI/ASME A112.18.1M
- *ANSI/NSF 61-Sec.9
- *IAPMO/UPC

