

**HW16060
HIGHWAYconference chair**

DAUPHIN

**HW16070
HIGHWAYconf chr uphol front
and mesh in back**

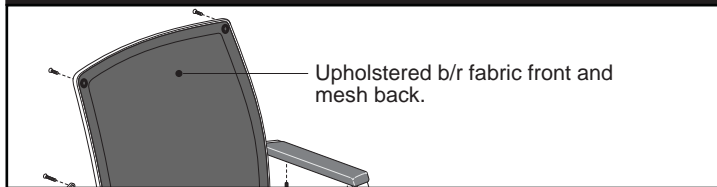

**HW16080
HIGHWAYconf chr uphol front
back and mesh in middle**

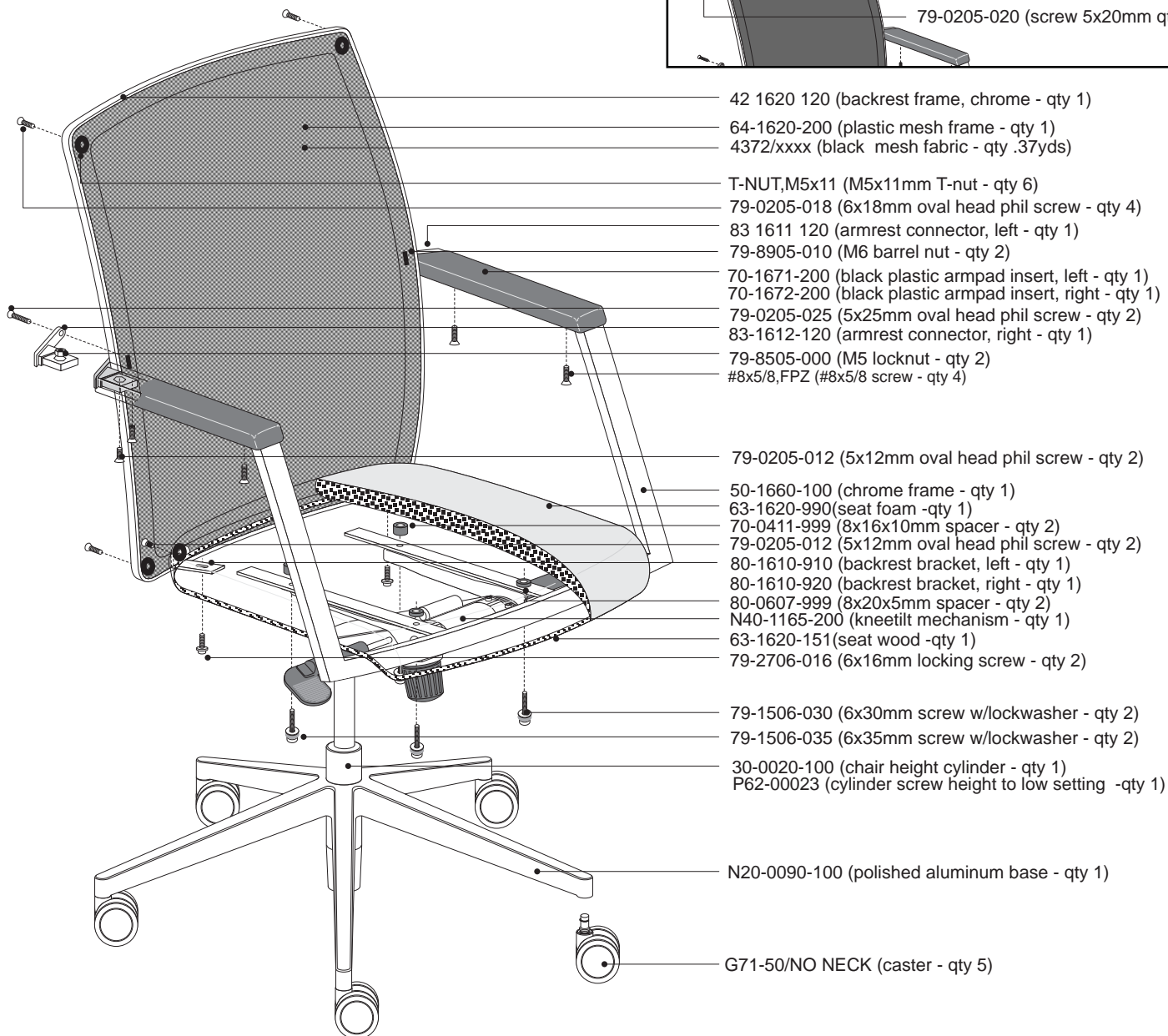
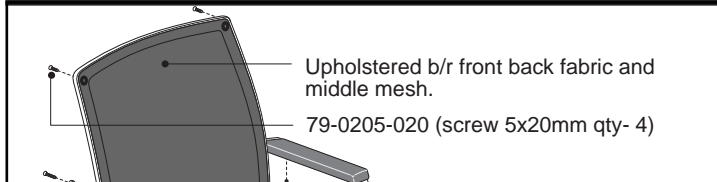

modified 08.29.09

Install T-nuts from front side of mesh frame. Flare with flathead screw from rear side. Tighten screw with screw gun until T-nut flares then remove screw. Cover T-nuts and barrel nuts with black electrical tape.