

G97044 Universal Storage Assembly Instructions

For ages 3 and up. Adult assembly required.

⚠ WARNING

Small parts and sharp points may be present prior to assembly.

Care Instructions

To clean your product, use mild soap and water on a damp cloth. Do not use window cleaners or cleaning abrasives as they will scratch the surface and could damage the protective coating.

Customer Service

For questions regarding this product, or to receive replacement or missing parts, contact Customer Service at (800) 524-3555. Please have the model number and part number(s) located in this Assembly Instruction sheet available for reference.

Limited Warranty

All Guidecraft products are warranted to the original purchaser at the time of purchase and for a period of one (1) year thereafter. In order to provide you with timely assistance, please thoroughly inspect your product for missing or defective parts immediately after opening the carton. To receive replacement or missing parts under this warranty, contact Customer Service. You will also need your sales receipt or other proof of purchase.

Hardware and Parts

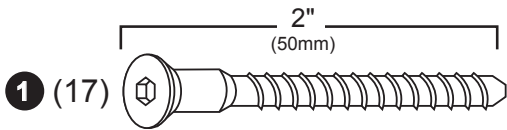

2 (6)

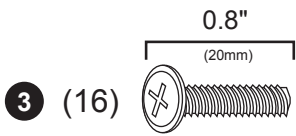

4 (8)

5 (4)

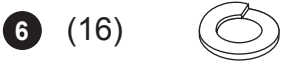

7 (16)

8 (4)



10 (8)

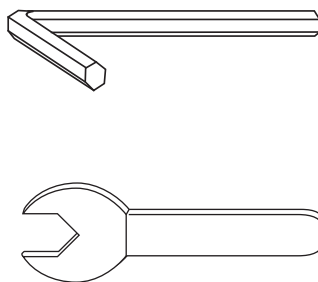
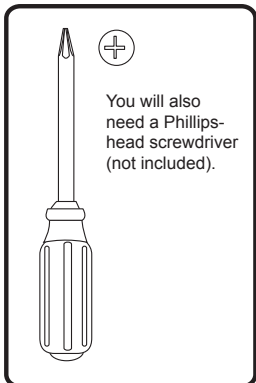
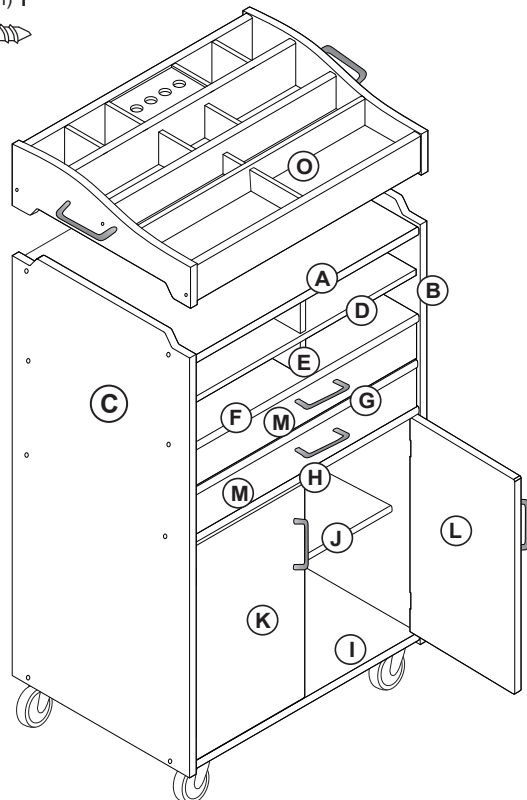

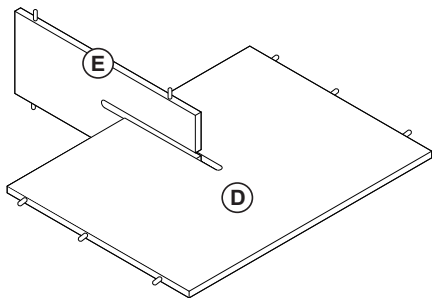

Step 1

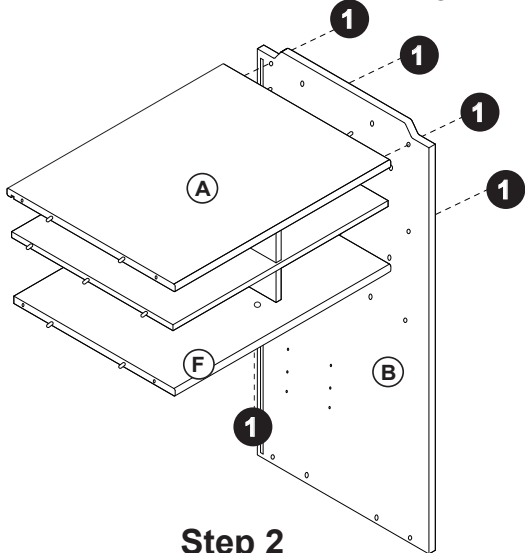

Step 2

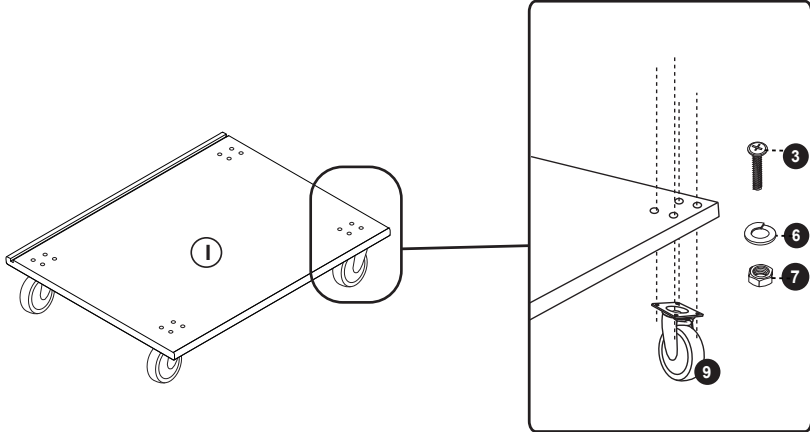

Step 3

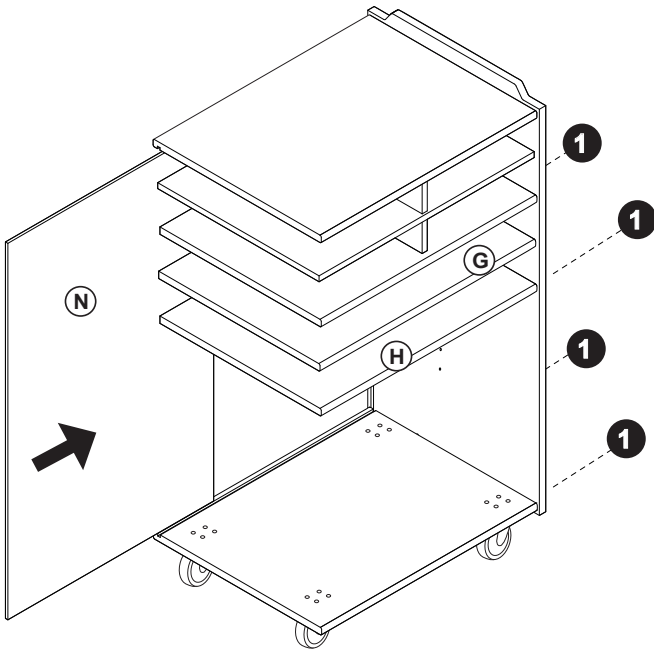

Step 4

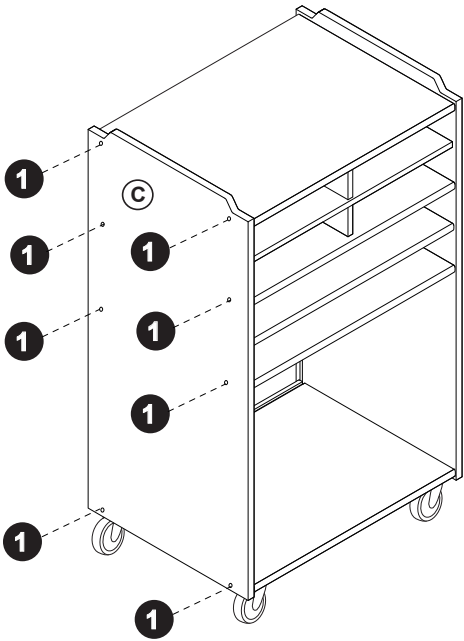

Step 5

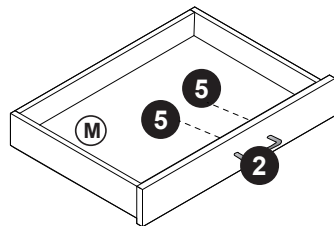
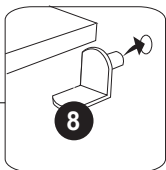
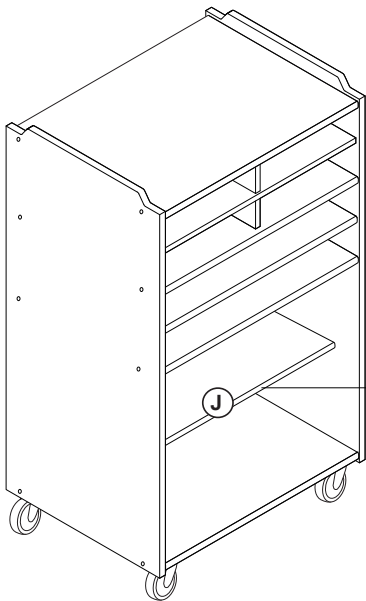

Step 6

Step 7

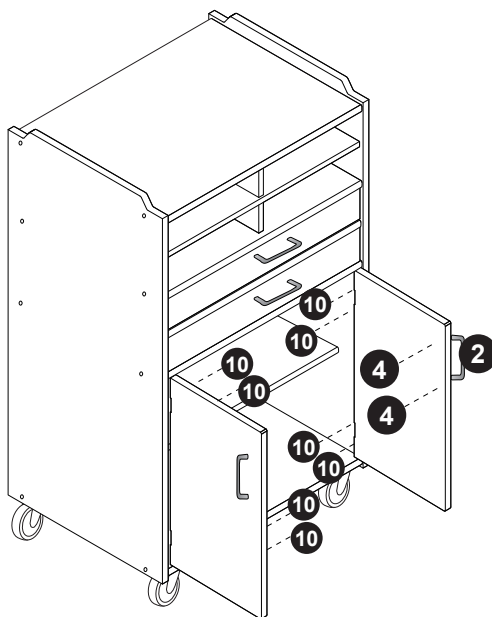

Step 8

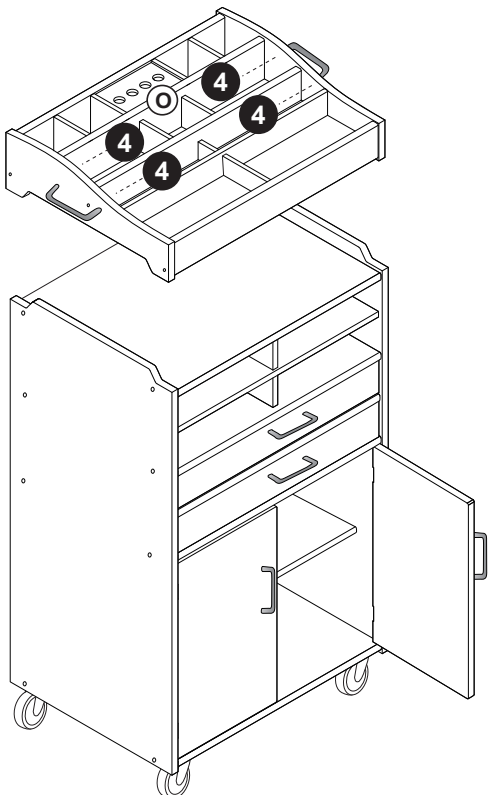

Step 9

