

CHAMPION

GLOBAL POWER EQUIPMENT™

OWNER'S MANUAL & OPERATING INSTRUCTIONS



6800 Starting Watts / 5500 Rated Watts

PORTABLE GENERATOR



MODEL NUMBER

41135

SAVE THESE INSTRUCTIONS
Important Safety Instructions
are included in this manual.

MADE IN CHINA
REV 41135-20110701

10006 Santa Fe Springs Road
Santa Fe Springs CA 90670
USA / 1-877-338-0999
www.championpowerequipment.com

Have questions or need assistance?

Do not return this product to the store!

WE ARE HERE TO HELP!

Visit our website:

www.championpowerequipment.com

for more info:

- Product Info & Updates
- Tech Bulletins
- Frequently Asked Questions
- Product Registration

– or –

Call our Customer Care Team Toll-Free at:

1-877-338-0999

24/7 Tech Support: (562) 204-1188

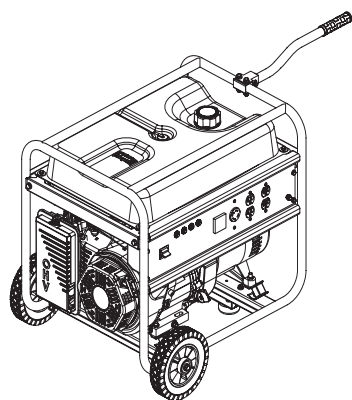

6800 Starting Watts / 5500 Rated Watts PORTABLE GENERATOR

TABLE OF CONTENTS

| | | | |
|---|-----------|---|-----------|
| Introduction | 1 | Cleaning | 14 |
| Introduction | 1 | Adjustments | 14 |
| Portable Power Generator | 1 | Maintenance Schedule | 14 |
| Accessories | 1 | Generator Maintenance | 15 |
| This Booklet | 1 | Storage | 15 |
| Manual Conventions | 2 | Generator Storage | 15 |
| Safety Rules | 3 | Specifications | 16 |
| Controls and Features | 5 | Engine Specifications | 16 |
| Generator | 5 | Generator Specifications | 18 |
| Power Panel | 6 | Fuel | 16 |
| Parts Included | 7 | Oil | 16 |
| Wheel Kit | 7 | Spark Plugs | 16 |
| Other | 7 | Valve Clearance | 16 |
| Assembly | 8 | Parts Diagram | 17 |
| Remove the Generator from the Shipping Carton | 8 | Parts List | 18 |
| Install the Wheel Kit | 8 | Engine Parts Diagram | 19 |
| Install the Support Leg | 8 | Engine Parts List | 20 |
| Add Engine Oil | 8 | Wiring Diagram | 21 |
| Add Fuel | 9 | Troubleshooting | 22 |
| Grounding | 9 | Warranty | 23 |
| Operation | 10 | Warranty Qualifications | 23 |
| Generator Location | 10 | Repair/Replacement Warranty | 23 |
| Grounding | 10 | Do Not Return The Unit To | 23 |
| Surge Protection | 10 | The Place Of Purchase | 23 |
| Starting the Engine | 10 | Warranty Exclusions | 23 |
| Connecting Electrical Loads | 11 | Normal Wear | 23 |
| Stopping the Engine | 11 | Installation, Use and Maintenance | 23 |
| Do Not Overload Generator | 11 | Other Exclusions | 23 |
| Capacity | 11 | Limits of Implied Warranty | 23 |
| Power Management | 11 | and Consequential Damage | 23 |
| Wattage Reference Chart | 12 | Contact Information | 23 |
| Operation at High Altitude | 12 | Address | 23 |
| Maintenance and Storage | 13 | Customer Service | 23 |
| Engine Maintenance | 13 | Technical Service | 23 |
| Oil | 13 | | |
| Spark Plugs | 13 | | |
| Air Filter | 13 | | |
| Spark Arrester | 14 | | |

INTRODUCTION

Introduction

Congratulations on your purchase of a Champion Power Equipment generator. CPE designs and builds generators to strict specifications. With proper use and maintenance, this generator will bring years of satisfying service.

Portable Power Generator

This unit is a gasoline engine driven, alternating current (AC) generator. It is designed to supply electrical power for lighting, appliances, tools and similar equipment.

Accessories

Champion Power Equipment manufactures and sells accessories designed to help you get the most from your purchase. To find out more about our covers, power cables and storm kits, please visit our web site at:
→ www.championpowerequipment.com

This Booklet

Every effort has been made to ensure the accuracy and completeness of the information in this manual. We reserve the right to change, alter and/or improve the product and this document at any time without prior notice.

Record the model and serial numbers as well as date and place of purchase for future reference. Have this information available when ordering parts and when making technical or warranty inquiries.

| Champion Power Equipment Support | |
|--|--|
| 1-877-338-0999 | |
| Model Number | |
| 41135 | |
| Serial Number | |
| | |
| Date of Purchase | |
| | |
| Purchase Location | |
| | |
| For Oil Type see 'Add Engine Oil' section. For Fuel Type see 'Add Fuel' section. | |

This manual uses the following symbols to help differentiate between different kinds of information. The safety symbol is used with a key word to alert you to potential hazards in operating and owning power equipment.

Follow all safety messages to avoid or reduce the risk of serious injury or death.

 **DANGER**

DANGER indicates an imminently hazardous situation which, if not avoided, **will** result in death or serious injury.

 **WARNING**

WARNING indicates a potentially hazardous situation which, if not avoided, **could** result in death or serious injury.

 **CAUTION**

CAUTION indicates a potentially hazardous situation which, if not avoided, **may** result in minor or moderate injury.

CAUTION

CAUTION used without the safety alert symbol indicates a potentially hazardous situation which, if not avoided, **may** result in property damage.

 **NOTE**

If you have questions regarding your generator, we can help. Please call our help line at **1-877-338-0999**

SAFETY RULES

WARNING

Read this manual thoroughly before operating your generator. Failure to follow instructions could result in serious injury or death.

WARNING

The engine exhaust from this product contains chemicals known to the state of California to cause cancer, birth defects, or other reproductive harm.

DANGER

Generator exhaust contains carbon monoxide, a colorless, odorless, poison gas. Breathing carbon monoxide will cause nausea, dizziness, fainting or death. If you start to feel dizzy or weak, get to fresh air immediately.

Operate generator outdoors only in a well ventilated area.

DO NOT operate the generator inside any building, including garages, basements, crawlspaces and sheds, enclosure or compartment, including the generator compartment of a recreational vehicle. DO NOT allow exhaust fumes to enter a confined area through windows, doors, vents or other openings.

DANGER CARBON MONOXIDE: using a generator indoors **CAN KILL YOU IN MINUTES.**

DANGER

Rotating parts can entangle hands, feet, hair, clothing and/or accessories.
Traumatic amputation or severe laceration can result.

Keep hands and feet away from rotating parts.
Tie up long hair and remove jewelry.
Operate equipment with guards in place.
DO NOT wear loose-fitting clothing, dangling drawstrings or items that could become caught.

DANGER

Generator produces powerful voltage.

DO NOT touch bare wires or receptacles.

DO NOT use electrical cords that are worn, damaged or frayed.

DO NOT operate generator in wet weather.

DO NOT allow children or unqualified persons to operate or service the generator

Use a ground fault circuit interrupter (GFCI) in damp areas and areas containing conductive material such as metal decking.

Use approved transfer equipment to isolate generator from your electric utility and Notify your utility company before connecting your generator to your power system.

WARNING

Sparks can result in fire or electrical shock.

When servicing the generator:

Disconnect the spark plug wire and place it where it cannot contact the plug.

DO NOT check for spark with the plug removed.

Use only approved spark plug testers.

WARNING

Running engines produce heat. Severe burns can occur on contact.

Combustible material can catch fire on contact.

DO NOT touch hot surfaces.

Avoid contact with hot exhaust gases.

Allow equipment to cool before touching.

Maintain at least three feet of clearance on all sides to ensure adequate cooling.

Maintain at least five feet of clearance from combustible materials.

⚠ DANGER

Fuel and fuel vapors are highly flammable and extremely explosive.
Fire or explosion can cause severe burns or death.
Unintentional startup can result in entanglement, traumatic amputation or laceration.

When adding or removing fuel:

Turn the generator off and let it cool for at least two minutes before removing the fuel cap. Loosen the cap slowly to relieve pressure in the tank.
Only fill or drain fuel outdoors in a well-ventilated area.
DO NOT overfill the fuel tank.
Always keep fuel away from sparks, open flames, pilot lights, heat and other sources of ignition.
DO NOT light or smoke cigarettes.

When starting the generator:

DO NOT attempt to start a damaged generator.
Make certain that the gas cap, air filter, spark plug, fuel lines and exhaust system are properly in place.
Allow spilled fuel to evaporate fully before attempting to start the engine.
Make certain that the generator is resting firmly on level ground.

When operating the generator:

DO NOT move or tip the generator during operation.
DO NOT tip the generator or allow fuel or oil to spill.

When transporting or servicing the generator:

Make certain that the fuel shutoff valve is in the off position and the fuel tank is empty.
Disconnect the spark plug wire.
When storing the generator:
Store away from sparks, open flames, pilot lights, heat and other sources of ignition.

⚠ WARNING

Operation of this equipment may create sparks that can start fires around dry vegetation.

A spark arrestor may be required. The operator should contact local fire agencies for laws or regulations relating to fire prevention requirements.

⚠ WARNING

Rapid retraction of the starter cord will pull hand and arm towards the engine faster than you can let go.
Unintentional startup can result in entanglement, traumatic amputation or laceration.
Broken bones, fractures, bruises or sprains could result.

When starting engine, pull the starter cord slowly until resistance is felt and then pull rapidly to avoid kickback.
DO NOT start or stop the engine with electrical devices plugged in.

⚠ CAUTION

Exceeding the generator's running capacity can damage the generator and/or electrical devices connected to it.

DO NOT overload the generator.
Start the generator and allow the engine to stabilize before connecting electrical loads.
Connect electrical equipment in the off position, and then turn them on for operation.
Turn electrical equipment off and disconnect before stopping the generator.
DO NOT tamper with the governed speed.
DO NOT modify the generator in any way.

⚠ CAUTION

Improper treatment or use of the generator can damage it, shorten its life and void your warranty.

Use the generator only for intended uses.
Operate only on level surfaces.
DO NOT expose generator to excessive moisture, dust, or dirt.
DO NOT allow any material to block the cooling slots.
If connected devices overheat, turn them off and disconnect them from the generator.
DO NOT use the generator if:

- Electrical output is lost
- Equipment sparks, smokes or emits flames
- Equipment vibrates excessively

CONTROLS AND FEATURES

Read this owner's manual before operating your generator. Familiarize yourself with the location and function of the controls and features. Save this manual for future reference.

Generator

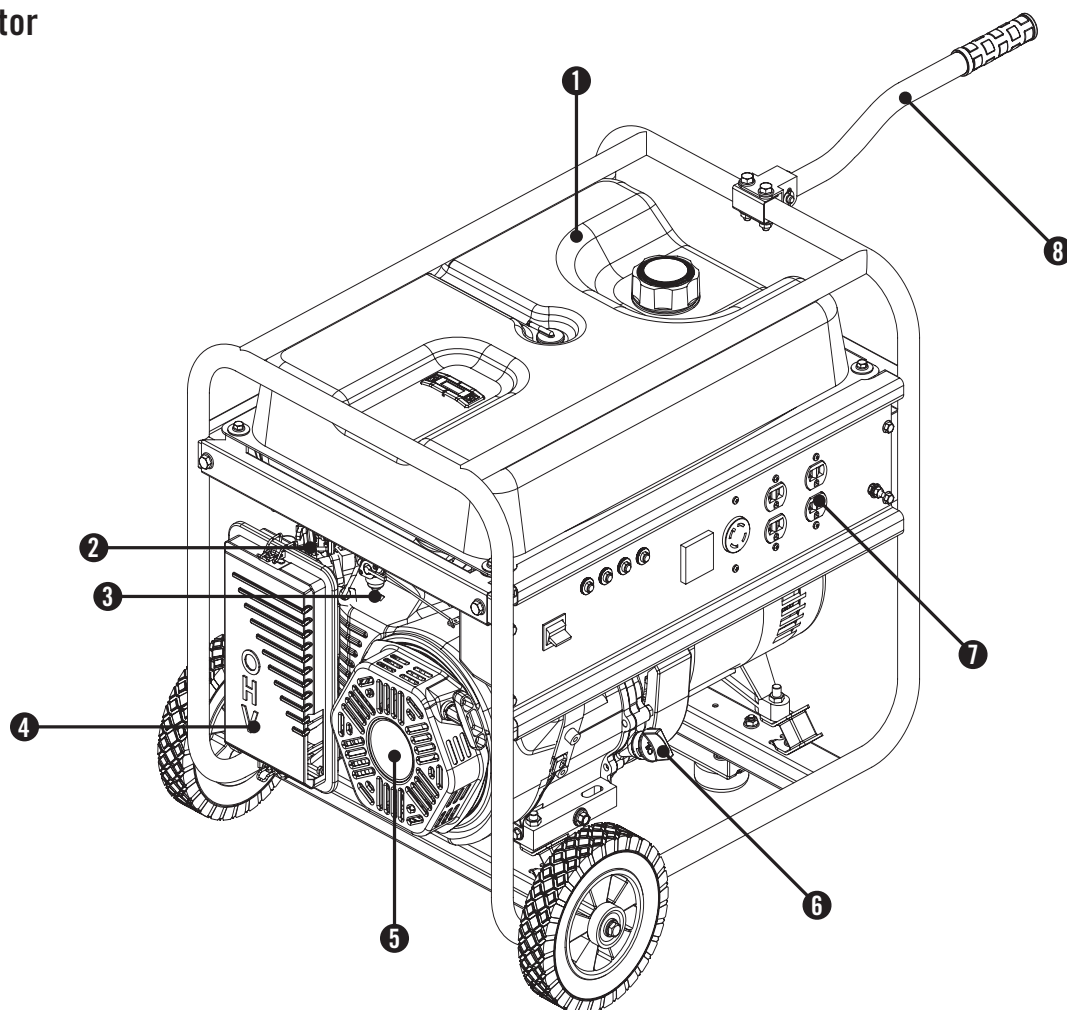

- | | |
|--|--|
| (1) Fuel Tank – 5.9 gallon (22.4 L) capacity fuel tank. | (5) Recoil Starter – Used to start the engine. |
| (2) Choke – Used to start the engine. | (6) Oil Filler Cap – Check and fill engine oil level. |
| (3) Fuel Valve – Turn this valve to the “ON” position to supply fuel to the engine. | (7) Power Panel – See “Power Panel” section. |
| (4) Air Cleaner – Protects the engine by filtering dust and debris from the intake air. | (8) Fold Away Handle |

Power Panel

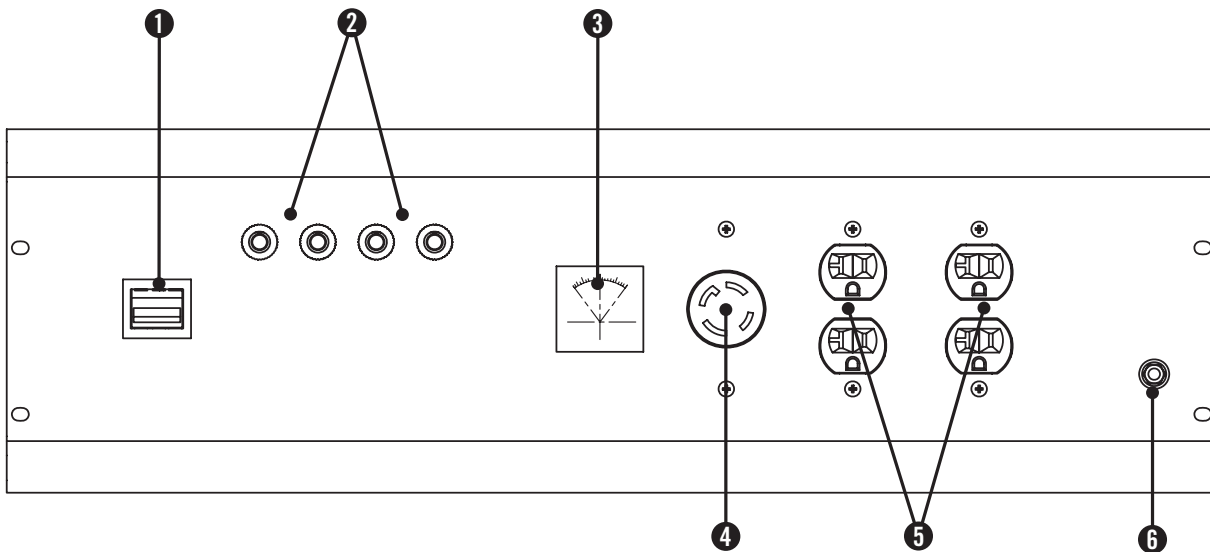

- (1) **Engine Switch** – Used to turn the generator on and off.
- (2) **Circuit Breakers** – Protects the generator against electrical overloads. Push to reset breaker.
- (3) **Voltmeter** – Used to display alternator output voltage.
- (4) **120/240 Volt AC, 30 Amp Twist-Lock Receptacle** (NEMA L14-30R) – May be used to supply electrical power for the operation of 120 and/or 240 Volt AC, 30 Amp, single phase 60 Hz electrical loads.
- (5) **120 Volt AC, 20 Amp Duplex (2)** (NEMA 5-20R) – May be used to supply electrical power for the operation of 120 Volt AC, 20 Amp, single phase 60 Hz electrical loads.
- (6) **Ground Terminal** – Consult an electrician for local grounding regulations.

CONTROLS AND FEATURES

Parts Included

Your 41135 Gasoline Powered Generator ships with the following parts:

Wheel Kit

- 8" Wheel 2
- Flange Bolt (M10x105 for Wheel) 2
- Bushing 2
- Flat Washer 10 2
- Nut (M10) 2
- Handle 1
- Support Leg w/Vibration Mounts 1
- Flange Bolt (M8x45 for Vibration Mounts) 2
- Flange Bolt (M8x25 for Vibration Mounts) 2
- Flange Bolt (M8x16 for Support Leg) 2
- Nut (M8) 6

Other

- Oil Funnel 1
- Spark Plug Socket 1

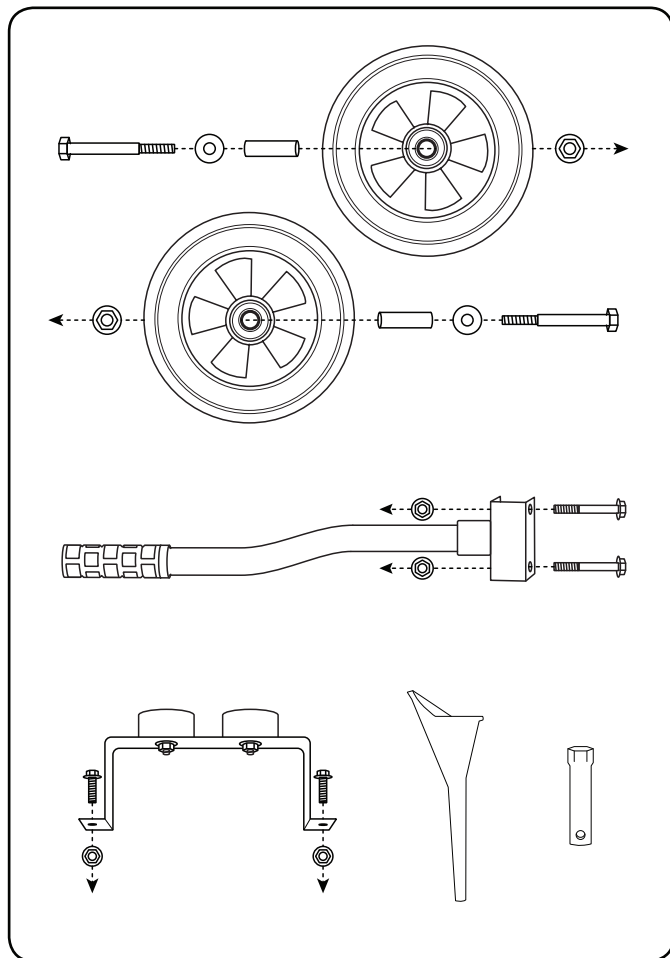

Your generator requires some assembly. This unit ships from our factory without oil. It must be properly serviced with fuel and oil before operation.

If you have any questions regarding the assembly of your generator, call our help line at 1-877-338-0999. Please have your serial number and model number available.

Remove the Generator from the Shipping Carton

1. Set the shipping carton on a solid, flat surface.
2. Remove everything from the carton except the generator.
3. Carefully cut each corner of the box from top to bottom. Fold each side flat on the ground to provide a surface area to install the wheel kit and support leg.

Install the Wheel Kit

⚠ CAUTION

The wheel kit is not intended for over-the-road use.

You will need the following tools to install the wheels:

- 17 mm wrench OR adjustable wrench (not included)
- Socket wrench with a 16 mm socket (not included)
- Pliers (not included)

1. Before adding fuel and oil, tip the generator on its side.
2. Slide the M10x105 wheel bolt through the washer, sleeve and wheel.
3. Slide the bolt through the mount point on the frame.
4. Fasten securely with the M10 nut.
5. Repeat steps 2-4 to attach the second wheel.

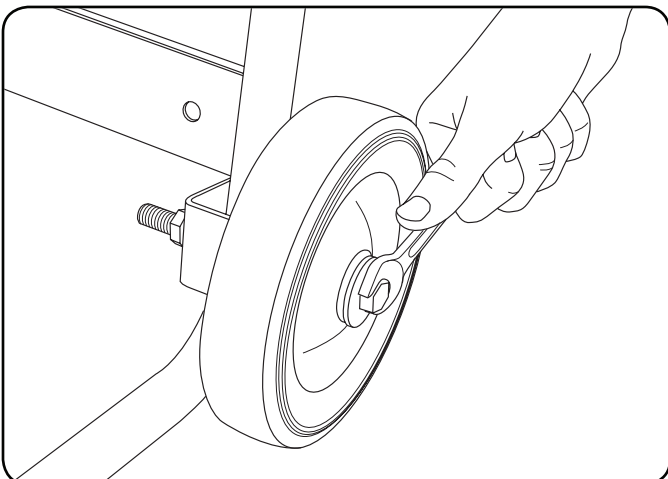

Install the Support Leg

1. Attach the support leg to the generator frame with cap screws (M8x16) and nuts (M8).
2. Tip the generator slowly so that it rests on the wheels and support leg.

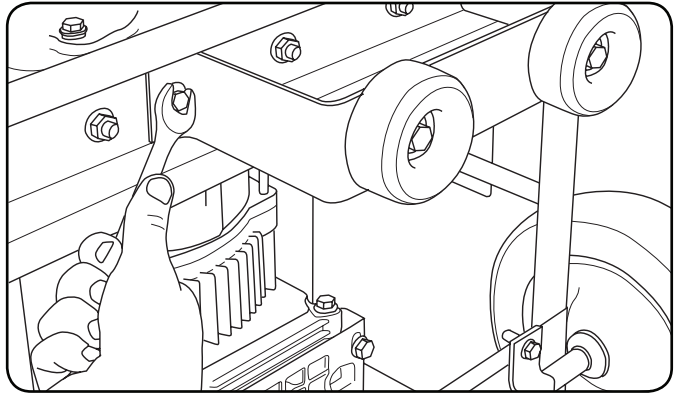

Install the Handles

1. Place the handle over the mounting channel on the frame.
2. Secure the handle to the frame using the two handle bolts (M8x45).
3. Place a lock nut (M8) on the end of each bolt and fasten securely. DO NOT over tighten the lock nuts.

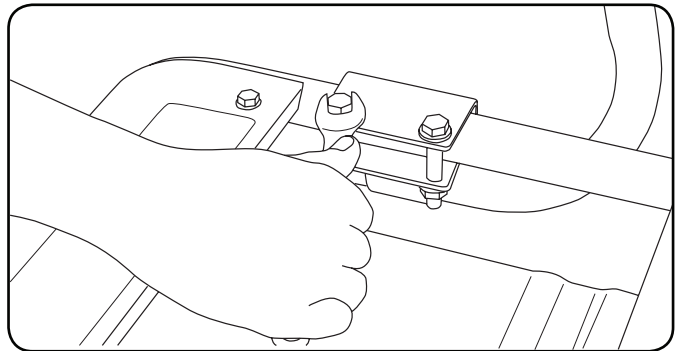

Add Engine Oil

⚠ CAUTION

DO NOT attempt to crank or start the engine before it has been properly filled with the recommended type and amount of oil. Damage to the generator as a result of failure to follow these instructions will void your warranty.

NOTE

The recommended oil type is 10W-30 4-cycle automotive oil.

1. Place the generator on a flat, level surface.

ASSEMBLY

Add Engine Oil Cont'd.

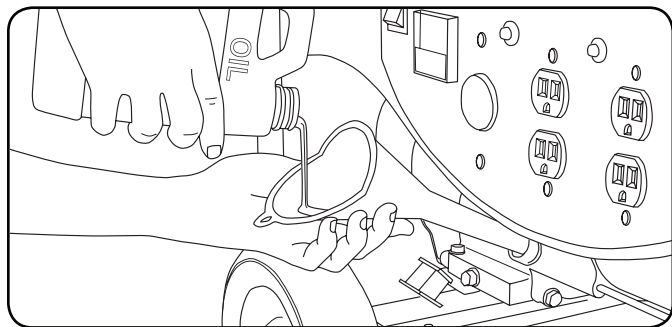

- Remove oil fill cap/dipstick to add oil.
- Add 1.16 qt (1.1 L) of oil and replace oil fill cap/dipstick. See "Specifications" pages for oil recommendations based on operating conditions.

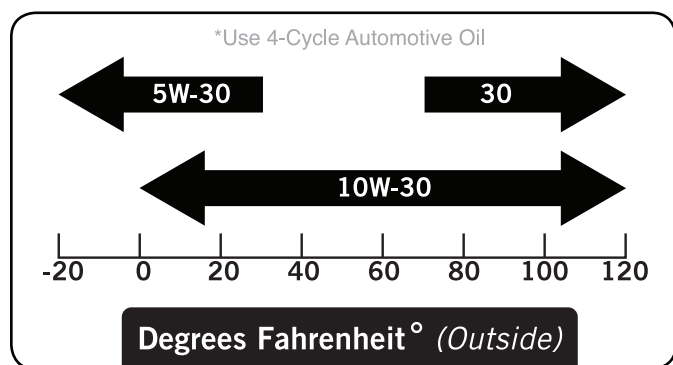

- Check engine oil level daily and add as needed.

CAUTION

The engine is equipped with a low-oil-shutoff and will stop when the oil level in the crankcase falls below the threshold level.

NOTE

Check oil often during the break-in period. Refer to the Maintenance section for recommended service intervals.

NOTE

The generator rotor has a sealed, pre-lubricated ball bearing that requires no additional lubrication for the life of the bearing.

Add Fuel

- Use clean, fresh, regular unleaded fuel with a minimum octane rating of 85 and an ethanol content of less than 10% by volume.
- DO NOT mix oil with fuel.

Add Fuel Cont'd.

- Clean the area around the fuel cap.
- Remove the fuel cap.
- Slowly add fuel to the tank. DO NOT overfill. Allow approximately ¼ inch of space for fuel expansion.

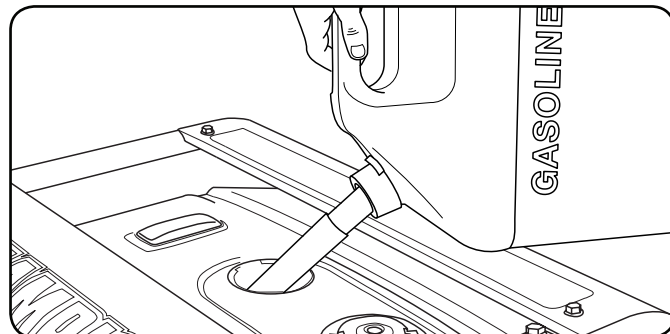

- Screw on the fuel cap and wipe away any spilled fuel.

! CAUTION

Use regular unleaded gasoline with a minimum octane rating of 85.

DO NOT mix oil and gasoline.

Fill tank to approximately ¼ inch below the top of the tank to allow for fuel expansion.

DO NOT fill fuel tank indoors.

DO NOT fill fuel tank when the engine is running or hot.

DO NOT overfill the fuel tank.

DO NOT light cigarettes or smoke when filling the fuel tank.

Grounding

Your generator must be properly connected to an appropriate ground to help prevent electric shock.

! WARNING

Failure to properly ground the generator can result in electric shock.

A ground terminal connected to the frame of the generator has been provided on the power panel. For remote grounding, connect a length of heavy gauge (12 AWG minimum) copper wire between the generator ground terminal and a copper rod driven into the ground. We strongly recommend that you consult with a qualified electrician to ensure compliance with local electrical codes.

Generator Location

Please consult your local authority. In some areas, generators must be registered with the local utility. Generators used at construction sites may be subject to additional rules and regulations.

This generator must have at least five feet of clearance from combustible material. Leave at least three feet of clearance on all sides of the generator to allow for adequate cooling, maintenance and servicing.

Place the generator in a well-ventilated area. DO NOT place the generator near vents or intakes where exhaust fumes could be drawn into occupied or confined spaces. Carefully consider wind and air currents when positioning generator.

Grounding

The generator system ground connects the frame to the ground terminals on the power panel.

The generator (stator winding) is isolated from the frame and from the AC receptacle ground pin. Electrical devices that require a grounded receptacle pin connection may not function properly.

Surge Protection

CAUTION

Voltage fluctuation may impair the proper functioning of sensitive electronic equipment.

Electronic devices, including computers and many programmable appliances use components that are designed to operate within a narrow voltage range and may be affected by momentary voltage fluctuations. While there is no way to prevent voltage fluctuations, you can take steps to protect sensitive electronic equipment.

1. *Install UL1449, CSA-listed, plug-in surge suppressors on the outlets feeding your sensitive equipment.*

Surge suppressors come in single- or multi-outlet styles. They're designed to protect against virtually all short-duration voltage fluctuations.

Starting the Engine

1. Make certain the generator is on a flat, level surface.
2. Disconnect all electrical loads from the generator. Never start or stop the generator with electrical devices plugged in or turned on.
3. Turn the Fuel Valve to the "ON" position.
4. Flip the ignition switch to the "ON" position.
5. Move the choke lever to the "CHOKE" position.
6. RECOIL START: Pull the starter cord slowly until resistance is felt and then pull rapidly
7. Do not over-choke. As soon as engine starts, move the choke lever to the "RUN" position.

NOTE

Keep choke lever in "Choke" position for only 1 pull of the recoil starter. After first pull, move choke lever to the "Run" position for up to the next 3 pulls of the recoil starter. Too much choke leads to sparkplug fouling/engine flooding due to the lack of incoming air. This will cause the engine not to start.

NOTE

If the engine starts but does not run make certain that the generator is on a flat, level surface. The engine is equipped with a low oil sensor that will prevent the engine from running when the oil level falls below a critical threshold.

OPERATION

Connecting Electrical Loads

1. Let the engine stabilize and warm up for a few minutes after starting
2. Plug in and turn on the desired 120/240 Volt AC single phase, 60 Hz electrical loads.
 - DO NOT connect 3-phase loads to the generator.
 - DO NOT connect 50 Hz loads to the generator.
 - DO NOT overload the generator.

NOTE

Connecting a generator to your electric utility company's power lines or to another power source may be against the law. In addition this action, if done incorrectly, could damage your generator and appliances and could cause serious injury or even death to you or a utility worker who may be working on nearby power lines. If you plan to run a portable electric generator during an outage, please notify your electric utility company immediately and remember to plug your appliances directly into the generator. Do not plug the generator into any electric outlet in your home. Doing so could create a connection to the utility company power lines. You are responsible for ensuring that your generator's electricity does not feed back into the electric utility power lines.

If the generator will be connected to a building electrical system, consult your local utility company or a qualified electrician. Connections must isolate generator power from utility power and must comply with all applicable laws and codes.

Stopping the Engine

1. Turn off and unplug all electrical loads. Never start or stop the generator with electrical devices plugged in or turned on.
2. Let the generator run at no-load for several minutes to stabilize internal temperatures of the engine and generator.
3. Press the ignition switch to the "OFF" position.
4. Turn the Fuel Valve to the "OFF" position.

Important: If the generator will be moved or stored turn the Fuel Valve to the "OFF" position and ensure the Ignition Switch on the Power Panel is in the "OFF" position.

Do Not Overload Generator

Capacity

Follow these simple steps to calculate the running and starting watts necessary for your purposes.

1. Select the electrical devices you plan on running at the same time.
2. Total the running watts of these items. This is the amount of power you need to keep your items running.
3. Identify the highest starting wattage of all devices identified in step 1. Add this number to the number calculated in step 2. Surge wattage is the extra burst of power needed to start some electric driven equipment. Following the steps listed under "Power Management" will guarantee that only one device will be starting at a time.

Power Management

Use the following formula to convert voltage and amperage to watts:

$$\text{Volts} \times \text{Amps} = \text{Watts}$$

To prolong the life of your generator and attached devices, follow these steps to add electrical load:

1. Start the generator with no electrical load attached
2. Allow the engine to run for several minutes to stabilize.
3. Plug in and turn on the first item. It is best to attach the item with the largest load first.
4. Allow the engine to stabilize.
5. Plug in and turn on the next item.
6. Allow the engine to stabilize.
7. Repeat steps 5-6 for each additional item.

NOTE

Never exceed the specified capacity when adding loads to the generator.

Wattage Reference Chart

Use the chart to determine approximate wattage requirements for your equipment.

CAUTION

Exceeding specified load capacity can result in damage to the generator.

To determine total wattage necessary to power a device, **ADD Running Watts to Starting Watts**. (A+B). Starting watts can exceed three times the running watts. The values in the following table are approximate. Refer to your tool or appliance for actual wattage consumption.

| Item | Running Watts (A) | Starting Watts (B) |
|------------------------------|-------------------|--------------------|
| Essentials | | |
| Light Bulb 100W | 100 | |
| Refrigerator/Freezer | 1200 | 2400 |
| Freezer | 500 | 500 |
| Sump Pump | 600 | 1800 |
| Well Pump 1 HP | 2000 | 4000 |
| Water Heater | 4000 | |
| Security System | 180 | |
| AM/FM Radio | 300 | |
| Garage Door Opener 1/2 HP | 500 | 600 |
| Battery Charger 12V DC | 110 | |
| Heating/Cooling | | |
| Air Conditioner 12000 BTU | 1700 | 2500 |
| Fan | 300 | 600 |
| Furnace Fan 1/3 HP | 1200 | 2000 |
| Home Appliances | | |
| Microwave 1000W | 1000 | |
| Electric Range - One Element | 1500 | |
| Electric Skillet | 1250 | |
| Coffee Maker | 1500 | |
| Clothes Washer | 1200 | |
| Entertainment | | |
| CD/DVD Player / VCR | 100 | |
| Stereo Receiver | 450 | |
| Television 27" | 500 | |
| PC with 15" Monitor | 800 | |
| Job Site | | |
| Belt Sander 3" | 1000 | 1500 |
| Bench Grinder 6" | 700 | 1500 |
| Circular Saw | 1500 | 1500 |
| Compressor 1 1/2 HP | 2500 | 2500 |
| Edge Trimmer | 500 | 500 |
| Hand Drill 1/2" | 1000 | 1000 |
| Lawn Mower | 1200 | 1800 |
| Paint Sprayer | 600 | 1200 |
| Table Saw | 2000 | 2000 |

Operation at High Altitude

The density of air at high altitude is lower than at sea level. Engine power is reduced as the air mass and air-fuel ratio decrease. Engine power and generator output will be reduced approximately 3½% for every 1000 feet of elevation above sea level. This is a natural trend and cannot be changed by adjusting the engine. At sufficiently high altitudes increased exhaust emissions can also result due to the increased enrichment of the air fuel ratio. Other high altitude issues can include hard starting, increased fuel consumption and spark plug fouling.

To alleviate high altitude issues other than the natural power loss, Champion Power Equipment can provide a high altitude carburetor main jet. The alternative main jet and installation instructions can be obtained by contacting Customer Support. Installation instructions are also available in the Technical Bulletin area of the Champion Power Equipment internet site.

The part number and recommended minimum altitude for the application of the high altitude carburetor main jet is listed in the table below.

| | Part Number | Altitude |
|-------------------|--------------------|---------------|
| Standard main jet | ST182FD-1131000-17 | 5000 Feet |
| Altitude main jet | 182.131017.01 | (1500 Meters) |

WARNING

Operation using the alternative main jet at elevations lower than the recommended minimum altitude can damage the engine. For operation at lower elevations, the standard main jet must be used. Operating the engine with the wrong engine configuration at a given altitude may increase its emissions and decrease fuel efficiency and performance.

MAINTENANCE AND STORAGE

The owner/operator is responsible for all periodic maintenance.

WARNING

Never operate a damaged or defective generator.

WARNING

Tampering with the factory set governor will void your warranty.

WARNING

Improper maintenance will void your warranty.

NOTE

Maintenance, replacement, or repair of emission control devices and systems may be performed by any non-road engine repair establishment or individual.

Complete all scheduled maintenance in a timely manner. Correct any issue before operating the generator.

NOTE

For service or parts assistance, contact our help line at **1-877-338-0999**

Engine Maintenance

To prevent accidental starting, remove and ground spark plug wire before performing any service.

Oil

Change oil when the engine is warm. Refer to the oil specification to select the proper grade of oil for your operating environment.

1. Remove the oil drain plug with a 15 mm socket and extension.
2. Allow the oil to drain completely.
3. Replace the drain plug.
4. Remove oil fill cap/dipstick to add oil.
5. Add 1.16 qt (1.1 L) of oil and replace oil fill cap/dipstick.
6. Dispose of used oil at an approved waste management facility.

Oil Cont'd.

NOTE

Once oil has been added, a visual check should show oil about 1-2 threads from running out of the fill hole. If using the dipstick to check oil level, **DO NOT** screw in the dipstick while checking.

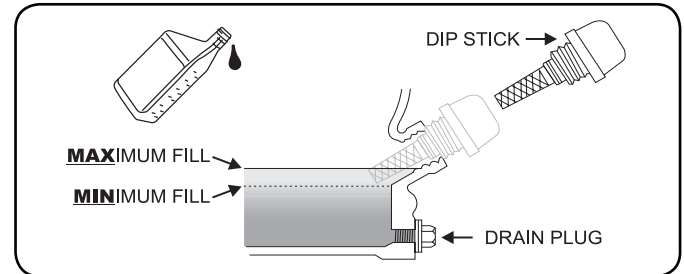

Spark Plugs

1. Remove the spark plug cable from the spark plug.
2. Use the spark plug tool that shipped with your generator to remove the plug.
3. Inspect the electrode on the plug. It must be clean and not worn to produce the spark required for ignition.
4. Make certain the spark plug gap is 0.7 - 0.8mm or (0.028 - 0.031 in.).

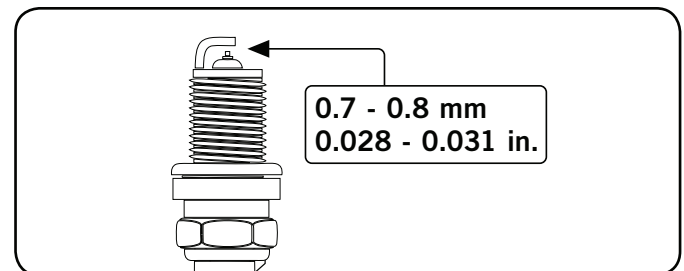

5. Refer to the spark plug recommendation chart when replacing the plug.
6. Carefully thread the plug into the engine.
7. Use the spark plug tool to firmly install the plug.
8. Attach the spark plug wire to the plug.

Air Filter

1. Remove the snap-on cover holding the air filter to the assembly.
2. Remove the foam element.
3. Wash in liquid detergent and water. Squeeze thoroughly dry in a clean cloth.
4. Saturate in clean engine oil.
5. Squeeze in a clean, absorbent cloth to remove all excess oil.
6. Place the filter in the assembly.
7. Reattach the air filter cover and snap in place.

Spark Arrester

1. Allow the engine to cool completely before servicing the spark arrester.
2. Remove the three screws holding the cover plate which retains the end of the spark arrester to the muffler.
3. Remove the spark arrester screen.
4. Carefully remove the carbon deposits from the spark arrester screen with a wire brush.
5. Replace the spark arrester if it is damaged.
6. Position the spark arrester in the muffler and attach with the three screws.

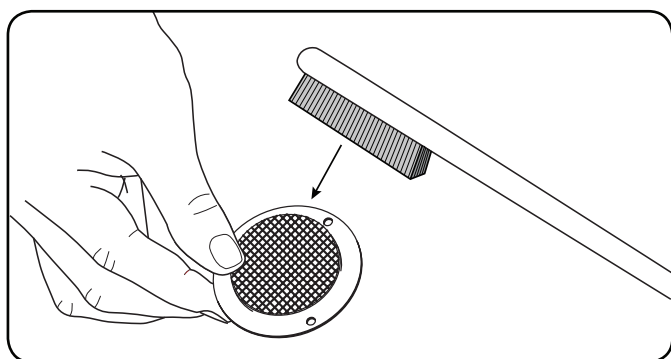

! CAUTION

Failure to clean the spark arrester will result in degraded engine performance.

NOTE

Federal and local laws and administrative requirements indicate when and where spark arresters are required. When ordered, spark arresters are required for operation of this generator in National Forest lands. In California, this generator must not be used on any forest- covered land, brush-covered land, or grass- covered land unless the engine is equipped with a spark arrester.

Cleaning

! CAUTION

DO NOT spray engine with water.

Water can contaminate the fuel system.

Use a damp cloth to clean exterior surfaces of the engine. Use a soft bristle brush to remove dirt and oil. Use an air compressor (25 PSI) to clear dirt and debris from the engine.

Adjustments

The air-fuel mixture is not adjustable. Tampering with the governor can damage your generator and your electrical devices and will void your warranty. CPE recommends that you contact our service line at **1-877-338-0999** for all other service and/or adjustment needs.

Maintenance Schedule

Follow the service intervals indicated in the following maintenance schedule.

Service your generator more frequently when operating in adverse conditions.

Contact our helpline at **1-877-338-0999** to locate the nearest Champion Power Equipment certified service dealer for your generator or engine maintenance needs.

| Every 8 hours or daily | |
|---------------------------------|---|
| | Check oil level |
| | Clean around air intake and muffler |
| First 5 Hours | |
| | Change oil |
| Every 50 hours or every season | |
| | Clean air filter |
| | Change oil if operating under heavy load or in hot environments |
| Every 100 hours or every season | |
| | Change oil |
| | Clean/Adjust spark plug |
| | Check/Adjust valve clearance * |
| | Clean spark arrester |
| | Clean fuel tank and filter * |
| Every 250 hours | |
| | Clean combustion chamber* |
| Every 3 years | |
| | Replace fuel line |

*To be performed by knowledgeable, experienced owners or Champion Power Equipment certified dealers.

MAINTENANCE AND STORAGE

Generator Maintenance

Make certain that the generator is kept clean and stored properly. Only operate the unit on a flat, level surface in a clean, dry operating environment. DO NOT expose the unit to extreme conditions, excessive dust, dirt, moisture or corrosive vapors.

⚠ CAUTION

DO NOT use a garden hose to clean the generator.

Water can enter the generator through the cooling slots and damage the generator windings.

Use a damp cloth to clean exterior surfaces of the generator. Use a soft bristle brush to remove dirt and oil. Use an air compressor (25 PSI) to clear dirt and debris from the generator. Inspect all air vents and cooling slots to ensure that they are clean and unobstructed.

Storage

The generator should be started at least once every 14 days and allowed to run for at least 20 minutes. For longer term storage, please follow these guidelines.

Generator Storage

1. Allow the engine to cool completely before storage.
2. Clean the generator according to the instructions in the Maintenance section.
3. Turn the Fuel Valve to the "OFF" position.
4. Be sure all appliances are disconnected from the generator. Start the engine and let it run until the fuel in the line and the carburetor is consumed and the engine dies.
5. Add a fuel stabilizer into the fuel tank.
6. Change the oil.
7. Remove the spark plug and pour about ½ ounce of oil into the cylinder. Crank the engine slowly to distribute the oil and lubricate the cylinder.
8. Reattach the spark plug.
9. Store the unit in a clean, dry place out of direct sunlight.

Engine Specifications

- Engine 338 cc OHV CPE

Generator Specifications

- Rated Wattage 5500 Watts
- Starting Wattage 6800 Watts
- AC Load 120/240 V
- Phase Single
- Frequency 60 Hz
- Fuel Capacity 5.9 gallons (22.4 L)
- Gross Weight 185.9 lbs (84.5 kg)
- Net Weight 179.3 lbs (81.5 kg)
- Height 26.9 inches (68.2 cm)
- Width 25.8 inches (65.6 cm)
- Length 43.7 inches (111.1 cm)

Fuel

Fuel capacity is 5.9 gallons (22.4 L). Use regular unleaded gasoline with a minimum octane rating of 85 and an ethanol content of less than 10% by volume.

Oil

Use 4-Cycle automotive oil.

Oil capacity is 1.16 qt (1.1 L).

Please reference the following chart for recommended oil types for use in the generator.

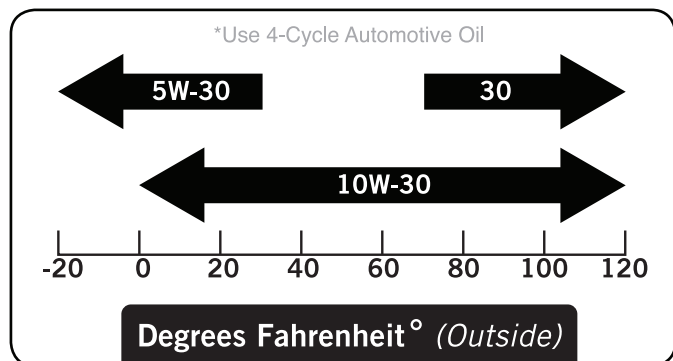

Spark Plugs

Recommended replacement spark plug:

- **NGK BR6ES or equivalent**

Make certain the spark plug gap is 0.7 – 0.8 mm or (0.028 – 0.031 in.).

Valve Clearance

- Intake: 0.13 – 0.17 mm (0.005 – 0.007 in.)
- Exhaust: 0.18 – 0.22 mm (0.007 – 0.009 in.)

SPECIFICATIONS

Parts Diagram

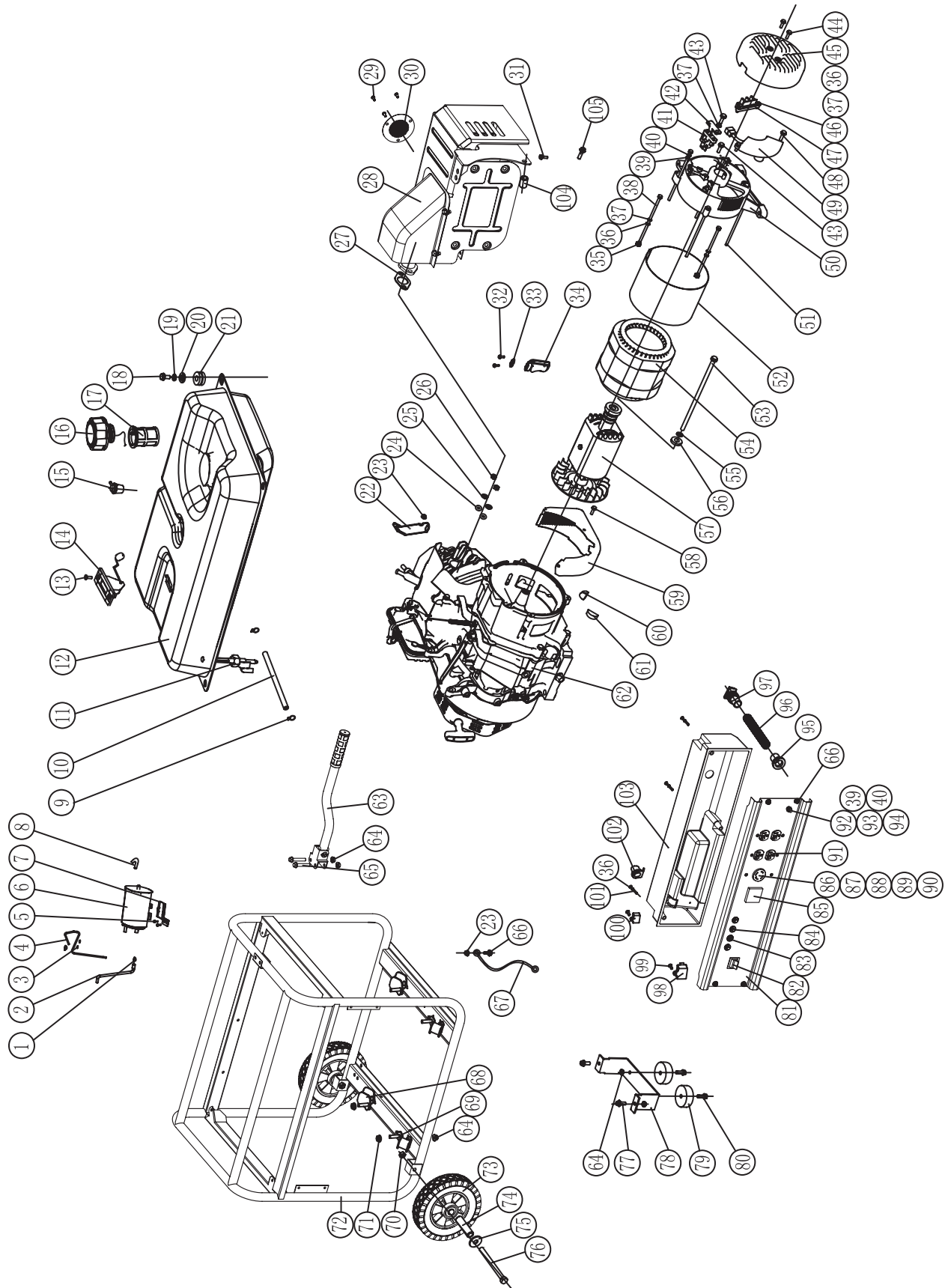

| # | Part Number | Description | Qty |
|----|----------------------|------------------------|-----|
| 1 | ST160F-1070007 | clip | 2 |
| 2 | ST05FD-04712003-CARB | Air cleaner hose | 1 |
| 3 | ST168FD-1070408-CARB | Clip | 2 |
| 4 | 509.070014.00 | rollover valve hose | 1 |
| 5 | GB5789 M8x12 | Flange Bolt M8x12 | 4 |
| 6 | ST05FD-04712100-CARB | canister | 1 |
| 7 | ST05FD-1180011-CARB | charcoal canister | 1 |
| 8 | ST168FD-1160305-CARB | 90o Elbow | 1 |
| 9 | ST188FD-1070006A | Clip | 2 |
| 10 | ST173F-1070001-CPE | Fuel tube(8.9in) | 1 |
| 11 | ST02FD-04160000 | Fuel cock | 1 |
| 12 | 509.071000.35(Y) | Fuel tank | 1 |
| 13 | GB819 M5x10 | Screw M5x10 | 2 |
| 14 | ST05FD-04711200-CARB | Fuel meter assy | 1 |
| 15 | ST168F-1070400-K | rollover valve(KELCH) | 1 |
| 16 | 168.070100.01 | Fuel filler cap assy | 1 |
| 17 | ST168F-1070006A | Fuel filler | 1 |
| 18 | GB5789 M6x20 | Flange Bolt M6x20 | 4 |
| 19 | GB93 6 | Spring waasher 6 | 4 |
| 20 | ST02FD-04100014 | Washer 6 | 4 |
| 21 | ST02FD-04100010 | Tank rubber | 4 |
| 22 | ST188FD-1090006 | Air cleaner stay | 1 |
| 23 | GB6177 M6 | Nut M6 | 2 |
| 24 | GB848 8 | Washer 8 | 2 |
| 25 | GB93 8 | Spring washer 8 | 4 |
| 26 | GB6175 M8 | NutM8 | 2 |
| 27 | ST188FD-1100001-G | Muffler gasket | 1 |
| 28 | 188.101000.05 | muffler | 1 |
| 29 | GB818 M5x12 | ScrewM5x12 | 3 |
| 30 | 188.101500.31 | Spark Arrester Assy | 1 |
| 31 | GB5789 M8x20 | Flange Bolt M8x20 | 1 |
| 32 | GB16674 M6x12 | Flange Bolt M6x12 | 2 |
| 33 | ST168FD-1100003-CARB | air fill clique washer | 1 |
| 34 | ST168FD-1100300-CARB | air fill clique | 1 |
| 35 | GB6175 M5 | Nut M5 | 2 |
| 36 | GB97.1 5 | Washer 5 | 5 |
| 37 | GB93 5 | Spring washer 5 | 5 |
| 38 | ST05FD-1152007-4 | Flange bolt M5x201 | 2 |
| 39 | GB97.1 6 | Washer 6 | 6 |
| 40 | GB93 6 | Spring washer6 | 6 |
| 41 | ST05FD-1152035 | Brush assy | 1 |
| 42 | ST02FD-02100008 | Brush assy cover board | 1 |
| 43 | GB5783 M5x20 | Bolt M5x20 | 1 |
| 44 | GB16674 M5x12 | Flange Bolt M5x12 | 2 |
| 45 | ST05FD-1152001(Y) | Generator end cover | 1 |
| 46 | GB5783 M5x16 | Bolt M5x16 | 2 |
| 47 | ST02FD-02100010 | terminal | 1 |
| 48 | GB16674 M5x16 | Flange Bolt M5x16 | 2 |
| 49 | ST05FD-1152030 | AVR | 1 |
| 50 | ST05FD-1152002 | End cover | 1 |
| 51 | ST05FD-1152004-04 | Flange bolt M6x165 | 4 |
| 52 | ST188FD-1152003-4 | Stator cover | 1 |
| 53 | ST05FD-1152005-4 | Flange bolt M10x250 | 1 |

| # | Part Number | Description | Qty |
|-----|---------------------|-----------------------|-----|
| 54 | ST188FD-1152010-4 | Stator assy | 1 |
| 55 | GB7244 10 | Spring washer 10 | 1 |
| 56 | GB96 10 | Washer 10 | 1 |
| 57 | ST05FD-1152020-4 | Rotor comp | 1 |
| 58 | GB5789 M6x8 | Flange Bolt M6x8 | 2 |
| 59 | ST05FD-1151600 | Cover | 1 |
| 60 | ST05FD-1152008 | Plug-A | 1 |
| 61 | ST05FD-1152009 | Plug-B | 1 |
| 62 | 182FD-GC | 182FD-GC style Engine | 1 |
| 63 | ST182FD-1151110-B | Handle | 1 |
| 64 | GB6177 M8 | Nut M8 | 10 |
| 65 | GB5789 M8x45 | Flange boltM8x45 | 2 |
| 66 | GB5789 M6x12 | Flange Bolt M6x12 | 5 |
| 67 | ST02FD-1152010-5 | Grounding line | 1 |
| 68 | ST05FD-1151400-1 | Bottom rubber 2 | 2 |
| 69 | ST05FD-1151300-1 | Bottom rubber 1 | 2 |
| 70 | GB6182 M10 | Nut M10 | 2 |
| 71 | GB6177 M10 | Nut M10 | 4 |
| 72 | ST05FD-188-4(F) | frame | 1 |
| 73 | ST177FD-1152300(Y) | 8in Wheel | 2 |
| 74 | ST02FD-03621001 | Bush 16x10.5x59 | 2 |
| 75 | GB96 10 | Flat washer 10 | 2 |
| 76 | GB5782 M10x105 | Bolt M10x105 | 2 |
| 77 | GB5789 M8x16 | Flange Bolt M8x16 | 2 |
| 78 | ST05FD-03020301-60 | Support leg(2.36in) | 1 |
| 79 | ST188FD-1743002-C | Vibration mount | 2 |
| 80 | GB5789 M8x25 | Flange Bolt M8x25 | 2 |
| 81 | 5A97(F) | Control panel | 1 |
| 82 | ST05FD-05705001 | Ignition Switch | 1 |
| 83 | ST02FD-05302001-L25 | A.C 25A Breaker | 2 |
| 84 | ST02FD-05302001-L20 | A.C20A Breaker | 2 |
| 85 | ST02FD-05602010-D | Volt Meter | 1 |
| 86 | ST02FD-05502022 | Receptacle L14-30R | 1 |
| 87 | GB823 M4x14 | Screw M4x14 | 6 |
| 88 | GB859 4 | Spring washer 4 | 6 |
| 89 | GB848 4 | Flat washer 4 | 6 |
| 90 | GB6177 M4 | Nut M4 | 6 |
| 91 | ST02FD-05502023 | Receptacle 5-20R | 2 |
| 92 | GB5783 M6x22 | Bolt M6x22 | 1 |
| 93 | GB6175 M6 | Nut M6 | 2 |
| 94 | GB862 6 | washer 6 | 1 |
| 95 | ST05FD-05215001 | Build up | 1 |
| 96 | ST05FD-05215009 | conduit | 1 |
| 97 | ST05FD-05215003 | Build up | 1 |
| 98 | BG01-00000000 | manostat | 1 |
| 99 | GB823 M5x14 | ScrewM5x14 | 1 |
| 100 | OV01-00000000 | Transition | 1 |
| 101 | GB818 M5x38 | Screw M5x38 | 3 |
| 102 | ST05FD-05215006 | Assistant Build up | 1 |
| 103 | ST05FD-05205009 | Panel Back Cover | 1 |
| 104 | ST188FD-1730003 | Bush 13x9x16 | 1 |
| 105 | GB5789 M8x35 | Flange Bolt M8x35 | 1 |

SPECIFICATIONS

Engine Parts Diagram

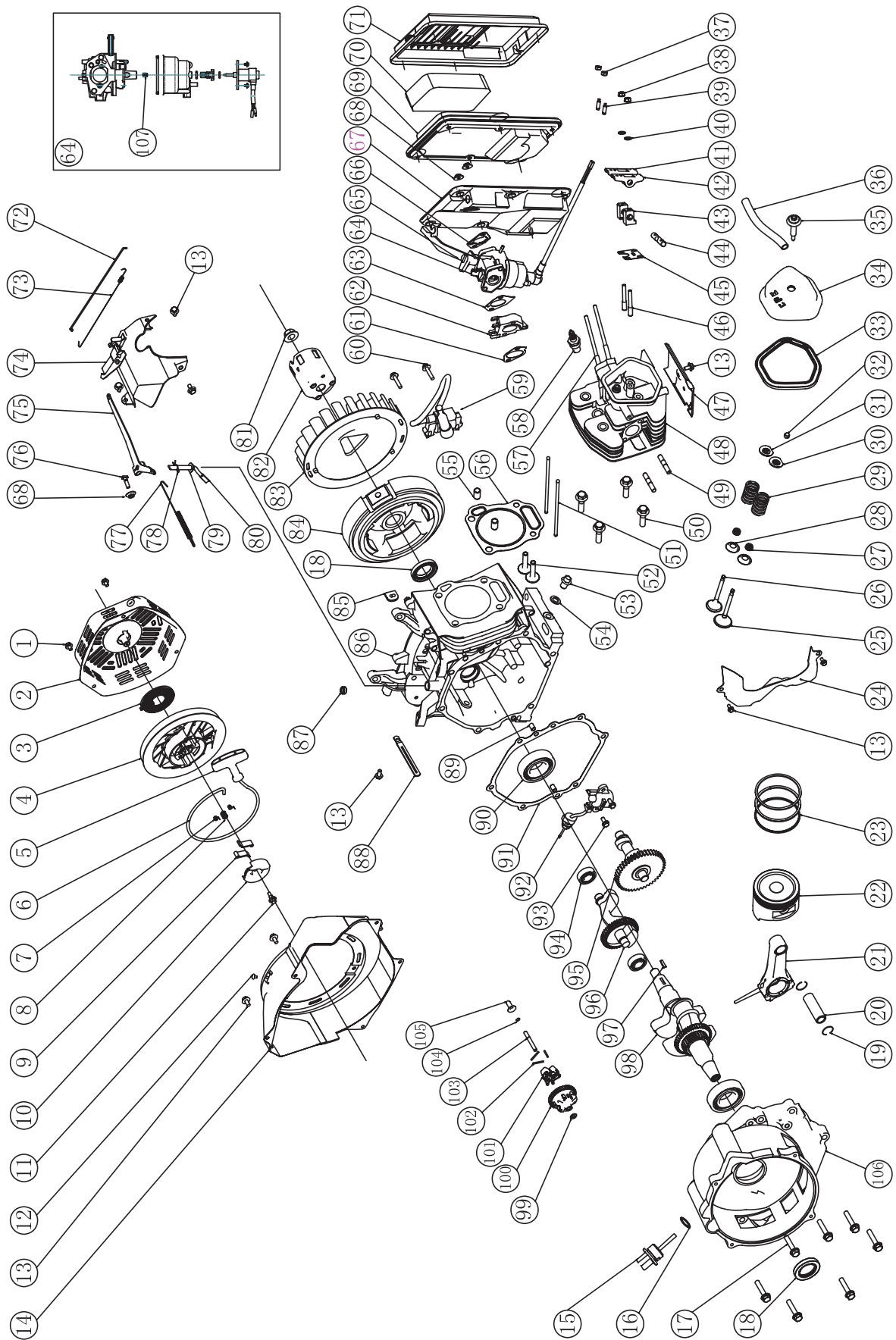

| # | Part Number | Description | Qty |
|----|--------------------|------------------------------|-----|
| 1 | GB5789--86-FB6-8 | Flange bolt M6*8 | 3 |
| 2 | ST188F-1060100-G | Recoil starter case comp | 1 |
| 3 | ST188F-1060009 | Starter return spring | 1 |
| 4 | ST188F-1060008 | Recoil starter pulley | 1 |
| 5 | ST160F-1061200 | Recoil starter knob | 1 |
| 6 | ST188F-1060007 | Recoil starter rope | 1 |
| 7 | ST188F-1060006 | Ratchet spring | 2 |
| 8 | ST188F-1060004 | Ratchet guide spring | 1 |
| 9 | ST188F-1060005 | Ratchet starter | 2 |
| 10 | ST188F-1060003 | Ratchet guide | 1 |
| 11 | ST188F-1060002 | Ratchet guide bolt | 1 |
| 12 | ST188FD-1130004 | Wire clip | 2 |
| 13 | GB5789--86-FB6-12 | Flange bolt M6*12 | 12 |
| 14 | ST188FD-1081000-G | Fan corer comp | 1 |
| 15 | ST188FD-1030003-A | Oil filler cap assembly | 1 |
| 16 | ST188FD-1030014 | Oil filler cap packing | 1 |
| 17 | GB5789-86-FB8-40 | Flange boltM8*40 | 7 |
| 18 | ST188F-1030200 | Oil seal | 2 |
| 19 | ST188F-1050004 | Piston pin clip | 2 |
| 20 | ST188F-1050005 | Piston pin | 1 |
| 21 | ST188F-1050200 | Connecting rod assembly | 1 |
| 22 | ST182F-1050001 | Piston | 1 |
| 23 | ST182F-1050100 | Oil seal set comp | 1 |
| | ST182F-1050003 | Second ring set | 1 |
| | ST182F-1050002 | First ring set | 1 |
| 24 | ST188F-1080002-G | Shroud | 1 |
| 25 | ST188F-1040011 | EX, Valve | 1 |
| 26 | ST188F-1040003 | IN, valve | 1 |
| 27 | ST188F-1040004 | Valve oil | 2 |
| 28 | ST188F-1040006 | Valve spring washer | 2 |
| 29 | ST188F-1040007 | Valve spring | 2 |
| 30 | ST188F-1040008 | Ex, valve spring retainer | 1 |
| 31 | ST188F-1040002 | IN, valve spring retainer | 1 |
| 32 | ST188F-1040009 | Valve rotator | 1 |
| 33 | ST188F-1020003-CPE | Head over packing | 1 |
| 34 | ST188F-1020100-A | Head cover comp | 1 |
| 35 | ST188F-1020006 | Head cover bolt comp | 1 |
| 36 | ST188FD-1020002 | Tube | 1 |
| 37 | ST160F-1040025 | Pivot adjusting nut | 2 |
| 38 | GB6177--86-N6 | Nut M6 | 2 |
| 39 | ST160F-1040024 | Rocker arm Bolt | 2 |
| 40 | GB97.1-85 | Washer 6 | 2 |
| 41 | ST188F-1040022 | Intake valve exhaust rocker | 1 |
| 42 | ST188F-1040023 | Exhaust valve exhaust rocker | 1 |
| 43 | ST188F-1040026 | Valve rocker arm | 1 |
| 44 | ST188F-1040021 | Rocker axes | 1 |
| 45 | ST188F-1040028 | Push rod guide plate | 1 |
| 46 | ST168F--1040027 | Pivot bolt | 2 |
| 47 | ST188F-1080001-G | Shroud | 1 |
| 48 | ST188F-1011000-G | Head comp | 1 |
| 49 | ST188F-1010001 | Bolt | 2 |
| 50 | ST188F-1030009 | Bolt | 4 |
| 51 | ST188F-1040010-II | Push rod | 2 |
| 52 | ST188F-1040012 | Valve lifter | 2 |
| 53 | 139FMD-1003101 | Drain plug bolt | 2 |
| 54 | 139FMD-1003102 | Drain plug washer | 2 |
| 55 | ST188F-1030013 | Dowel pin | 2 |

| # | Part Number | Description | Qty |
|-----|----------------------|------------------------------|-----|
| 56 | ST182F-1030008-G | Cylinder head casket | 1 |
| 57 | ST188FD-1010002 | Bolt | 2 |
| 58 | NHSP LD F6TC | Spark plug | 1 |
| 59 | ST188F-1122000-G | Ignition | 1 |
| 60 | GB5789--86-FB6-29 | Flange bolt 6*29 | 2 |
| 61 | ST188FD-1130003-CPE | Carburetor insulator packing | 1 |
| 62 | ST182F-1134000 | Carburetor insulator | 1 |
| 63 | ST182F-1130002-CPE | Carburetor packing | 1 |
| 64 | ST182FD-1133000-A | Carburetor assy | 1 |
| 65 | ST188FD-1130100-C | Choke lever comp | 1 |
| 66 | ST188FD-1130001-CPE | Carburetor packing | 1 |
| 67 | ST188FD-1090100-CARB | Air cleaner case comp | 1 |
| 68 | GB6177--86-N6 | Nut M6 | 3 |
| 69 | ST188FD-1090003 | Separator | 1 |
| 70 | ST188FD-1090004 | Element | 1 |
| 71 | ST188FD-1090200-G | Air cleaner cover comp | 1 |
| 72 | ST188F-1110002 | Governor rod | 1 |
| 73 | ST188F-1110001 | Throttle return spring | 1 |
| 74 | ST188FD-1081000-G | Control assy | 1 |
| 75 | ST188F-1110006 | Governor arm | 1 |
| 76 | ST160F-1110004 | Governor arm bolt | 1 |
| 77 | ST188F-1110004 | Governor spring | 1 |
| 78 | ST188F-1110007 | Pin clip | 2 |
| 79 | ST188F-1110005 | Washer8.2x17x0.8 | 1 |
| 80 | ST188F-1110003 | Cover arm shaft | 1 |
| 81 | ST188F-1050006 | Special nut | 1 |
| 82 | ST188F-1060001 | Starter pulley comp | 1 |
| 83 | ST188F-1080002 | Cooling fan | 1 |
| 84 | ST188F-1121000 | Flywheel comp | 1 |
| 85 | ST188F-1030012 | Packing | 1 |
| 86 | ST182F-1030006-G | Crankcase assy | 1 |
| 87 | ST188F-1030100 | Oil seal | 1 |
| 88 | ST188F-1030001 | Wire clip | 1 |
| 89 | ST168F-1030015-G | Dowel pin 9*14 | 2 |
| 90 | GB/T276-94 6207/C3 | Radial ball bearing 6207/C3 | 2 |
| 91 | ST188F-1030010-G | Case cover packing | 1 |
| 92 | ST188FD-1127000-A | Oil level switch assy | 1 |
| 93 | GB5789--86-FB6-15 | Flange bolt M6*15 | 2 |
| 94 | GB/T276-94 | Radial ball bearing6202/P6 | 2 |
| 95 | ST188F-1041000 | Camshaft comp | 1 |
| 96 | ST188F-1050303 | Balance gear | 1 |
| 97 | ST188F-1050304 | Key | 1 |
| 98 | ST188F-1050300-A | Crankshaft comp | 1 |
| 99 | ST160F-1110108 | Washer | 1 |
| 100 | ST188F-1110101 | Governor weight holder | 1 |
| 101 | ST188F-1110103 | Governor weight | 3 |
| 102 | ST188F-1110102 | Governor weight pin | 3 |
| 103 | ST188F-1110009 | Governor shaft | 1 |
| 104 | ST160F-1110103 | Governor shaft clip | 1 |
| 105 | ST188F-1110008 | Governor slider | 1 |
| 106 | ST188FD-1031011-G | Crankcase Cover | 1 |
| 107 | ST182FD-1131000-17 | METERING JET,MAIN | 1 |

SPECIFICATIONS

Wiring Diagram

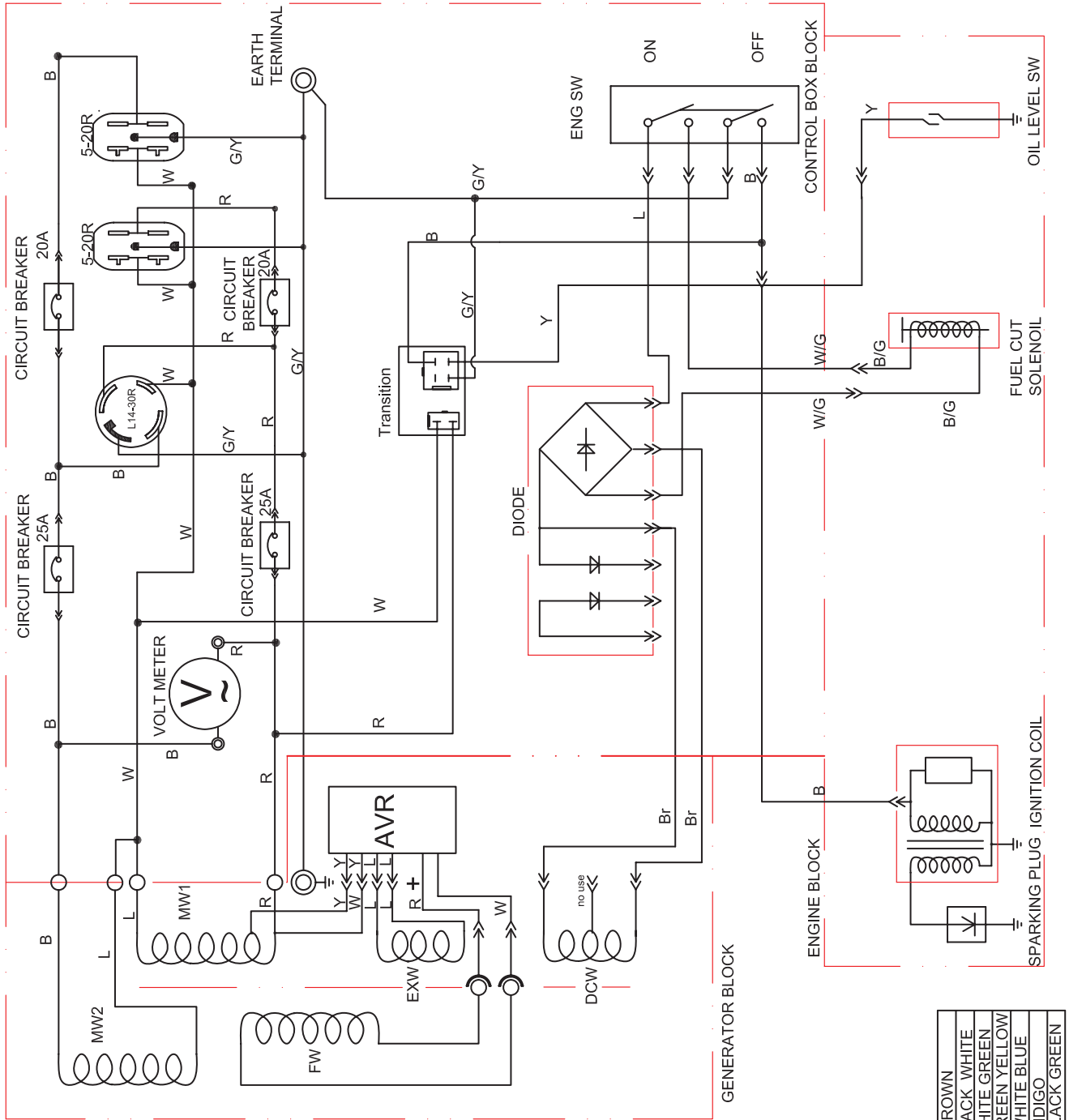

| | | | |
|---|--------|-----|--------------|
| B | BLACK | Br | BROWN |
| Y | YELLOW | B/W | BLACK WHITE |
| L | BLUE | W/G | WHITE GREEN |
| G | GREEN | GY | GREEN YELLOW |
| R | RED | W/L | WHITE BLUE |
| W | WHITE | In | INDIGO |
| | | B/G | BLACK GREEN |

| Problem | Cause | Solution |
|---|-------------------------------------|--|
| Generator will not start | No fuel | Add fuel |
| | Faulty spark plug | Replace spark plug |
| | Unit loaded during start up | Remove load from unit |
| Generator will not start; | Low oil level | Fill crankcase to the proper level |
| | | Place generator on a flat, level surface |
| Generator starts but runs roughly | Choke in the wrong position. | Adjust choke. |
| | Spark plug wire loose | Attach wire to spark plug |
| Generator shuts down during operation | Out of fuel | Fill fuel tank |
| | Low oil level | Fill crankcase to the proper level. Place generator on a flat, level surface |
| Generator cannot supply enough power or overheating | Generator is overloaded | Review load and adjust. See "Power Management" |
| | Insufficient ventilation | Check for air restriction. Move to a well ventilated area |
| No AC output | Cable not properly connected | Check all connections |
| | Connected device is defective | Replace defective device |
| | Circuit breaker is open | Reset circuit breaker |
| | Faulty brush assembly | Replace brush assembly (Service Center) |
| | Faulty AVR (auto voltage regulator) | Replace AVR (Service Center) |
| | Loose wiring | Inspect and tighten wiring connections |
| | Other | Contact the help line. |
| Generator gallops | Engine governor defective | Contact the help line |
| Repeated circuit breaker tripping | Overload | Review load and adjust. See "Power Management" |
| | Faulty cords or device | Check for damaged, bare or frayed wires. Replace defective device |

For further technical support:

Technical Service

Mon – Fri 8:30 AM – 5:00 PM (PST/PDT)

Toll Free: 1-877-338-0999

tech@championpowerequipment.com

WARRANTY

WARRANTY

CHAMPION POWER EQUIPMENT
2 YEAR LIMITED WARRANTY

Warranty Qualifications

Champion Power Equipment (CPE) will register this warranty upon receipt of your Warranty Registration Card and a copy of your sales receipt from one of CPE's retail locations as proof of purchase.

Please submit your warranty registration and your proof of purchase within ten (10) days of the date of purchase.

Repair/Replacement Warranty

CPE warrants to the original purchaser that the mechanical and electrical components will be free of defects in material and workmanship for a period of one year (parts and labor) and two years (parts) from the original date of purchase (90 days (parts and labor) and 180 days (parts) for commercial & industrial use). Transportation charges on product submitted for repair or replacement under this warranty are the sole responsibility of the purchaser. This warranty only applies to the original purchaser and is not transferable.

Do Not Return The Unit To The Place Of Purchase

Contact CPE's Technical Service and CPE will troubleshoot any issue via phone or e-mail. If the problem is not corrected by this method, CPE will, at its option, authorize evaluation, repair or replacement of the defective part or component at a CPE Service Center. CPE will provide you with a case number for warranty service. Please keep it for future reference. Repairs or replacements without prior authorization, or at an unauthorized repair facility, will not be covered by this warranty.

Warranty Exclusions

This warranty does not cover the following repairs and equipment:

Normal Wear

Generators need periodic parts and service to perform well. This warranty does not cover repair when normal use has exhausted the life of a part or the equipment as a whole.

Installation, Use and Maintenance

This warranty will not apply to parts and/or labor if this generator is deemed to have been misused, neglected, involved in an accident, abused, loaded beyond the generator's limits, modified, installed improperly or connected incorrectly to any electrical component.

Installation, Use and Maintenance Cont'd.

Normal maintenance such as spark plugs, air filters, adjustments, fuel system cleaning and obstruction due to buildup is not covered by this warranty.

Other Exclusions

This warranty excludes:

- Cosmetic defects such as paint, decals, etc.
- Wear items such as filter elements, o-rings, etc.
- Accessory parts such as starting batteries, and storage covers.
- Failures due to acts of God and other force majeure events beyond the manufacturer's control.
- Problems caused by parts that are not original Champion Power Equipment parts.

This warranty does not apply to generators used for prime power in place of a utility.

Limits of Implied Warranty and Consequential Damage

Champion Power Equipment disclaims any obligation to cover any loss of time, use of this product, freight, or any incidental or consequential claim by anyone from using this generator. THIS WARRANTY IS IN LIEU OF ALL OTHER WARRANTIES, EXPRESS OR IMPLIED, INCLUDING WARRANTIES OF MERCHANTABILITY OR FITNESS FOR A PARTICULAR PURPOSE.

A unit provided as an exchange will be subject to the warranty of the original unit. The length of the warranty governing the exchanged unit will remain calculated by reference to the purchase date of the original unit.

This warranty gives you certain legal rights which may change from state to state. Your state may also have other rights you may be entitled to that are not listed within this warranty.

Contact Information

Address

Champion Power Equipment, Inc.
Customer Service
10006 Santa Fe Springs Rd.
Santa Fe Springs, CA 90670
www.championpowerequipment.com

Customer Service

Mon – Fri 8:30 AM – 5:00 PM (PST/PDT)
Toll Free: 1-877-338-0999
info@championpowerequipment.com
Fax no.: 1 (562) 236-9429

Technical Service

Mon – Fri 8:30 AM – 5:00 PM (PST/PDT)
Toll Free: 1-877-338-0999
tech@championpowerequipment.com
24/7 Tech Support: (562) 204-1188