

BI605BFF

34.38" x 23.63" x 25.0" (H x W x D)

Built-in undercounter refrigerator-freezer with digital thermostat and automatic defrost, in black exterior

Highlights:

Flexible design allows built-in or freestanding use

Perfectly sized to fit under counters and in 24 inch spaces, with a generous 6 c.f. of interior capacity

Automatic defrost operation minimizes user maintenance in both refrigerator and freezer sections

Digital thermostat provides precise temperature control



Slim undercounter dimensions

Less than 24 inches wide, with a generous 6 c.f. of interior capacity

Built-in capable

Make the best use of space by installing your appliance under the counter and flush with other cabinetry

Fully finished black cabinet

Allows the unit to be used freestanding

Automatic defrost

Simplify maintenance by letting the appliance defrost itself

Adjustable shelves

Rearrange the refrigerator space to fit any sized item or remove shelves for simple cleanup

Door shelves

Store large bottles right on the door for easy access

Digital thermostat

Precise temperature management at the touch of a button

Interior light

Automatically illuminates when the door is opened

100% CFC free

Environmentally friendly design does not contain ozone-damaging chemicals

Specifications:

Height	34.38"
Width	23.63"
Depth	25.0"
Capacity	6.0 cu.ft.
Ext Depth with Handle	25.75"
Interior Height 1	20.25"
Interior Width 1	21.0"
Interior Depth 1	20.5"
Interior Height 2	5.0"
Interior Width 2	21.0"
Interior Depth 2	20.5"
Shipping Weight	120.0 lbs.
Weight	130.0 lbs.
Amps	0.9
US Electrical Safety	UL
Energy Usage/Year	342.0 kWh/year
Voltage/Frequency	115 V AC/60 Hz
Reversible	Yes
Door Swing	RHD
Shelf Quantity	3
Adjustable Shelf	true
Shelf Type	Wire
Full Door Shelf Quantity	3
Defrost Type	Automatic
Depth with door at 90°	47.0"
Height to Hinge Cap	34.75"
Condensor Location	Rear of Unit
Light	true
Fan Type	Exterior
Thermostat Type	Digital
Freon Type	R134a
High Side PSI	235.0
Level Legs Quantity	4
Freon Oz	3.0
Low Side PSI	140.0
Parts/Labor Warranty	1 Year
Compressor Warranty	5 Years

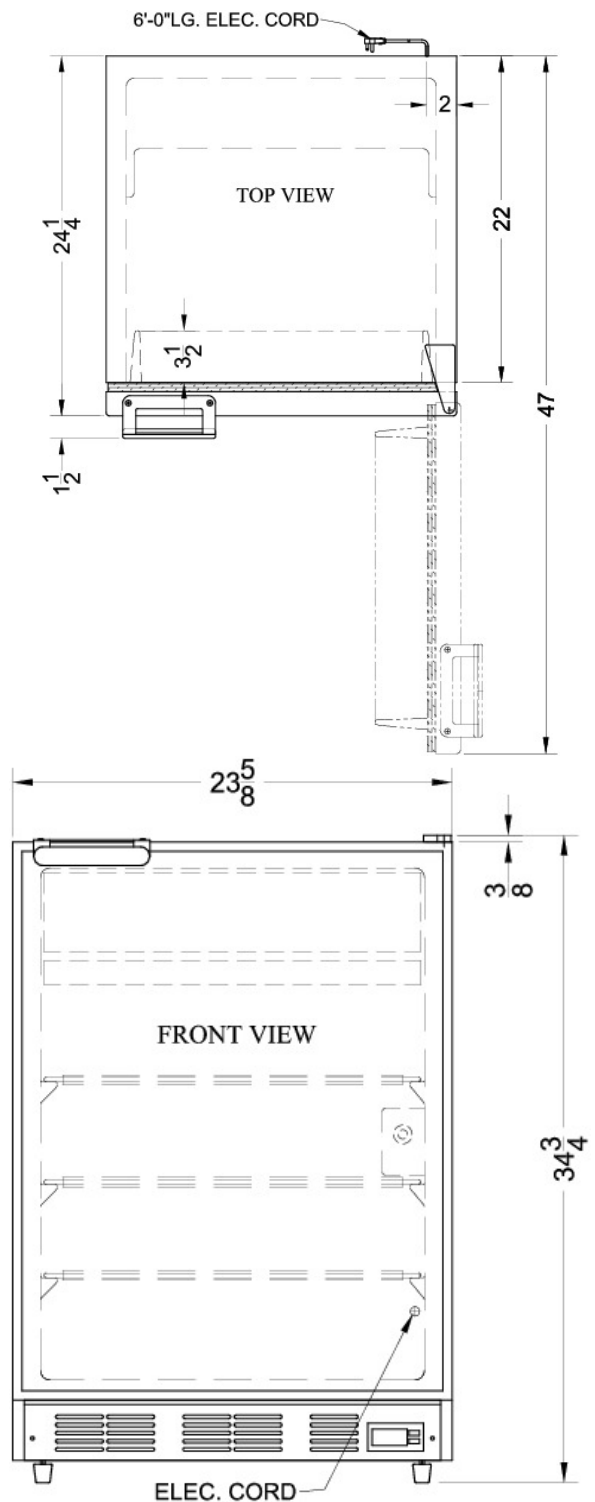

Summit Appliance Division, Felix Storch, Inc.
 770 Garrison Ave • Bronx, NY 10474
 Phone: 718-893-3900 • Fax: 718-842-3093
 Email: info@summitappliance.com