

AL650

32.0" x 23.63" x 23.5" (H x W x D)

ADA compliant refrigerator-freezer for freestanding use, with white exterior and cycle defrost

Highlights:

- Ice cream stays frozen in zero degree freezer
- Cycle defrost system saves both you and your appliance energy
- 32 inch height for lower ADA counters
- Deluxe interior is fully featured for storage convenience



Cycle defrost	Combines an automatic defrosting refrigerator with a manual defrosting freezer to save energy but protect food
ADA compliant	32 inch height fits under standard ADA counters
Fully finished white cabinet	Allows the unit to be used freestanding
Zero degree freezer	Keep ice cream frozen and freezer burn-free in a freezer that reaches and maintains zero degrees
Dual evaporator	SUMMIT's unique and efficient design separately cools the refrigerator while maintaining zero degrees in the freezer with two evaporators
Reversible door	Keep your options flexible with a reversible door that is easy to switch when your arrangement changes
Adjustable shelves	Rearrange your refrigerator space to accommodate all shapes and sizes or remove shelves for a simple clean-up
Door storage	Store large bottles right on the door for easy access
Clear crispener	Get the longest life and best taste out of produce by storing in a convenient slide drawer
Interior light	Automatically illuminates when you open the door

Specifications:

Height	32.0"
Width	23.63"
Depth	23.5"
Capacity	5.1 cu.ft.
Ext Depth with Handle	24.25"
Interior Height 1	19.5"
Interior Width 1	20.5"
Interior Depth 1	17.0"
Interior Height 2	5.0"
Interior Width 2	19.0"
Interior Depth 2	11.5"
Comp Step Height	7.0"
Comp Step Width	20.5"
Comp Step Depth	5.0"
Shipping Weight	102.0 lbs.
Weight	100.0 lbs.
US Electrical Safety	UL
Amps	1.3
Canadian Electrical Safety	ULC
Voltage/Frequency	115 V AC/60 Hz
Energy Usage/Year	434.0 kWh/year
Reversible	Yes
Door Swing	RHD
Crisper Quantity	1
Shelf Quantity	3
Adjustable Shelf	true
Shelf Type	Wire
Crisper Cover Type	Glass
Crisper Finish	Transparent
Full Door Shelf Quantity	3
Defrost Type	Cycle
Depth with door at 90°	45.13"
Height to Hinge Cap	32.25"
Condensor Location	Rear of Unit
Thermostat Type	Dial
Freon Type	R134a
High Side PSI	285.0
Level Legs Quantity	2
Low Side PSI	70.0
Freon Oz	2.6
Parts/Labor Warranty	1 Year
Compressor Warranty	5 Years

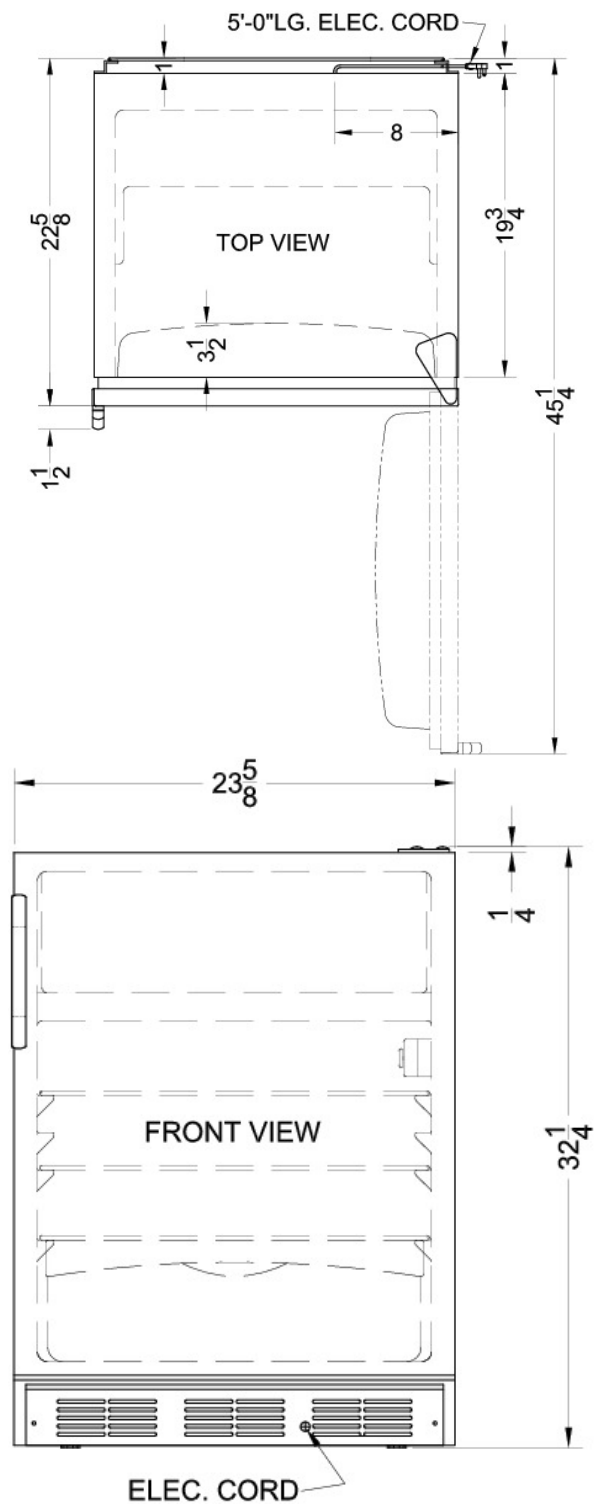

Summit Appliance Division, Felix Storch, Inc.
 770 Garrison Ave • Bronx, NY 10474
 Phone: 718-893-3900 • Fax: 718-842-3093
 Email: info@summitappliance.com