

OWNER'S MANUAL

IRONMAN[®]

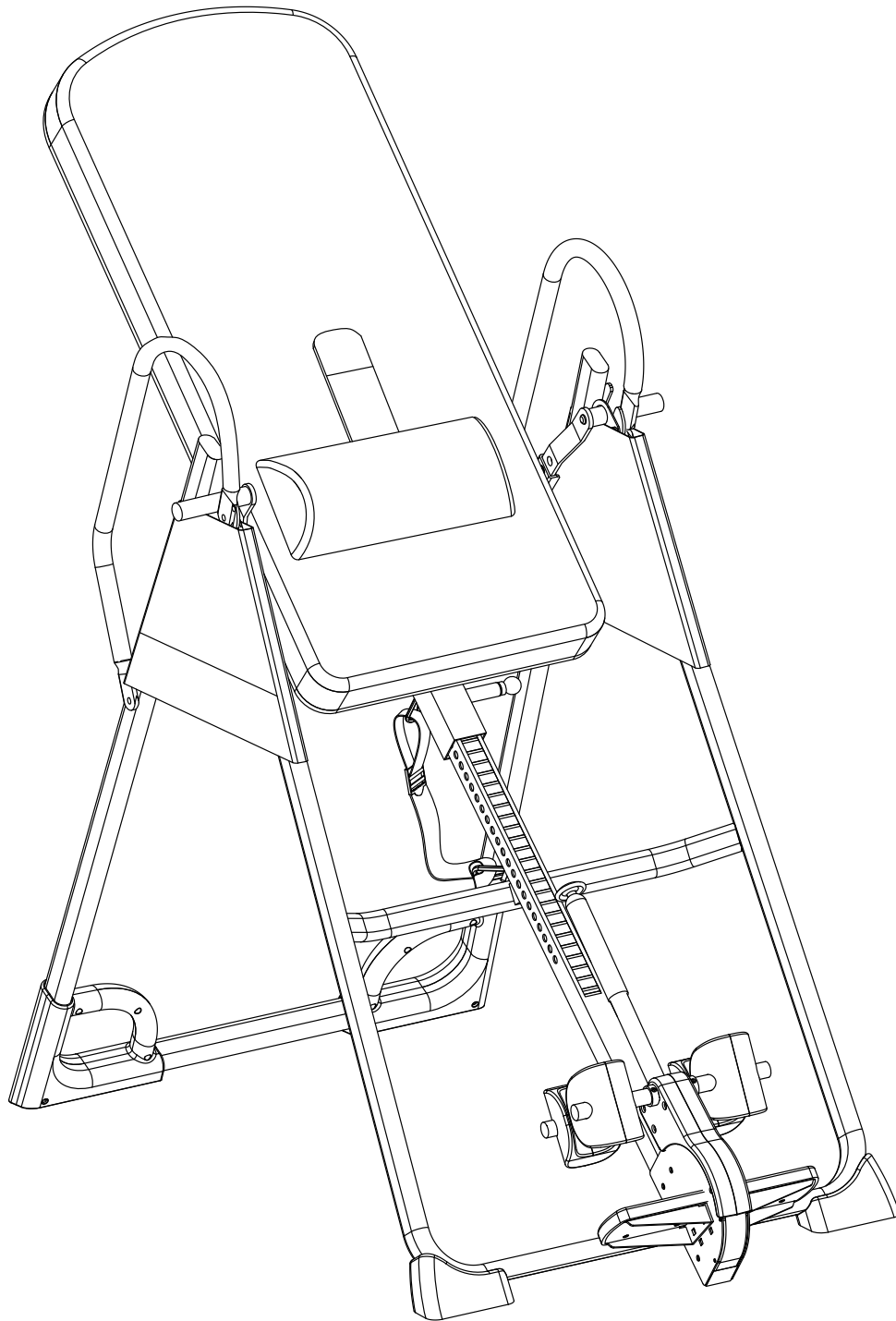

Model 5402 NEW

The specifications of this product may vary from this photo and are subject to change without notice. IRONMAN, IRONMAN TRIATHLON and M-DOT are registered trademarks of World Triathlon Corporation. This product is licensed by the IRONMAN TRIATHLON.

SERVICE

To request for product service and order replacement parts, please call our customer service department at

1-866-924-1688

Monday through Friday, 8:00 am-5:00 pm Pacific Standard Time,
or email at: **service@paradigmhw.com**

Please have the following information ready when requesting for service:

Your name
Phone number
Owner's manual
Model number
Serial number
Part number
Date of purchase

***If the product has major defects which prevent it from functioning properly, please return it to the store of purchase within the period allowed by the store.**

Paradigm Health & Wellness, Inc.
1189 Jellick Ave.
City of Industry, CA 91748

PART REQUEST FAX FORM

Fax this form to 1-626-810-2166

Or email customer service requests to : service@paradigmhw.com

NAME: _____

ADDRESS: _____

TELEPHONE: (day) _____

(night) _____

(fax) _____

MODEL #: _____

PURCHASE DATE: _____

PLACE OF PURCHASE: _____

| Part # | Description | Quan. |
|--------|-------------|-------|
| | | |
| | | |
| | | |
| | | |
| | | |
| | | |
| | | |
| | | |
| | | |
| | | |
| | | |
| | | |
| | | |
| | | |
| | | |
| | | |
| | | |
| | | |
| | | |
| | | |

* YOUR ORDER WILL BE PROCESSED WITHIN 3 BUSINESS DAYS

OFFICIAL USE ONLY

SHIP DATE: _____

TRK # : _____

BACK ORDER: _____

TABLE OF CONTENTS

| | <i>Page #</i> |
|-----------------------------|---------------|
| Service | 2 |
| <hr/> | |
| Part fax request form | 3 |
| <hr/> | |
| Safety precautions | 5 |
| <hr/> | |
| Overview drawing | 6 |
| <hr/> | |
| Part list | 7 |
| <hr/> | |
| Included hardware & tools | 8 |
| <hr/> | |
| Assembly | 9 |
| <hr/> | |
| How to use | 13 |
| <hr/> | |
| Storage | 16 |
| <hr/> | |
| Maintenance instructions | 17 |
| <hr/> | |
| Placement of warning labels | 18 |
| <hr/> | |
| Warm-up | 19 |
| <hr/> | |
| Warranty | 20 |
| <hr/> | |
| Trouble Shooting Section | 21 |

SAFETY PRECAUTIONS

This inversion table was designed and built for optimum safety. However, certain precautions apply whenever you operate the exercise equipment. Be sure to read the entire manual before assembling and operating this equipment. Also, please note the following safety instructions:

1. Consult your physician or other health care professionals before using the inversion table.
2. Always wear proper exercise apparel when using the equipment.
3. If any time you feel faint, light-headed or dizziness while operating the equipment, stop exercise immediately. You should also stop exercising if you are experiencing pain or pressure.
4. Keep children and pets away from the equipment while in use.
5. Only one person should use the equipment at a time.
6. Make sure your equipment is correctly assembled before you use it. Be sure all screws, nuts, and bolts are tightened prior to use.
7. Do not operate this or any exercise equipment if it is damaged.
8. Watch your body: come up slowly, dizziness after a session means you came up too fast. Wait a while after eating before using the inversion table. If you get nauseous, come up as soon as you feel queasy.
9. Always use this equipment on a clear and level surface. Do not use outdoors or near water.
10. Keep hands and feet away from any moving parts. Do not insert any object into any openings.
11. Keep loose clothes, jewelry away from moving parts.
12. **WARNING: ALWAYS HOLD ON TO THE SAFETY HANDLES AND GO BACK SLOWLY WHEN GETTING UP. FAILURE TO COMPLY COULD RESULT IN SERIOUS BODILY INJURY.**
13. Children under the age of 12 should not use the following fitness equipment.

WARNING:

You should consult with your personal physician to see if inversion equipment is appropriate for you. This is especially important for people with pre-existing health problems. Do not use this equipment without your physician's approval.

Do not use this equipment if you have any of the following conditions or ailments:

- . Extreme obesity
- . Glaucoma, retinal detachment or conjunctivitis
- . Pregnancy
- . Spinal injury, Cerebral Sclerosis, or acutely swollen joints
- . Middle ear infection
- . High blood pressure, Hypertension, Recent stroke or Transient Ischemic attack
- . Heart or circulatory disorders for which you are being treated
- . Hiatus hernia or Ventral hernia
- . Bone weaknesses including Osteoporosis, Unhealed fractures, Modularly pins, or Surgically implanted orthopedic supports.
- . Use of anti-coagulants including Aspirin in high doses.

Maximum Weight Capacity is 350 lbs/ 159 kgs.

OVERVIEW DRAWING

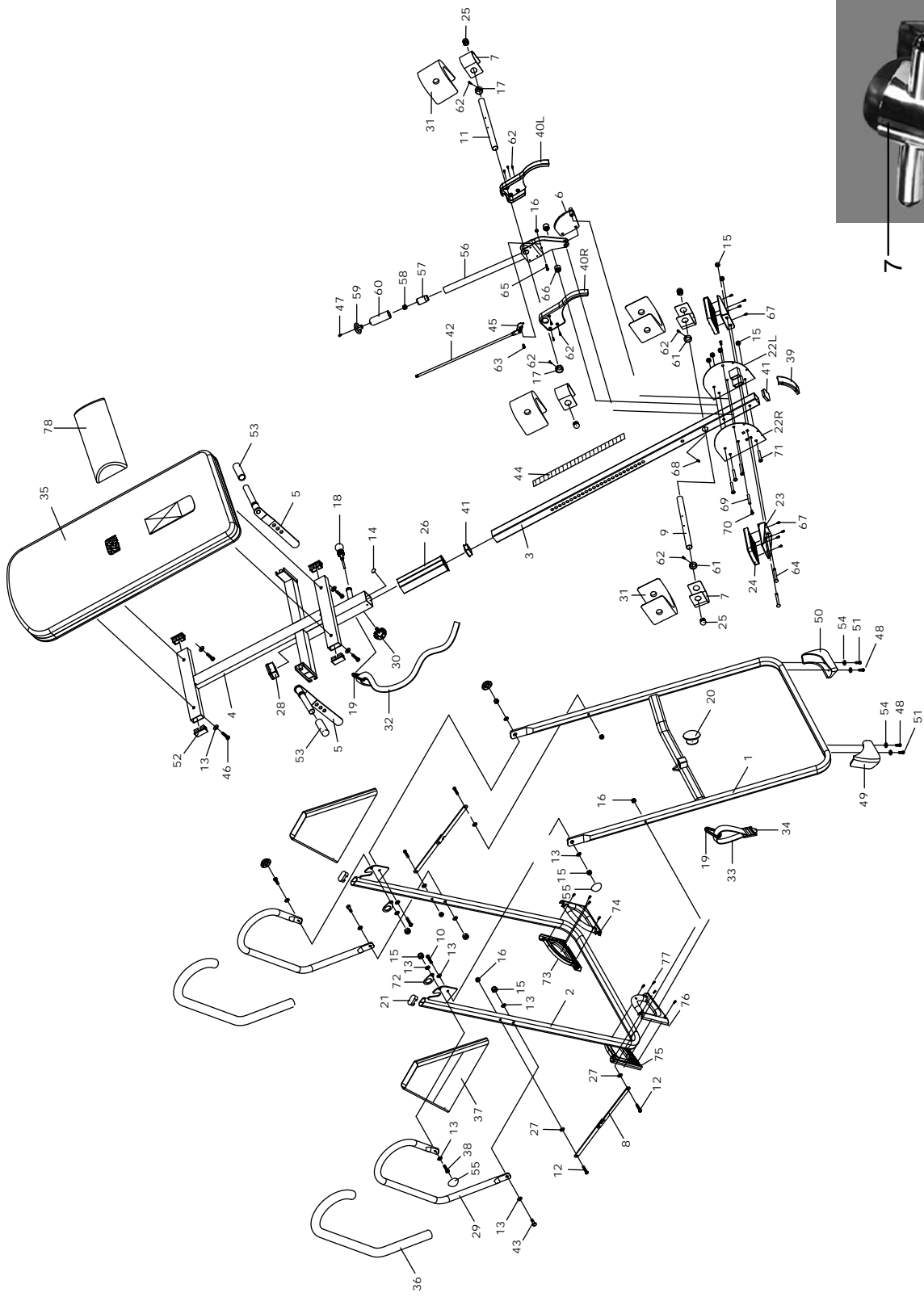

7
31







PART LIST

| Part # | Description | Quan. | Part # | Description | Quan. |
|--------|-------------------------------|-------|--------|------------------------------------|-------|
| 1 | Front U-Frame | 1 | 37 | Protective Cover | 2 |
| 2 | Rear U-Frame | 1 | 38 | Hex Head Bolt M8*23 | 2 |
| 3 | Adjustable Boom | 1 | 39 | Front Plastic Cover | 1 |
| 4 | Bed Frame | 1 | 40L | Left Plastic Cover | 1 |
| 5 | Pivot Arm | 2 | 40R | Right Plastic Cover | 1 |
| 6 | Adjustable Lock Plate | 1 | 41 | Square End Cap | 2 |
| 7 | Steel Heel Holder Bracket | 4 | 42 | Locking Pin | 1 |
| 8 | Folding Arm | 2 | 43 | Hex Head Bolt M8*43 | 2 |
| 9 | Rear Rod | 1 | 44 | Height Scale | 1 |
| 10 | Bolt M8*23 | 2 | 45 | Latch | 1 |
| 11 | Front Rod | 1 | 46 | Foam Bed Bolt | 4 |
| 12 | Phillips Screw M6*35 | 4 | 47 | Bolt M4*25 | 1 |
| 13 | Washer Ø20*Ø8.5*1.5 | 16 | 48 | Bolt M6*20 | 2 |
| 14 | Round Plate | 1 | 49 | Front Right Foot Cap | 1 |
| 15 | Lock Nut M8 | 12 | 50 | Front Left Foot Cap | 1 |
| 16 | Lock Nut M6 | 5 | 51 | Bolt M6*25 | 2 |
| 17 | Blocking Bush Ø28.5 *Ø23 * 14 | 2 | 52 | End Cap (□25*50mm) | 4 |
| 18 | Large Spring Knob | 1 | 53 | Foam Grip | 2 |
| 19 | Safety Hook | 2 | 54 | Washer Ø13*Ø6.5*1.0 | 4 |
| 20 | Rubber Pad | 1 | 55 | Nut Cap Ø27*Ø13.5 | 4 |
| 21 | Oval End Cap | 2 | 56 | Adjustable Handle | 1 |
| 22L | Left Adjustable Boom Plate | 1 | 57 | Handle Cap | 1 |
| 22R | Right Adjustable Boom Plate | 1 | 58 | Handle Spring | 1 |
| 23 | In-Step Frame | 2 | 59 | Button | 1 |
| 24 | In-Step Foot Pad | 2 | 60 | Handle Tip | 1 |
| 25 | Round End Cap | 4 | 61 | Blocking Bush Ø28.5 *Ø22.5 * 10 | 2 |
| 26 | Lower Bed Frame Bushing | 2 | 62 | Screw M3 * 10 | 10 |
| 27 | Washer Ø16*Ø6.5*1.0 | 4 | 63 | Bolt M6 * 15 | 1 |
| 28 | Upper Bed Frame Bushing | 1 | 64 | Carriage Bolt M8 * 70 | 2 |
| 29 | Handlebar | 2 | 65 | Bolt M6 * 30 | 1 |
| 30 | Knob | 1 | 66 | Spacer Ø22*16.8 | 2 |
| 31 | Rubber Heel Holder | 4 | 67 | Screw ST4.2 * 12 | 8 |
| 32 | Nylon Strap | 1 | 68 | Screw ST4.8*20 | 1 |
| 33 | Loop Strap | 1 | 69 | Shaft Nut Ø8 | 1 |
| 34 | Strap Lock | 1 | 70 | Bolt M5 * 10 | 2 |
| 35 | Foam Bed | 1 | 71 | Bolt M8 * 50 | 4 |
| 36 | Foam Grip | 2 | 72 | Pivot Arm Ring | 2 |
| | | | 73 | Rear Left Foot Cap with Handle I | 1 |
| | | | 74 | Rear Left Foot Cap with Handle II | 1 |
| | | | 75 | Rear Right Foot Cap with Handle I | 1 |
| | | | 76 | Rear Right Foot Cap with Handle II | 1 |
| | | | 77 | Screw ST3.5*15 | 8 |
| | | | 78 | Lumbar Pad | 1 |

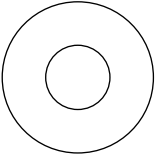
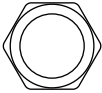
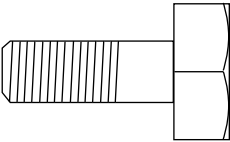
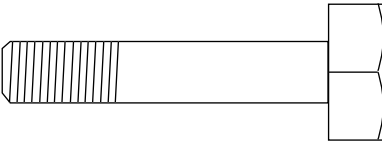
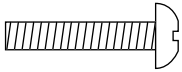
Most of the components of the following parts list have already been assembled for your convenience.

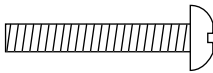
Please use the following list as a reference for ordering parts only.

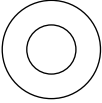
INCLUDED HARDWARE / TOOL

| Part # | Description | Quan. | |
|--------|---|-------|--|
| 13 | Washer $\varnothing 20 * \varnothing 8.5 * 1.5$ | 8 |  |
| 15 | Lock Nut M8 | 4 |  |
| 38 | Hex Head Bolt M8 * 23 | 2 |  |
| 43 | Hex Head Bolt M8 * 43 | 2 |  |
| 48 | Bolt M6 * 20 | 2 |   |
| 51 | Bolt M6 * 25 | 2 |   |
| 54 | Washer $\varnothing 13 * \varnothing 6.5 * 1.0$ | 4 |  |
| 55 | Nut Cap $\varnothing 27 * \varnothing 13.5$ | 4 |  |
| 77 | Screw ST3.5*15 | 8 |  |

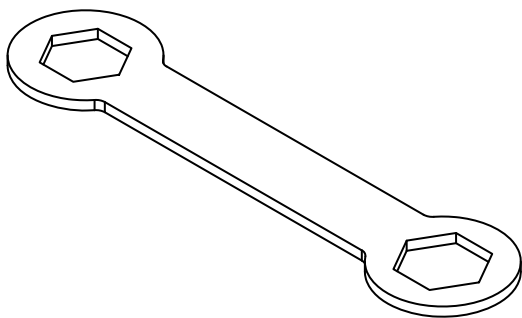

Wrench (1 pc)

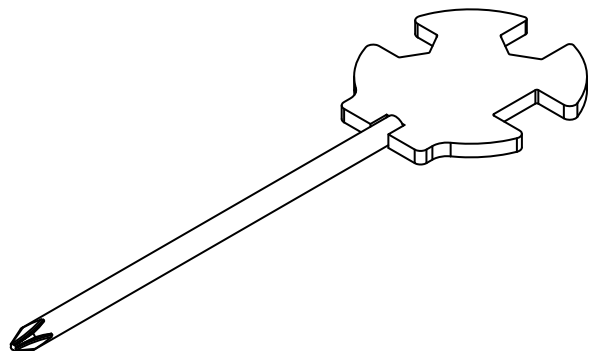

Screw Driver Wrench (1 pc)

ASSEMBLY

1 Stand up the base of the machine, by separating the u-frame.

Pull the front and Rear U-Frames (1,2) as far apart from each other as possible. Then push down on the middle of the two Folding Arms (8) until they are fully locked down.

Attach the Front Right and Left Foot Caps (49,50) to the Front U-Frame (1) each with two Screws (48,51) and Washers (54).

Attach the Rear Left Foot Cap with Handle I (73) and Rear Left Foot Cap with Handle II (74) to the left side of the Rear U-Frame (2) with four Screws (77).

Attach the Rear Right Foot Cap with Handle I (75) and Rear Right Foot Cap with Handle II (76) to the right side of the Rear U-Frame (2) with four Screws (77).

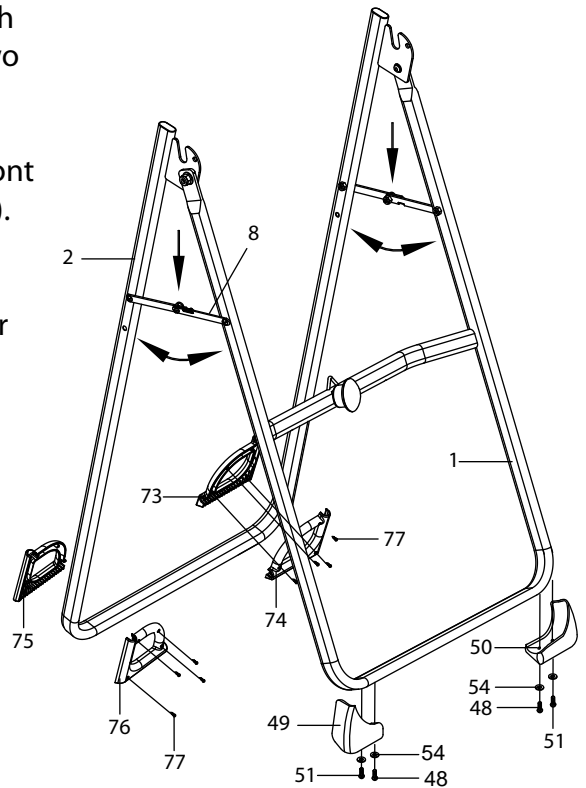

2 Install two Nut Caps (55) onto Lock Nuts (15).

Slide one Protective Cover (37) on to each side of the base as shown, and pull down on the Protective Covers (37) until the bottom of the covers are slightly lower than the Folding Arms (8).

Use the velcro straps on the bottom of the Protective Covers (37) to secure the covers to the Folding Arms (8). When the covers are assembled correctly, the Folding Arms (8) should be fully covered by the Protective Covers (37) with the logo on the outside.

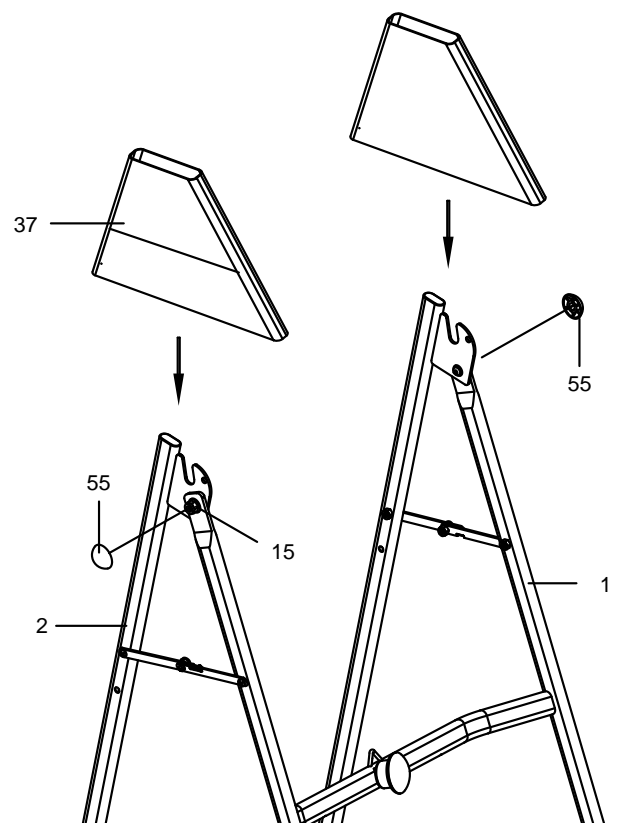

ASSEMBLY

- 3** Slide the bottom of the Pivot Arms (5) into the brackets, located at each side of the Bed Frame (4), align to the desired hole on the arm with the peg on the bracket.

Insert the peg into the hole to lock the Pivot Arms (5) in place.

It is recommended that you use the bottom hole on the Pivot Arms (5) until you become more familiar with the equipment.

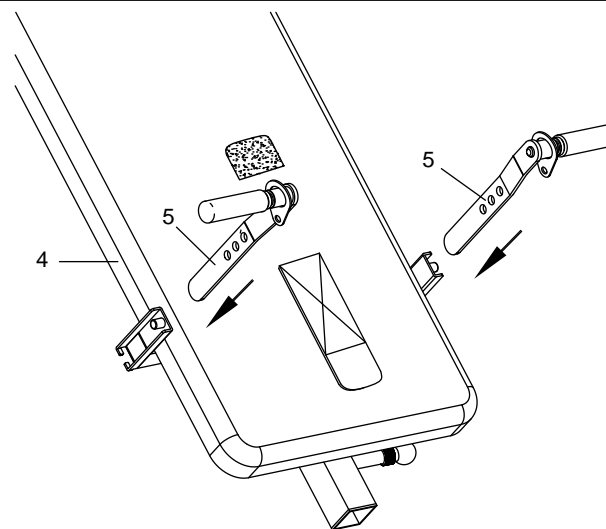

- 4** Mount the Bed Frame (4) to the Rear U-Frame (2) by inserting the ends of the Pivot Arms (5) into the channels on the plates. The slotted portion of the rollers on the end of the Pivot Arms (5) should be inserted into the channels on the plates.

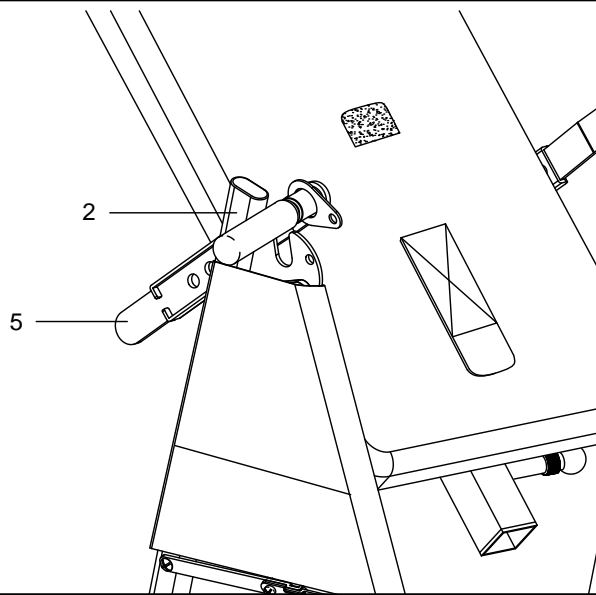

- 5** Slide the Steel Heel Holder Brackets (7) and Rubber Heel Holders (31) onto both ends of the Rear Rod (9) until the lock teeth are wedged into the slots in the Rear Rod (9) as shown in small figure. Use the same procedure to attach the other Steel Heel Holder Brackets (7) and Rubber Heel Holders (31) onto both ends of the Front Rod (11).

NOTE: Make sure the lock teeth are wedged into the slots in the Rear and Front Rods (9, 11) to lock the Steel Heel Holder Brackets (7) and Rubber Heel Holders (31) in place before use.

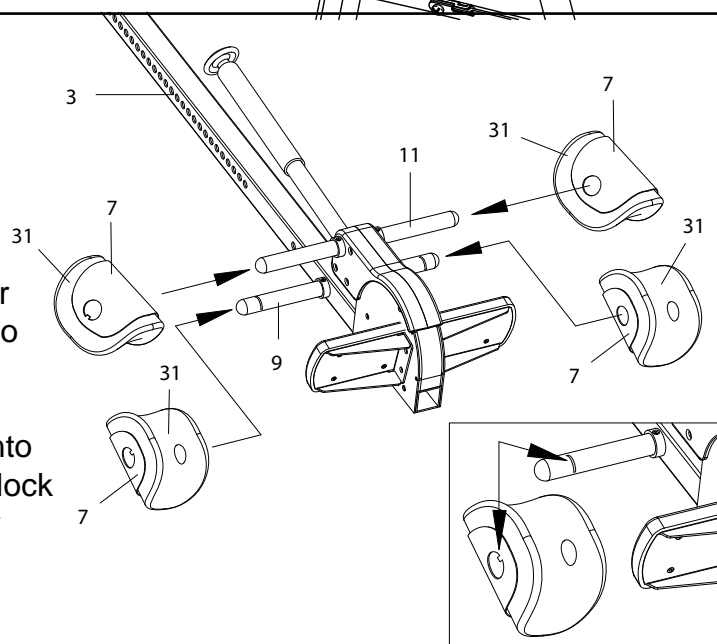

ASSEMBLY

- 6** Pull out the Large Spring Knob (18), and slide the Adjustable Boom (3) into the square bracket on the bottom of the Bed Frame (4) as shown.

Slide the Adjustable Boom (3) upward until the desired height on the Height Scale (44) is just below the bracket on the bed frame.

Lock the Adjustable Boom (3) in place by releasing the Large Spring Knob (18) and sliding the Adjustable Boom (3) up or down slightly until the Large Spring Knob (18) "pops" down into the locked position.

For added safety, secured the Knob (30) into the back side of the bracket on the Bed Frame (4) as shown.

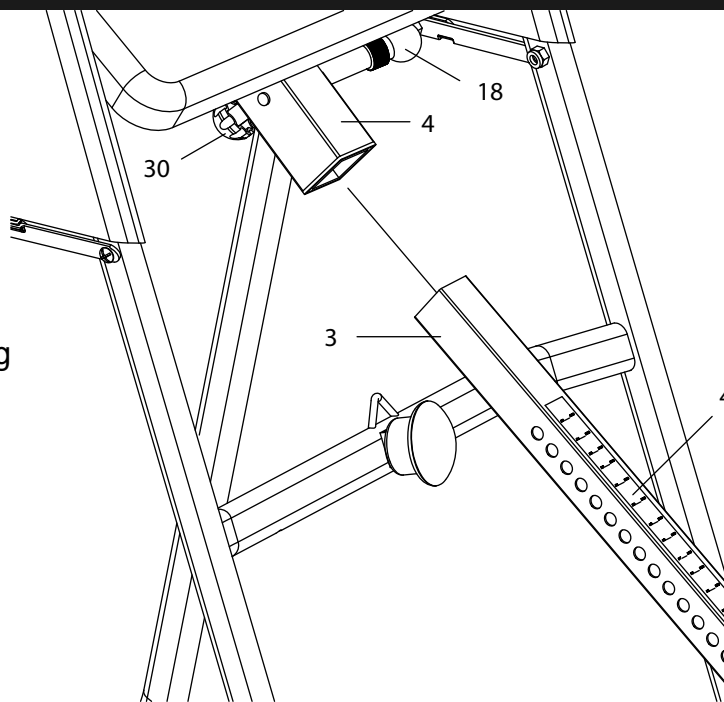

- 7** Attach the top end of Handlebar (29) onto the Rear U-Frame (2) and Pivot Arm Ring (72) with one Hex Head Bolt (38), Lock Nut (15), and two Washers (13).

Attach the bottom end of the Handlebar (29) onto the Rear U-Frame (2) with one Hex Head Bolt (43), Lock Nut (15), and two Washers (13).

Install the Nut Cap (55) onto the Hex Head Bolt (38).

Repeat above same steps to attach the other Handlebar (29) onto the Rear U-Frame (2) and Pivot Arm Ring (72).

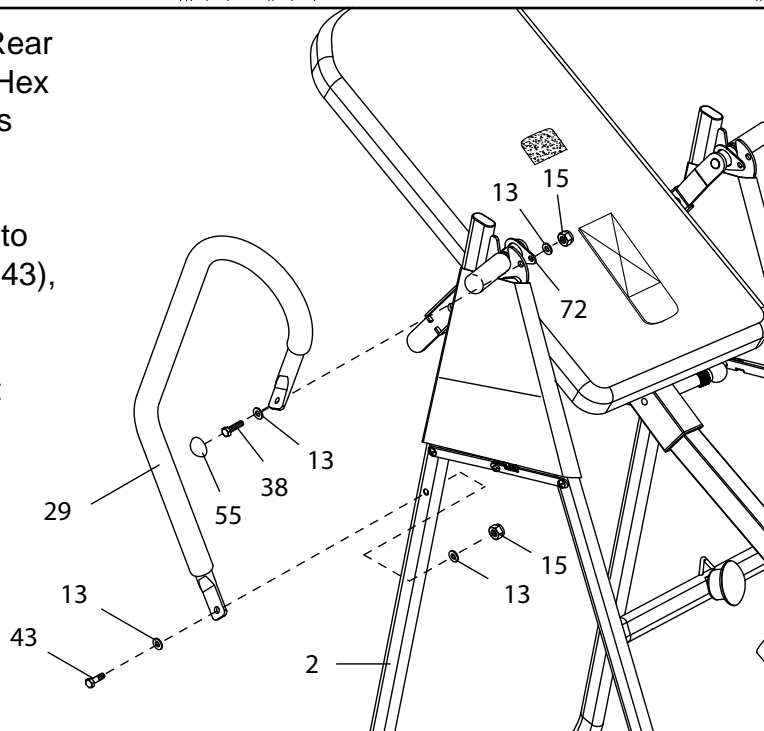

- 8** Attach the Nylon Strap (32) to the Strap Lock (34) by inserting the end of the Nylon Strap (32) up through the bottom of the Strap Lock (34), loop the Nylon Strap (32) over the Pre-assembled Loop Strap (33) and down through the Strap Lock (34). Now, loop the strap back over itself, and insert back through the Strap Lock (34), and pull tight to secure.

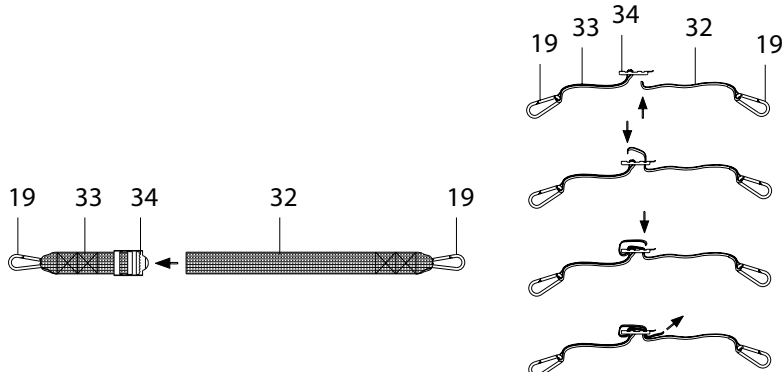

ASSEMBLY

- 9 Attach the Nylon and Loop Straps (32,33) to the Inversion Table by hooking the end of the Nylon Strap (32) to the pre-assembled loop on the back of the Bed Frame (4) as shown. Then hook the other end of Loop Strap (33) to the other Pre-assembled loop on the Front U-Frame (1) as shown.

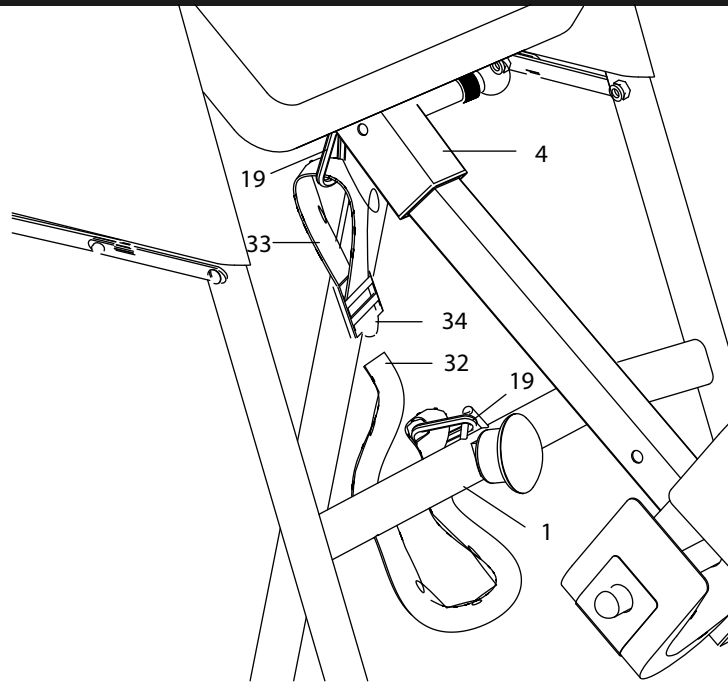

- 10 Insert the velcro strap from the Foam Bed (35) to the underneath of Lumbar Pad (78) and secure the Lumbar Pad (78) onto the Foam Bed (35).

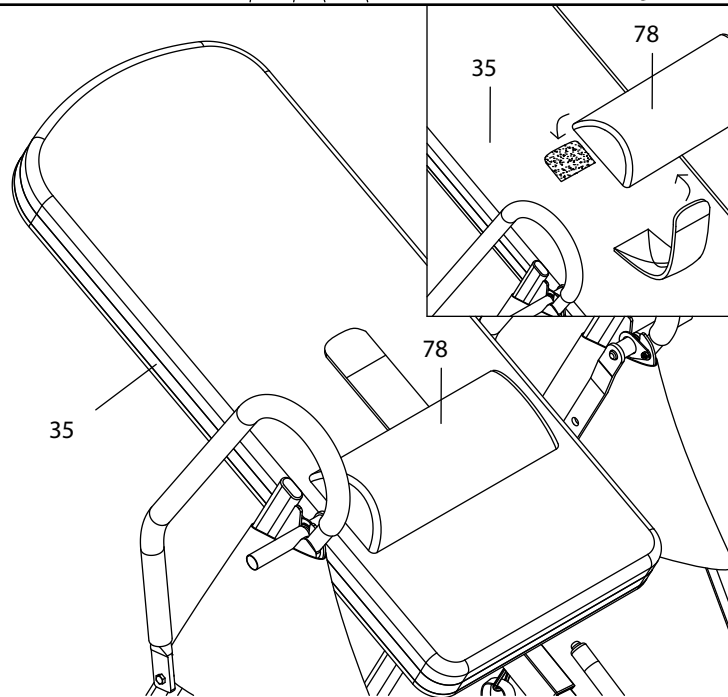

HOW TO USE

Pivot Arm

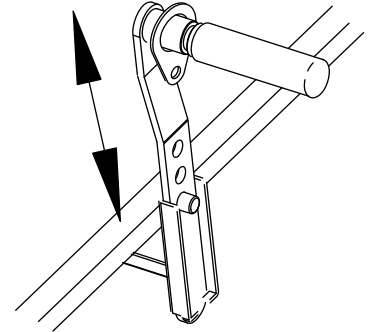
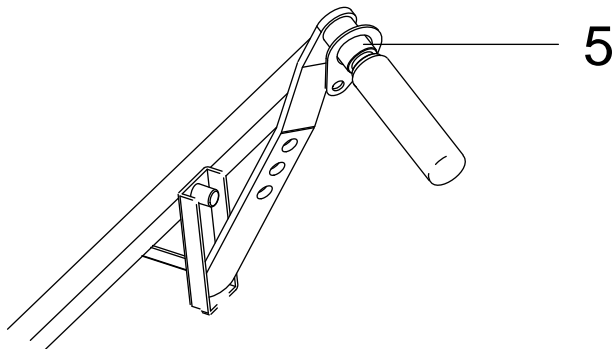

The Pivot Arms (5) can be adjusted to allow for a greater or lesser degree of inversion. To adjust the Pivot Arms (5) simply pull out on them until the post is out of the hole, slide them up or down to the desired hole, push in until the post goes through the desired hole, The bottom hole provides the least amount of inversion, while the top hole provides the greatest amount, It is recommended that beginners use the bottom hole until they are familiar with the inversion table.

NOTE: Both Pivot Arms (5) must be adjusted to the same hole. Trying to adjust the Pivot Arms (5) on two different positions could cause damage to the inversion table, or injury to the user.

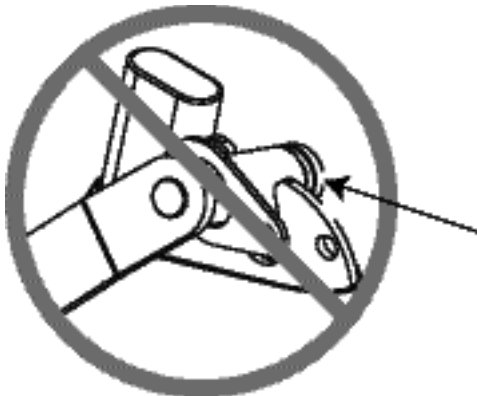

Pivot arm is NOT aligned correctly. The pivot arm is not inserted all the way into the curved slot.



Make sure the pivot arm is inserted all the way into the slot. Pivot arm is aligned correctly when the groove sits directly on the curved slot and the pivot arm is able to rotate freely.

WARNING: Make sure both pivot arms are in the same hole to prevent serious injury from occurring.

HOW TO USE

Strap adjustment

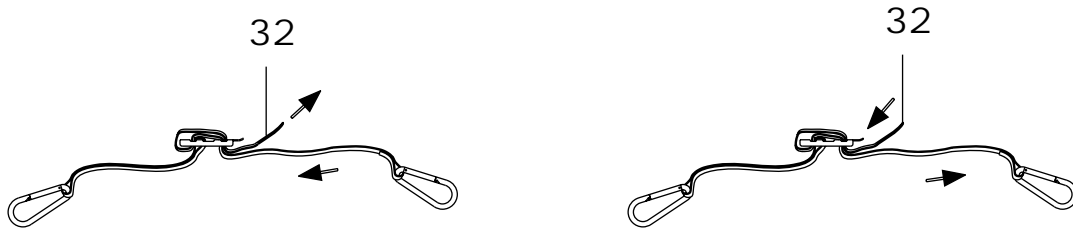

For added safety, a nylon strap has been included to restrict the degree of inversion. This strap can be adjusted to different lengths to allow for a greater or lesser degree of inversion. To lengthen the Nylon Strap (32) feed the top end of Nylon Strap (32) into the strap lock, and pull on the lower end of the strap. To shorten the length feed the bottom end of Nylon Strap (32) into the strap lock, and pull on the top end.

Adjusting the boom

The Adjustable Boom (3) can be moved to a variety of different positions, in order to accommodate the height of the person on the inversion table. To adjust the boom loosen the knob (30), pull out the Large Spring Knob (18), and slide the boom up or down until the desired height on the Height Scale (44) is positioned just below the Square Bushing (26). When the boom is in the desired position, simply release the Large Spring Knob (18), slide the boom slightly up or down until the Large Spring Knob (18) locks into place, and tighten the Knob (30).

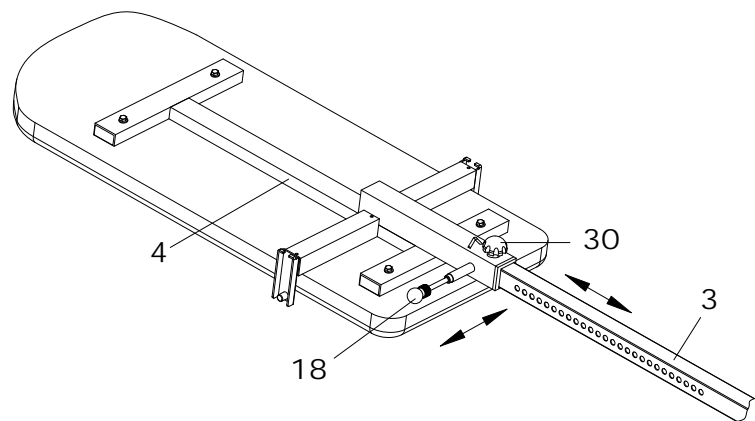

Balancing Inversion table

The inversion table is like a very sensitively balanced fulcrum. It responds to very slight changes in weight distribution. So, it is very important to make sure that the height is adjusted properly. To do this, mount the inversion table, lock your ankles into the heel holders, and lie back with your hands at your sides. Slowly place your hands across your chest. While in this position, your head should still be above your feet. If your feet are above your head, dismount and adjust the height again.

HOW TO USE

Using the inversion table

1. Start by lying fully back on the bed with your hands at your side, or resting on your thighs.
2. Keeping your hands close to your body begin to raise your arms slowly allowing the table to rotate backward. Stop, or lower your arms to control the downward rotation of the table.
3. Raise your arms until they are over your head. At this point, the inversion table will be as far back as it can go.
4. As you get more comfortable with the use, rock the bed slowly by moving your arms up and down slowly.
5. It is recommended that the inversion table be used for five or ten minutes each morning, and again each evening.
6. Return to the upright position by slowly moving your hands back down to your thighs.

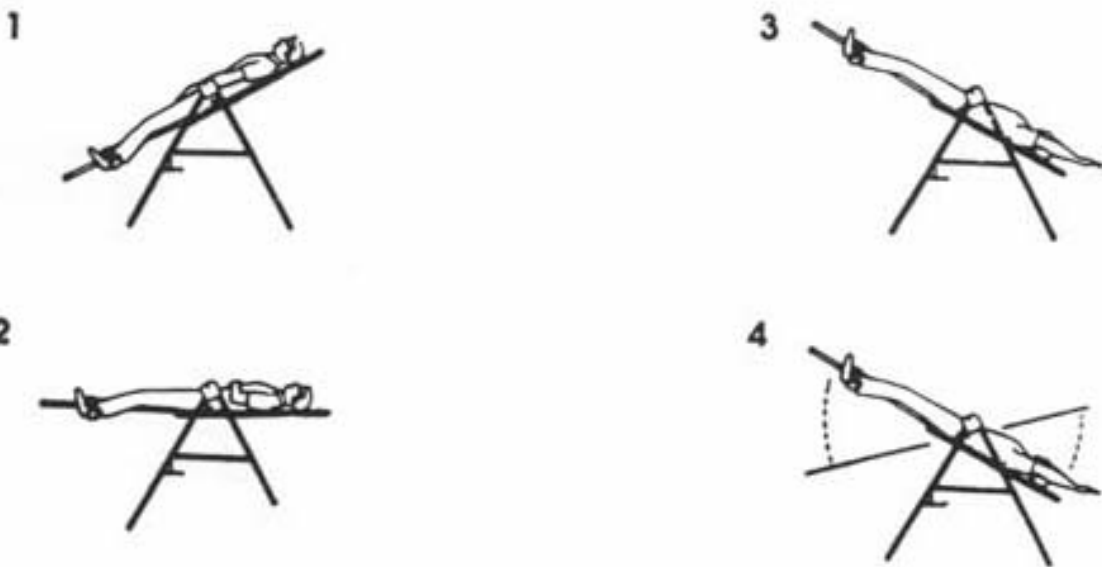

Suggestion for use

1. Begin slowly: invert only 15~20 degrees to begin with. Stay inverted only as long as you are comfortable. Return upright slowly.
2. Make gradual changes: increase the angle only if it is comfortable. Increase angle only a few degrees at a time. Increase the time of use 1~2 minutes up to ten over a period of weeks. Add stretching and light exercise only after you are comfortable with inversion.
3. Watch your body: come up slowly, dizziness after a session means you came up too fast. Wait a while after eating before using table. If you get nauseous, do not fight it, come up as soon as you feel queasy.
4. Keep moving: movement while inverted encourages blood, circulation. Movement may be accomplished by either rhythmic traction or light exercise. Do not exercise strenuously while inverted, limit partial inversion without movement to one or two minutes. Limit full inversion with no movement to only a few seconds.
5. Invert regularly: we recommend two or three times a day depending upon your current condition. Try to schedule it for the same times each day.

STORAGE

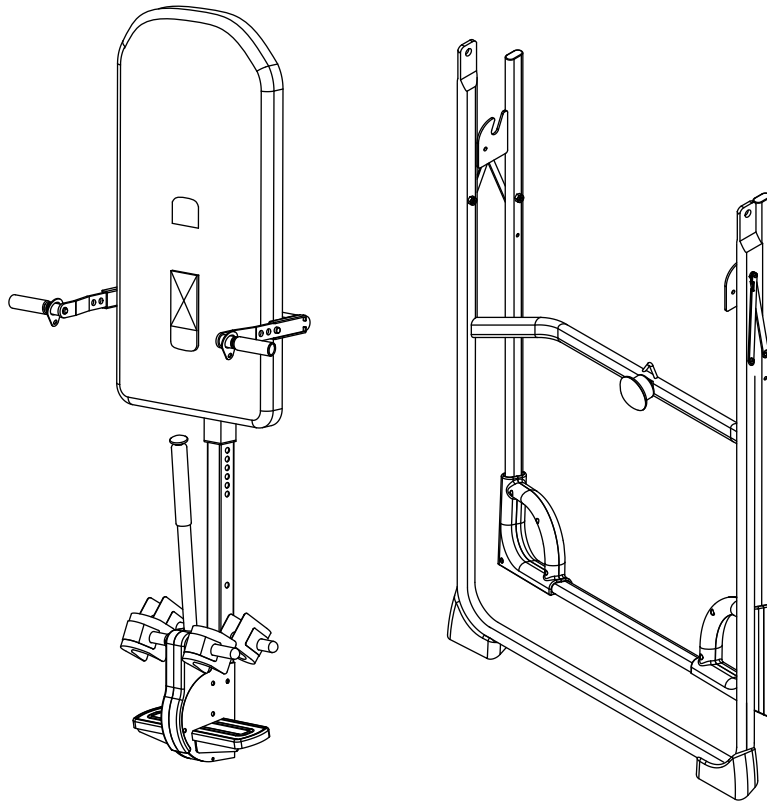

For your storage convenience, the inversion table can be folded down to place against a wall, under a bed, or in a storage area.

MAINTENANCE INSTRUCTIONS

You should check your INVERSION TABLE for any kind of wear and tear before every use.

1. Check the pivot arms, foam bed, heel holder brackets, nylon straps, and the strap buckle for wear and tear.
2. Replace damaged and worn components immediately.
3. Please keep all damaged equipment out of use until it is repaired.

PLACEMENT OF WARNING LABELS

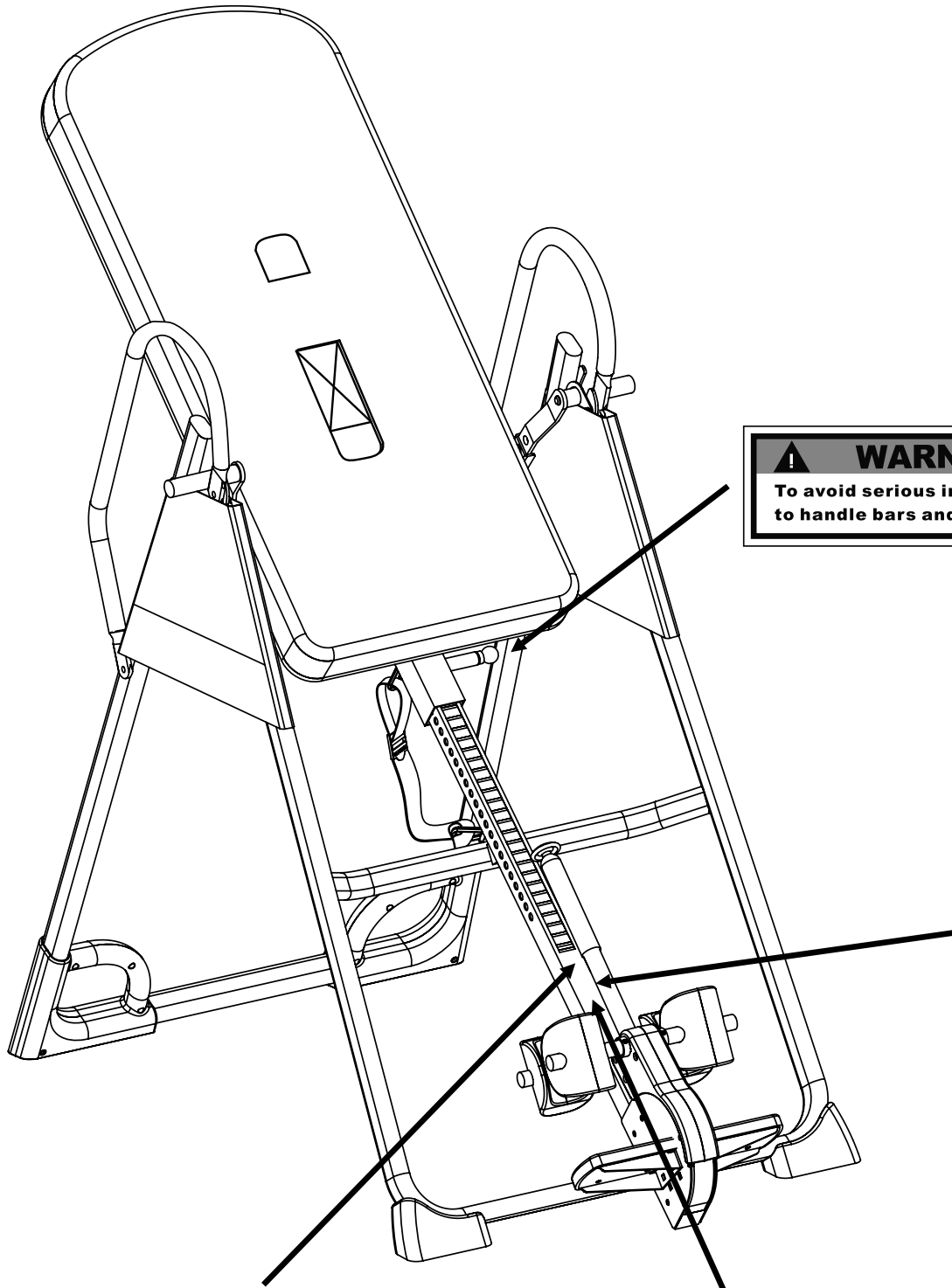

⚠ WARNING
To avoid serious injury, hold on to handle bars and invert slowly.

⚠ WARNING
Feet must be secured properly before use

⚠ WARNING
Maximum weight capacity is 350lbs

⚠ WARNING
THIS EQUIPMENT IS INTENDED FOR USE BY ADULTS AND CHILDREN 12 YEARS AND OLDER. POSSIBILITY OF SEVERE INJURY OR DEATH IF USED IMPROPERLY. PLEASE FOLLOW ALL DIRECTIONS BEFORE USE.
KEEP PERSONS UNDER THE AGE OF 12 AWAY!
REPLACE LABELS IF THEY ARE DAMAGED, ILLEGIBLE, OR REMOVED.
PLEASE REVIEW ALL WARNING AND INSTRUCTIONS BEFORE ASSEMBLY AND USAGE. ALL INSTRUCTIONS SHOULD BE FOLLOWED PRIOR TO ASSEMBLY AND USAGE.

WARM-UP

The **WARM-UP** is an important part of any workout. It should begin every session to prepare your body for more strenuous exercise by heating up and stretching your muscles, increasing your circulation and pulse rate, and delivering more oxygen to your muscles.

HEAD ROLLS

Rotate your head to the right for one count, feeling the stretch up the left side of your neck, then rotate your head back for one count, stretching your chin to the ceiling and letting your mouth open. Rotate your head to the left for one count, then drop your head to your chest for one count.



SHOULDER LIFTS

Lift your right shoulder toward your ear for one count. Then lift your left shoulder up for one count as you lower your right shoulder.



SIDE STRETCHES

Open your arms to the side and lift them until they are over your head. Reach your right arm as far toward the ceiling as you can for one count. Repeat this action with your left arm.



QUADRICEPS STRETCH

With one hand against a wall for balance, reach behind you and pull your right foot up. Bring your heel as close to your buttocks as possible. Hold for 15 counts and repeat with left foot.



INNER THIGH STRETCH

Sit with the soles of your feet together and your knees pointing outward. Pull your feet as close to your groin as possible. Gently push your knees toward the floor. Hold for 15 counts.



TOE TOUCHES

Slowly bend forward from your waist, letting your back and shoulders relax as you stretch toward your toes. Reach as far as you can and hold for 15 counts.

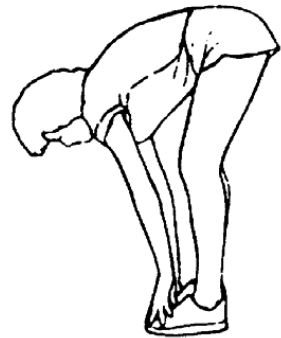

HAMSTRING STRETCHES

Extend your right leg. Rest the sole of your left foot against your right inner thigh. Stretch toward your toe as far as possible. Hold for 15 counts. Relax and then repeat with left leg.



CALF/ACHILLES STRETCH

Lean against a wall with your left leg in front of the right and your arms forward. Keep your right leg straight and the left foot on the floor; then bend the left leg and lean forward by moving your hips toward the wall. Hold, then repeat on the other side for 15 counts.



ONE YEAR LIMITED WARRANTY

Paradigm Inc. warrants to the original purchaser that this product is free from defects in material and workmanship when used for the purpose intended, under the conditions that it has been installed and operated in according to Paradigm's Owner's Manual.

Paradigm's obligation under this warranty is limited to replacing or of charge, any parts which may prove to be defective under normal home use. This warranty does not include any damage caused by improper operation, misuse or commercial application.

From the date of purchase, the frame is warranted to be free from defects for 1 (one) year. All parts and workmanship, including inversion components, upholstery, and hardware are to be free from defects for 90 days. This warranty is offered only to the original owner and is not transferable. Proof of purchase is required.

TROUBLE SHOOTING SECTION

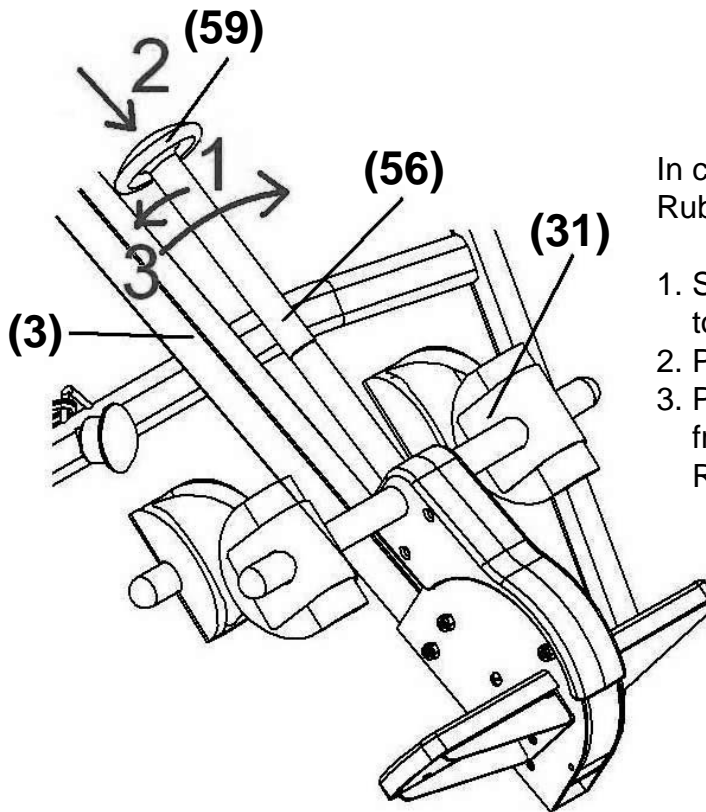

In case the Adjustable Handle (56) is too tight to release Rubber Heel Holder (31), please follow these steps:

1. Slightly pull the Adjustable Handle (56) toward the Adjustable Boom (3).
2. Press the Button (59).
3. Push the Adjustable Handle (56) away from the Adjustable Boom (3) to release the Rubber Heel Holder (31).

