

EZ-Up™ Inversion Rack

PRE-ASSEMBLY

Before you begin: These instructions will guide you in properly assembling the unit. Please review all the steps before beginning assembly. Carefully adhere to the Assembly Instructions and User Instructions to help ensure user safety and product integrity.

⚠ WARNING

1. It is your responsibility to familiarize yourself with the proper use of the equipment and the inherent risks of inversion, such as falling on your head or neck, pinching, entrapment or equipment failure.
2. This product is not designed for persons over 250 lbs (113.6 kg) Structural failure could occur or head/neck may impact floor during inversion. Serious injury or death could result.
3. DO NOT use with the EZ-Up Inversion Rack in doorways wider than 36" (91 cm).
4. ONLY use in solid wood doorways built according to national building codes. DO NOT use in faux or metal doorways.
5. You must use the screws provided. DO NOT substitute with other length screws.
6. DO NOT use the equipment without a licensed physician's approval and a review of the medical contraindications, as noted in the Owner's Manual.
7. Failure to assemble and/or use the equipment as directed may void the manufacturer's warranty on this product and could result in injury or death.
8. DO NOT use the EZ-Up Inversion Rack until you have thoroughly and carefully read the Owner's Manual, viewed the Instructional Video, reviewed product labeling and all other accompanying documents, and inspected the equipment.
9. The steps in the video directly coincide with the steps detailed in these Assembly Instructions.
10. Make sure that all fasteners are secure.
11. Follow each step in sequence. Do not skip ahead.
12. ONLY one person at a time should use the EZ-Up™ Inversion Rack.
13. Prior to use, test and inspect the EZ-Up Inversion Rack to ensure secure installation.
14. Replace defective parts immediately and/or keep the equipment out of use until repair.

Carefully remove the individual parts from the carton. You should have all of the items listed below. If any items are missing or damaged, contact your retailer or customer service directly (See Pg. 2 of the Owner's Manual).

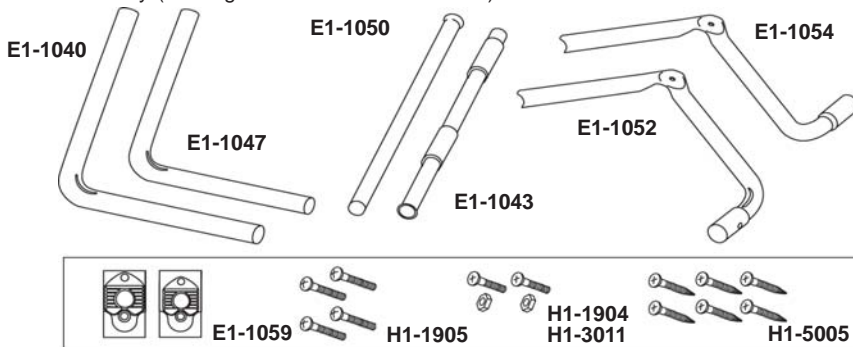

Items for Assembly:

Item #	Item #
Large diameter 'L' Bar	E1-1040
Small diameter 'L' Bar	E1-1047
Small Straight Bar w/ Warning Label	E1-1050
Large Straight Bar w/ Blue Foam	E1-1043
Large diameter 'Elbow' Bar	E1-1052
Small diameter 'Elbow' Bar	E1-1054
Two (2) Locking Brackets	E1-1059
Four (4) 2" (5 cm) Bolts	H1-1905
Two (2) Bolts: 1 - 1 3/4" (4.4 cm); 1 - 1 1/2" (3.8 cm)	H1-1904
w/ Lock Nuts	H1-3011
Six (6) 2" (5 cm) Wood Screws	H1-5005

Not included: Medium Phillips Head screwdriver, Adjustable Wrench, Drill motor w/ 5/32" drill bit.

ASSEMBLY

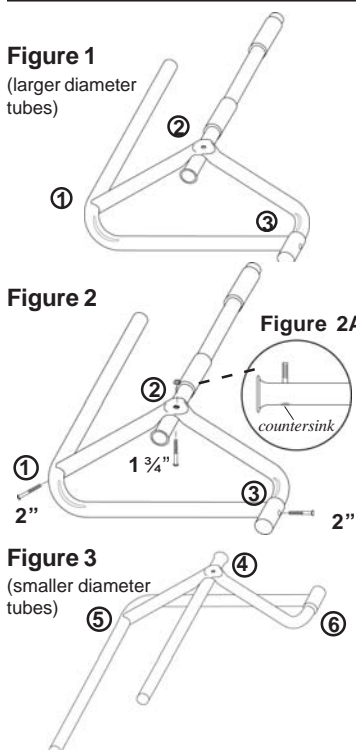

STEP 1.

Assemble the three larger diameter tubes (E1-1040, E1-1043, E1-1052) which are marked by a 1, 2 and 3 at each joint:

- Separate the three larger diameter tubes from the three smaller diameter tubes. The larger diameter tubes use joint numbers 1, 2, and 3.
- Lay out the three larger tubes in relationship to each other. See *Figure 1*. Be sure that the parts are assembled so that 1 mates to 1, 2 mates to 2, and 3 mates to 3.
- Loosely assemble joints 1 and joints 3 using the 2" (5 cm) bolts (H1-1905). See *Figure 2*. **DO NOT TIGHTEN THE BOLTS YET.**
- Loosely assemble joint 2 with the 1 3/4" (4.4 cm) bolt (H1-1904) and lock nut (H1-3011). Insert the bolt so that its head fits in the countersink. See *Figure 2A*.

STEP 2.

Assemble the three smaller diameter tubes (E1-1047, E1-1050, E1-1054) which are marked by a 4, 5 and 6 at each joint:

- Lay out the three smaller diameter tubes in relationship to each other. See *Figure 3*. Be sure that the parts are assembled so that 4 mates to 4, 5 mates to 5, and 6 mates to 6.
- Loosely assemble joints 5 and joints 6 using the 2" (5 cm) bolts (H1-1905). **DO NOT TIGHTEN THE BOLTS YET.**
- Loosely assemble joint 4 with the 1 1/2" (3.8 cm) bolt (H1-1904) and lock nut (H1-3011). Insert the bolt so that its head fits in the countersink. See *Figure 2A*.

ASSEMBLY

Figure 4

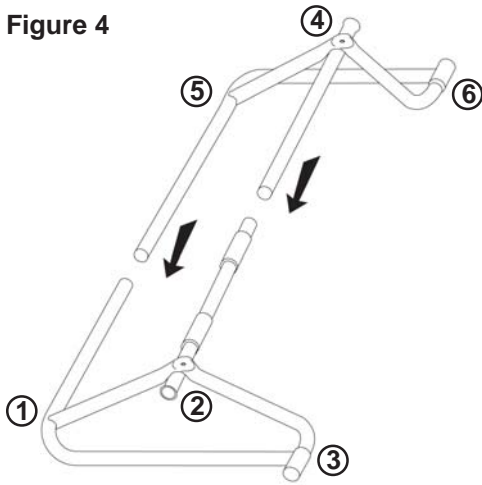

Figure 5

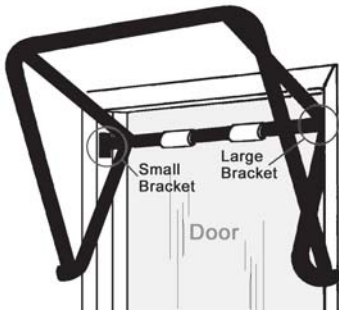

Figure 6

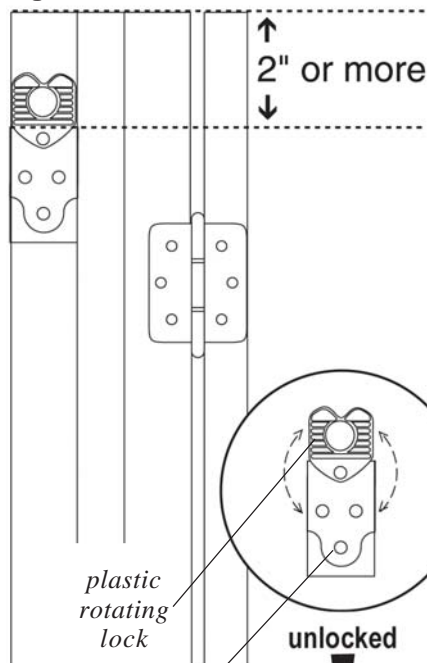
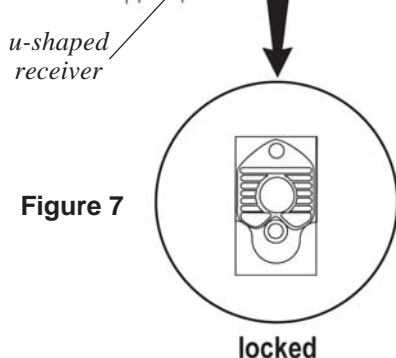

Figure 7



STEP 3. Final Assembly:

- Slide the smaller half into the larger half. See Figure 4. Tighten all bolts using a screwdriver and wrench. The width of the EZ-Up™ Inversion Rack may be adjusted to fit doorways 28 to 36" (71 to 91 cm) wide by sliding the smaller half in or out, depending upon the size of your door frame.

STEP 4. Installation of Locking Brackets:

- **Important:** There are two sizes of Locking Brackets, one to fit the Large Straight Bar (with blue hand grips) and one to fit the Small Straight Bar (with red warning label). The Locking Brackets should mount on the door frame opposite from the hinged door, to allow use of the equipment without interfering with operation of the door. See Figure 5. With your back to the door, the large Locking Bracket will mount on your left and the small Locking Bracket on your right.
- Install the first Locking Bracket as shown in Figure 6. Place the Locking Bracket against the doorstop edge, and 2" (5 cm) or more down from the top of the door frame.
- Mark and then drill three 5/32" (3.9 mm) diameter holes and drill at least 2" (5cm) deep into the door frame.
- Mount the Locking Bracket using the three wood screws provided (H1-5005). Screws must fully engage the door frame.
- Install the second Locking Bracket on the opposite side of the door frame at the same height as the first Locking Bracket. After both Locking Brackets are installed, extend your EZ-Up™ Inversion Rack out to the width of the door frame and hook the flared tube ends into the u-shaped receiver in each Locking Bracket.
- Lock the EZ-Up™ Inversion Rack into the Locking Brackets by snapping the plastic, rotating lock over the top of the bar. See Figure 7. **IMPORTANT:** Always check to make sure the tubes are securely locked in place before hanging on the rack.

⚠ WARNING

1. Failure to properly install Locking Brackets could result in equipment failure.
2. Always check to make sure the Inversion Rack is securely locked in place.

STEP 5.

Weight Test EZ-Up Inversion Rack for Proper Installation:

After installing the Locking Brackets and securing the EZ-Up™ Inversion Rack in place:

- Two people should hang by their hands from one end of the rack (one person on the upper bar and one on the lower bar).
- While hanging, bounce up and down several times. Next, both people should hang from the other end and repeat the test. **IMPORTANT:** If the door frame is unstable or weak, DO NOT continue use of the rack in that door frame.

⚠ WARNING

3. Failure to test installation as outlined in these instructions could lead to equipment failure, resulting in serious injury or death!

⚠ WARNING

Important Safety Instructions:

It is your responsibility to familiarize yourself with the proper use of the equipment and the inherent risks of inversion, such as falling on your head or neck, pinching, entrapment or equipment failure. FAILURE TO FOLLOW INSTRUCTIONS OR HEED WARNINGS COULD RESULT IN SERIOUS INJURY OR DEATH.

Restrictions on Use

- **DO NOT** use the equipment without a licensed physician's approval. Carefully review the following list of medical contraindications for inversion with your licensed physician: (This is not an exhaustive list, it is intended only for reference)
 - Middle ear infection
 - Extreme obesity
 - Pregnancy
 - Hiatal hernia
 - Ventral hernia
 - Glaucoma
 - Retinal detachment
 - Conjunctivitis
 - High blood pressure
 - Hypertension
 - Heart or circulatory disorders
 - Spinal injury
 - Cerebral sclerosis
 - Acutely swollen joints
 - Recent stroke or transient ischemic attack
 - Bone weakness (osteoporosis)
 - Recent or unhealed fractures
 - Medullary pins
 - Surgically implanted orthopedic supports
 - Use of anticoagulants (including high doses of aspirin)
- **DO NOT** use with the EZ-Up Inversion Rack if you are over 250 lbs (113.6 kg). Structural failure could occur during inversion.
- **DO NOT** modify the equipment or use accessory attachments that are not recommended by the manufacturer. Utilize the equipment for its intended purpose only.
- This product is not intended for use in public facilities.

Precautions Before Using

- **DO NOT** use until you have thoroughly and carefully read all the instructions, reviewed product labeling, viewed the instructional video, and inspected the equipment.
- **NEVER** allow children to use the equipment unsupervised.
- **DO NOT** operate equipment while under the influence of drugs, alcohol, or medication that may cause drowsiness or disorientation.
- **ALWAYS** inspect the equipment prior to use. Make sure that all fasteners are secure.
- **ALWAYS** replace defective components immediately and/or keep the equipment out of use until repair.

Precautions During Use

- **ALWAYS** use EZ-Up Inversion Rack with properly worn Gravity Boots. Failure to heed this warning may result in serious injury or death.
- **ALWAYS** work with a spotting partner until you are fully confident in your ability to get down from an inverted position.
- **DO NOT** use aggressive movements, or use weights, elastic bands or any other stretching device while inverting.

PRIOR TO USE

Make sure to weight test the EZ-Up™ Inversion Rack for proper installation. After installing the Locking Brackets and securing the EZ-Up™ Inversion Rack in place, two people should hang by their hands from one end of the rack (one person on the upper bar and one on the lower bar). While hanging, bounce up and down several times. Next, both people should hang from the other end and repeat the test. ***If the door frame is unstable or weak, DO NOT continue use of the rack in that door frame.***



Figure 8

USING THE EZ-Up™ INVERSION RACK

Mounting (See Figure 8):

- Grasp the foam hand grips on the lower bar. Swing one leg up and place your foot on the upper bar.
- Raise your other foot up and hook the boot on the upper bar.
- Shift your weight to the hooked boot and hook the second boot.
- Grasp the EZ-Reach handles to lower your body. See Figure 9.

Dismounting (See Figure 9):

- Grasp the EZ-Reach handles (as shown) to raise your body.
- Bring hands up and grasp the blue foam grips on the lower horizontal bar. To reduce the chance of dizziness while getting down, pause for 30 seconds with both hands on the lower bar while the boots are still hooked up. Relax in this position to stretch the upper back.
- Unhook one boot and place that foot against the bottom of the upper bar. See Figure 8. Shift your weight to the unhooked foot and unhook the second boot.

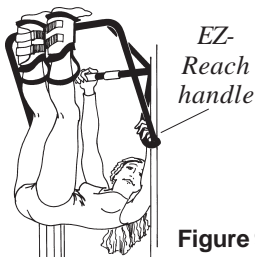

Figure 9



Figure 10

⚠ WARNING

Until you are fully confident in your ability to get down from an inverted position always work with a spotting partner.

TRY THE ULTIMATE ABDOMINAL EXERCISE— THE INVERTED SIT-UP! (See Figure 10)
Other EZ-Up™ Rack exercises include: Crunches, Reverse Squats, Twisting and Stretching, Relaxation Breathing, and Chin-ups.

HELPFUL SUGGESTIONS FOR INVERTING EZ-Up™ INVERSION RACK AND GRAVITY BOOTS

1. Begin Slowly:

- At full 90° inversion, begin with only 1-2 minutes per session.
- Stay inverted only as long as you are comfortable, even if only for a few seconds at first.
- We suggest you always have someone with you when you invert.
- Come up slowly to allow your body to readjust. Bring hands up and grasp the blue foam grips on the lower horizontal bar. To reduce the chance of dizziness while getting down, pause for 30 seconds with both hands on the lower bar while the boots are still hooked up. Dizziness after a session is a sign that you have come up too fast.

2. Make Changes Gradually:

- Increase the time only if it is comfortable; stay at 1-2 minutes for a week or more.
- You may want to increase your routine from 1-2 minutes to 5 or more over time - just listen to your body. Remember, this is not a no pain, no gain situation!
- Add stretching and light exercises only after you are comfortable with inversion.

3. Pay Attention to What Your Body Tells You:

- Remind yourself that your body is unique and it will tell you what is good for it.
- If other people invert longer, it has nothing to do with your body.
- Wait for a while after you have eaten before you invert.
- If inversion makes you nauseous, don't fight it. Come up as soon as you feel queasy, even if after only a few seconds. Give it time – it may take weeks or months before your inner ear gets used to inverting.

4. Keep Moving While Inverted:

- Movement while inverted may help make inversion a more comfortable experience and may help joints to realign and muscles to stretch and relax.

5. Do It Regularly:

- We suggest two or three short sessions of inversion each day.

⚠ WARNING

Do not use if you are over 250 lbs. / 113.6 kg.

For additional languages in Spanish, French, Dutch, German, Italian or Portuguese, please contact customer service.

Also available from Teeter Hang Ups®: Gravity Boots

• Durable, Lightweight Construction

Lightest boots on the market, without compromised durability. DuPont Hytel plastic liners, nylon-glass alloy hooks and supersoft foam liners ensure strength *and* comfort.

• Self-locking Ratchet Buckles

Double-lock system ensures a secure fit.

• Adaptable for Multiple Users

Boot straps adjust to ankles varying several inches in diameter.

• Available in XL

Diameter is 1" larger than the standard Gravity Boots; height is 1½" taller. Provides greater support and comfort for a wider range of users.



For information about the 5-year warranty, or if you have any problems assembling the equipment or questions about its use, please contact Customer Service at the appropriate location below:

USA & Canada:

STL International, Inc.
9902 162nd St. Ct. E., Puyallup, WA 98375
Toll Free (Phone) 800-847-0143 (Fax) 800-847-0188
Local (Phone) 253-840-5252 (Fax) 253-840-5757
(email) Info@STLIntl.com (web) www.STLIntl.com

International:

Inversion International, Ltd.
PO Box: AP 59245, New Providence Island, Bahamas
(Phone) +1-242-362-1001
(Fax) +1-242-362-1002
(email) Info@InversionInternational.com
(web) www.InversionInternational.com

Europe:

Teeter Ltd.
Cygnet House, Sydenham Road
Croydon, Surrey CR0 2EE, United Kingdom
(Phone) +44-(0)20-8667-0060
(Fax) +44-(0)20-8680-3999
(email) mail@TeeterLtd.com
(web) www.TeeterLtd.com