

### THANK YOU FOR CHOOSING XYLEM

Please take a few minutes to review this manual before you start installation. If you encounter any installation problems, please don't hesitate to contact us. Before you begin, please observe all local building codes. Unpack the new product and inspect for damage. The appearance of your vanity may differ from the illustrations in this guide. This instructions still apply. Please ensure the finished wall is straight and plumb and the floor is flat and perpendicular to the finished wall.

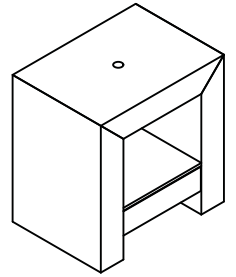

### SUGGESTED TOOLS AND MATERIALS



Philips Screwdriver



Level

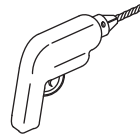

Drill

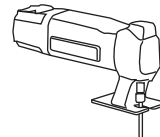

Jigsaw



Tape Measure



Safety Glasses

### ROUGH-IN DIMENSIONS

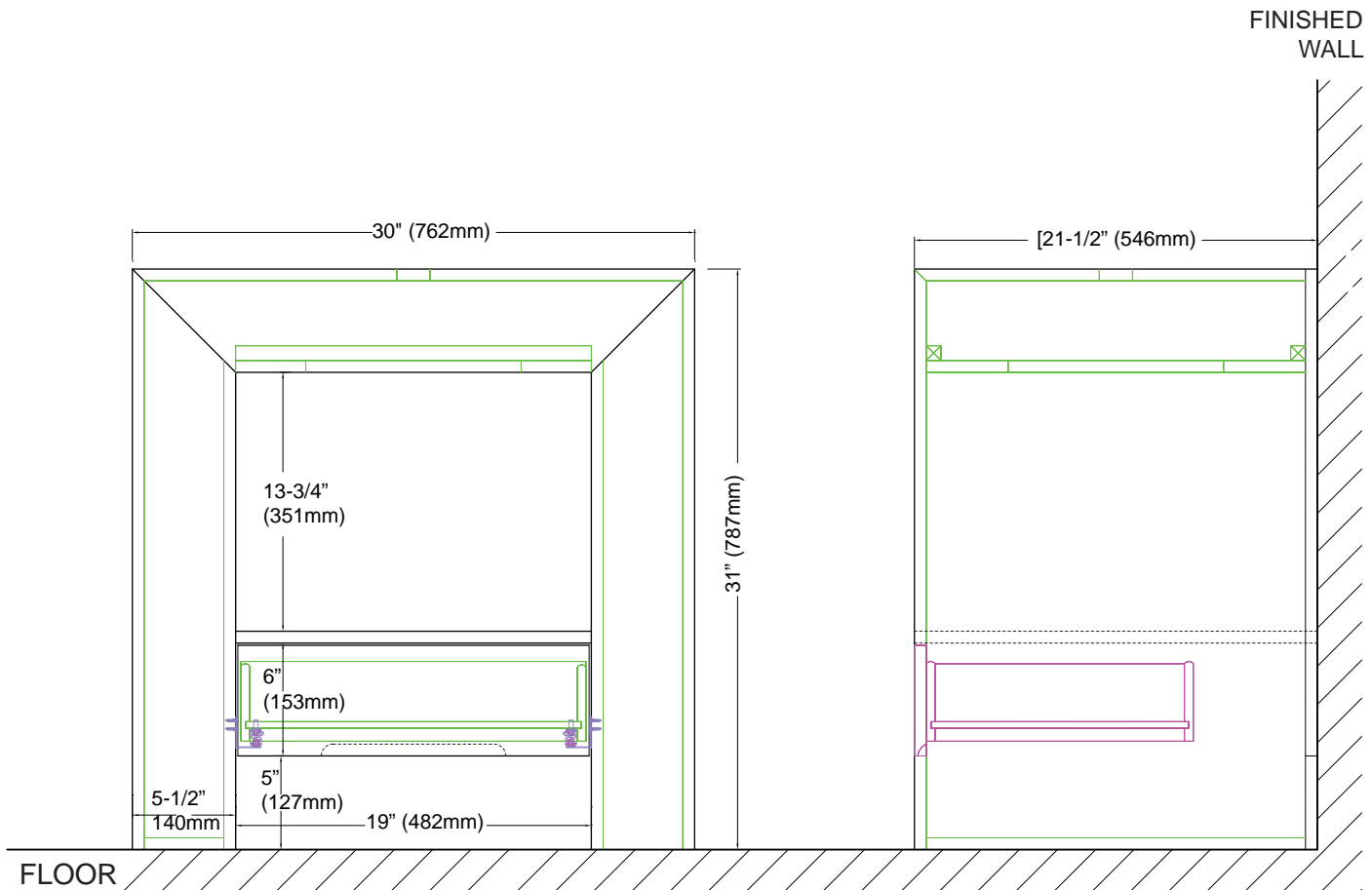

## INSTALLATION INSTRUCTIONS

PLEASE NOTE: For SVT300xx Stone Integral top installation, additional cutouts on the top of vanity may be required to accommodate the plumbing connections for the drain and faucet. The pre-drilled drain hole cutout in the vanity's wood top may be enlarged to 4" x 4" to align with the drain hole in the vanity top. To accommodate the faucet, a 3" x 10" cutout can be made to allow the faucet body and supply lines to recess into the vanity as needed.

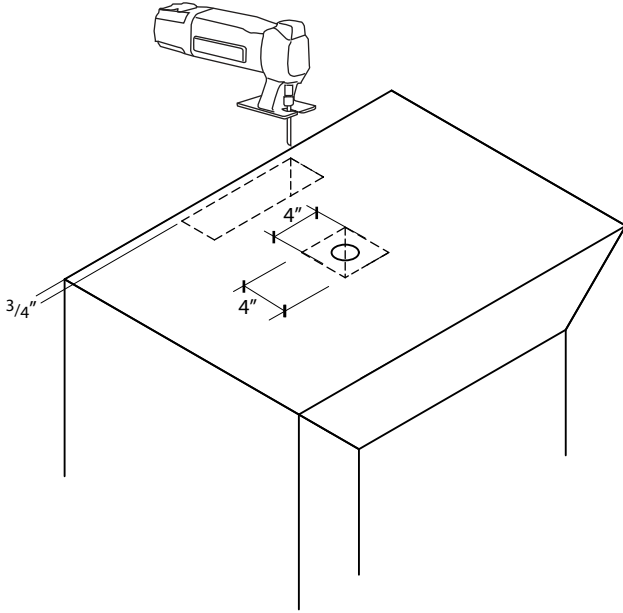

### ROUGH-IN DIMENSIONS FOR CUT OUT

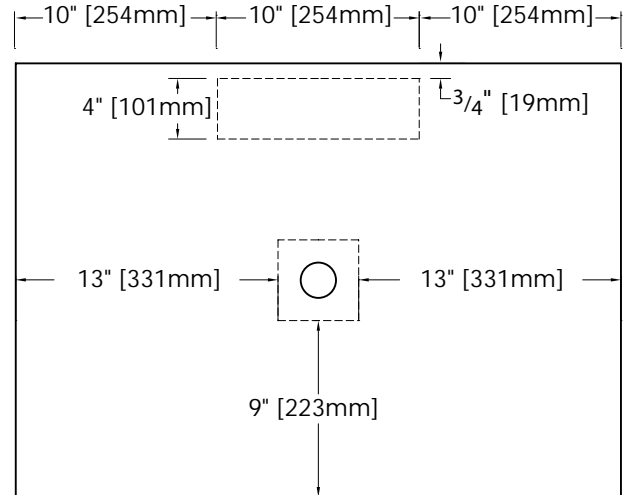

## CARE AND CLEANING

- To maintain the beauty of the finish, avoid placing the furniture in direct sunlight, as sunlight causes fading. Also avoid extreme changes in temperature by arranging furniture away from radiators, heat and air vents, and air conditioning units. Avoid placing furniture directly under windows.
- Dust the vanity frequently with a clean, soft, dry or lint-free cloth. Clean the surface by rubbing in the direction of the grain using damp lint-free cloth. Avoid using silicone cleaners and waxes.
- Clean up excess water and spills immediately. Use blotting rather than a wiping action. Water left over a long period of time will cause white spots in the finish. Please note that some chemicals may damage the finish.