

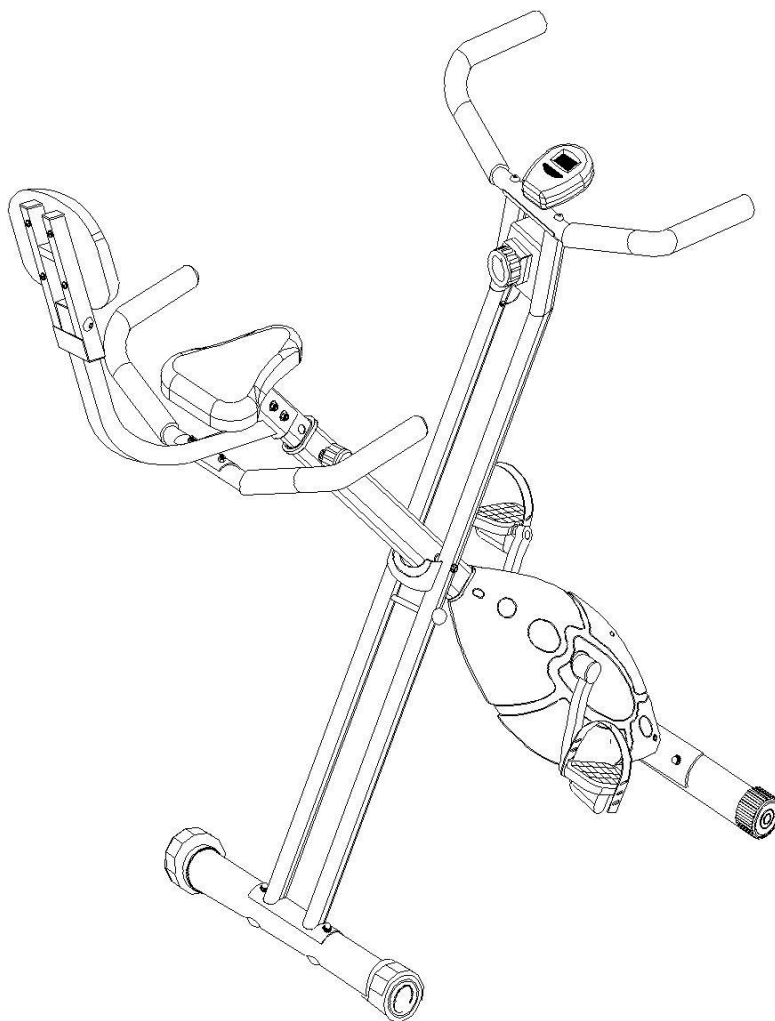

Sunny Folding Recumbent Bike

SF-RB1117

Assembly & User Manual



Please read this manual carefully before attempting to assemble or use your new product, and retain for future use.

For Customer Service, please contact: support@sunnyhealthfitness.com

Before You Start

Tools

If required, most of our products are supplied with basic tools, which will enable you to successfully assemble your product. However, you may find it beneficial to have a soft-headed hammer and perhaps an adjustable spanner handy as this may help.

Prepare the Work Area

It is important that you assemble your product in a clean, clear, uncluttered area. This will enable you to move around the product while you are fitting components and will reduce the possibility of injury during assembly.

Work with a Friend

You may find it quicker, safer and easier to assemble this product with the help of a friend as some of the components may be large, heavy or awkward to handle alone.

Open the Carton

Carefully open the carton that contains your product, taking note of the warnings printed on the carton to ensure that the risk of injury is reduced. Be aware of sharp staples that may be used to fasten the flaps as these may cause injury. Be sure to open the carton the right way up, as this will be the easiest and safest way to remove all the components.

Unpack the Components

Carefully unpack each component, checking against the parts list that you have all the necessary parts to complete the assembly of your product.

Please note that some of the parts may be pre-fitted to major components, so please check carefully before contacting our customer support team.

Safety

Before you undertake any program of exercise that will increase cardiovascular activity, please be sure to consult with your doctor. Frequent strenuous exercise should be approved by your doctor and proper use of your product is essential. Please read this manual carefully before commencing assembly of your product or starting to exercise.

*Please keep all children away from exercise product when in use. Do not allow children to climb or play on them when they are not in use.

*For your own safety, always ensure that there is at least 3 feet of free space in all directions around your product while you are exercising.

*Regularly check to see that all nuts, bolts, and fittings are securely tightened. Periodically check all moving parts for obvious signs of wear or damage.

*Clean only with damp cloth, do not use solvent cleaners. If you are in any doubt, do not use your product.

*Before use, always ensure that your product is positioned on a solid, flat surface. If necessary, use a rubber mat underneath to reduce the possibility of slipping during use.

*Always wear appropriate clothing and footwear such as training shoes when exercising. Do not wear loose clothing that could become caught or trapped during exercise.

Storage and Use

Your product is intended for use in clean dry conditions. You should avoid storage in excessively cold or damp places as this may lead to corrosion and other related problems that are outside our control.

Weight Limit

Maximum User Weight: 220 LBS

Exercise Information

Beginning

How you begin to exercise will vary from person to person. If you have not exercised for a long period of time, have been inactive for a while, or are severely overweight you must start slowly, increasing your exercise time gradually, by perhaps only a few minutes for each session per week.

Combine a carefully structured nutritious diet with a simple but effective exercise routine and this can help make you feel better, look better and will almost certainly enable you to enjoy life more.

Aerobic Fitness

Aerobic exercise is simply defined as any sustained activity that increases the supply of oxygen to your muscles via the blood pumped by your heart. With regular exercise, your cardiovascular system will become stronger and more efficient. Your recovery rate i.e. the time taken for your heart to reach its normal resting level, will also decrease.

Initially you may only be able to exercise for a few minutes each day. Do not hesitate to breathe through your mouth should you need more oxygen. Use the "talk test". If you cannot carry on a conversation while exercising, you are working too hard! However, aerobic fitness will be gradually built up with regular exercise, over the next six to eight weeks.

Do not be discouraged if it takes longer than this to begin to feel less lethargic, everyone is different and some will achieve their targets quicker than others. Work at your own, comfortable pace and the result will come. The better your aerobic fitness the harder you will have to work to stay in your target zone.

Exercising Information

Warm Up

A successful exercise program consists of three parts, Warm Up, Aerobic Exercise and Cool Down. Never start a training session without warming up. Never finish one without cooling down correctly.

Perform between five and ten minutes of stretching before starting your workout to prevent muscle strains, pulls and cramps.

Aerobic Exercise Session

Those new to exercise should exercise no more than every other day to start with. As your fitness level increases, increase this to 2 in every 3 days.

When you are comfortable with your routine, exercise for 6 days per week. Always take at least one day off per week.

Exercising In Your Target Zone

To ensure that your heart is working in its exercise target zone, you need to be able to take your pulse. If you do not have a pulse monitor, you will need to locate the pulse in your carotid artery. This is situated in the side of the neck and can be felt by using the index and middle fingers. Simply count the number of beats you feel in 10 seconds and then multiply by six to get your pulse rate. This should be taken before you start to exercise for easy reference.

People who have a greater aerobic fitness or a lower resting pulse level will also be able to exercise with a higher pulse level.

Exercising Information

Cool Down

To decrease fatigue and muscle soreness, you should also cool down by walking at a slow relaxed pace for a minute or so, to allow your heart rate to return to normal.

Warm Up and Cool Down Exercises

Hold each stretch for a minimum of ten seconds and then relax.

Repeat each stretch two or three times. Do this before your Aerobic Exercise session and also after you have finished.

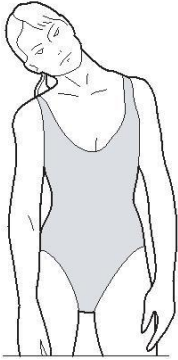

Head Roll

Rotate your head to the right for one count, feeling a slight pull on the left side of your neck. Next, rotate your head back for one count, stretching your chin. Then rotate your head to the left for one count, feeling a slight pull on the right side of your neck. Lastly, drop your head to your chest for one count. Repeat 2 to 3 times.

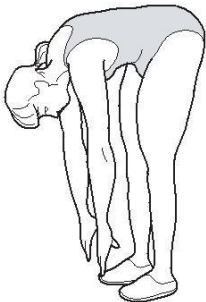

Toe Touch

Slowly bend forward from your waist, letting your back and shoulders relax as you lower your trunk. Gently stretch down as far as is comfortable and hold for 10 seconds.

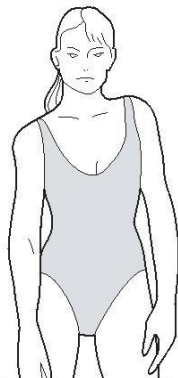

Shoulder Lift

Rotate and lift your right shoulder up towards your ear for one count. Relax then repeat for the left shoulder. Repeat 3 - 4 times.

Exercising Information



Side Stretch

Open both arm to the side and gently lift them above your head. Reach your right arm as high as you can for one count, gently stretching the muscles of the stomach and lower back. Repeat the action with your left arm. Repeat 3 - 4 times.



Inner Thigh Stretch

Sit on the floor and pull your legs toward your groin, the soles of your feet together. Hold your back straight and lean forward over your feet. Tighten the thigh muscles and hold for 5 seconds. Release and repeat 3 - 4 times.

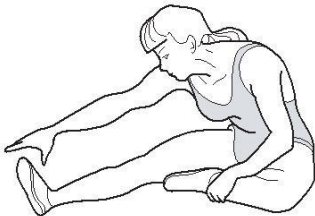

Hamstring Stretch

Sit on the floor with your right leg extended and place your left foot flat against the right inner thigh. Stretch forward toward the right foot and hold for 10 seconds. Relax and then repeat with the left leg extended. Repeat 2 -3 times.

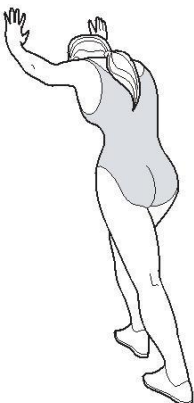

Calf / Achilles Stretch

Turn towards the wall and place both hands on it. Support yourself with one leg while the other is placed behind you with the sole flat on the floor. Bend the front leg and lean towards the wall, keeping the rear leg straight so that the calf and Achilles tendon are stretched hold for 5 seconds. Repeat with the other leg. Repeat 2 - 3 times.

Exercising Information

RESISTANCE ADJUSTMENT

To ensure smooth efficient cycling action, the tension belt braking system on your Exercise Cycle has been correctly adjusted by our factory during production.

To adjust the brake resistance during use, start by turning the Tension Control (11) fully COUNTER-CLOCKWISE at the start of your workout. Gradually increase the pedaling resistance by turning the Tension Controller Knob CLOCKWISE as required.

LEVELING THE CYCLE

For security and stability, your Cycle has a factory welded frame and once fully assembled correctly, should not need further alignment. However, in the interest of safety, please always ensure that your Cycle is positioned on a solid, flat surface. If necessary, use a rubber mat underneath to reduce the possibility of slipping while in use. If you need to make a fine adjustment simply twist the end of either Rear Frame Stabilizer Adjustable Hex End Cap (3a) to compensate for uneven floors.

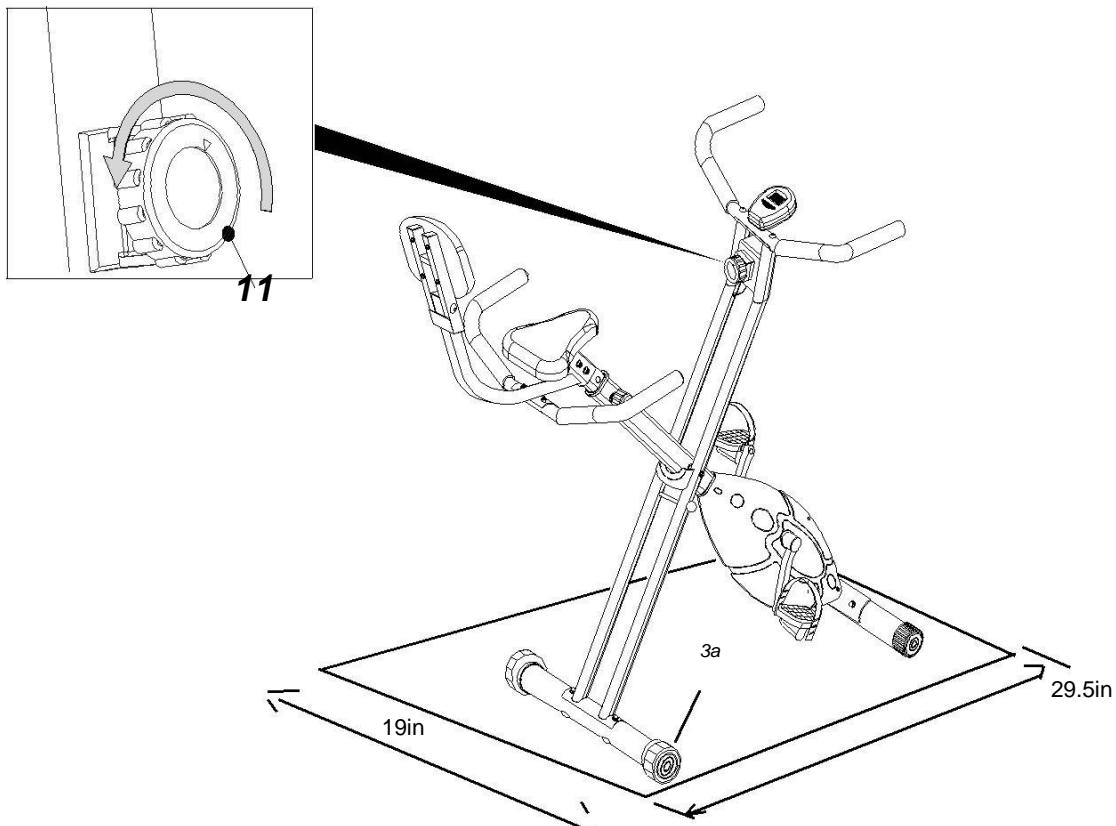

Assembly & Adjustments

EXERCISE MONITOR FUNCTIONS

The 5 function Exercise Monitor is set to start automatically when you begin to pedal. However, it is possible to switch on the monitor by pressing the Mode Button at the bottom of the monitor. To save battery consumption, the monitor will also switch off after it has been idle for approximately four minutes.

Please refer to the leaflet supplied with the Exercise Monitor for all operational functions.

LUBRICATION AND MAINTENANCE

The moving parts in your Cycle are all pre-lubricated at assembly and should not require further attention. We recommend however that the cycle is used inside and stored in a dry condition. To clean the metal and plastic components, a general household cleaner can be used, but please be sure to dry the cycle and any attachments before use. In the interest of safety, do NOT use polish or any lubricant on the saddle, foam handgrips or pedals.

Assembly & Adjustments

HOW TO FOLD

Using Locking Pin (12) to fold and unfold the Bike. When the bike is unfolded, the Locking Pin (12) is in position A. When the bike is folded, the Locking Pin (12) is in position B.

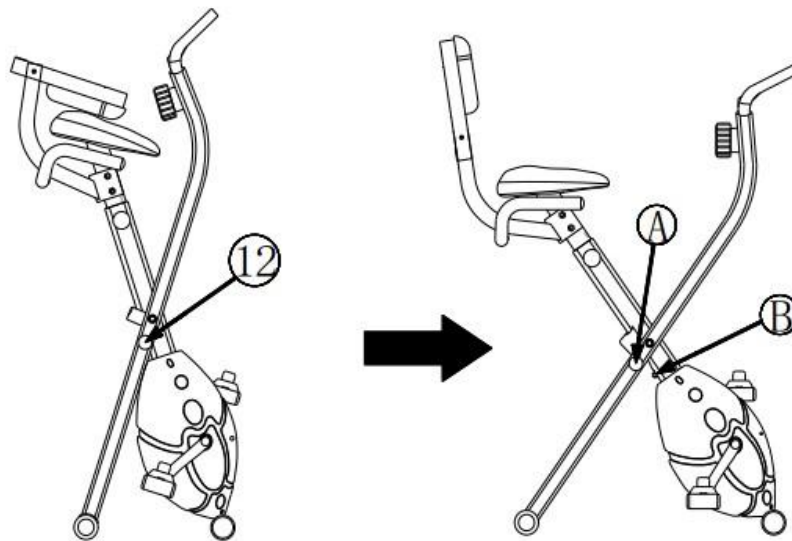

The Saddle Support has "Max" Sign to show the maximum height of Saddle. You should not exceed this height. Unscrew the Seat Adjust Knob (17) first, and then pull the knob outward to release the Seat Support Tube (7). Position the Seat Support Tube to the desired height allowing for a slight bend in the knee at the lowest pedal position and retighten the Seat Adjustment Knob (17).

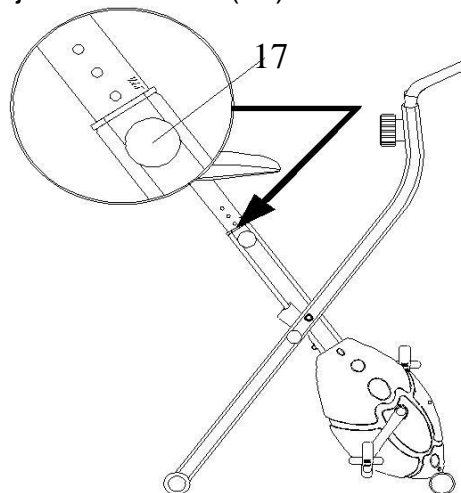

Assembly

HARDWARE LIST

These are all the accessories you will need to complete the assembly of your product. The following accessories are supplied in a pack and should be checked before attempting assembly.

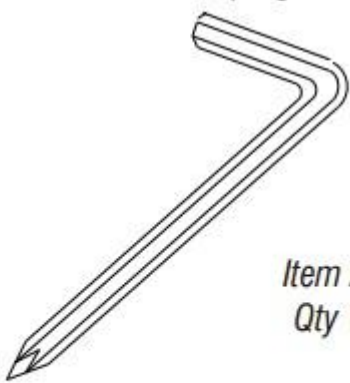

Item 20
Qty 1



Item 13
Qty 4



Item 14
Qty 6



Item 15
Qty 7

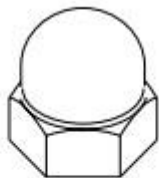

Item 16
Qty 7



Item 18
Qty 4



Item 31
Qty 1

Assembly & Adjustments

1. Unfold the Main Frame (1) and Rear Frame (2). Lock into position using 1 x Locking Pin (12). Connect the Rear Stabilizer (3) to the Rear Frame (2) with 2 x M8 * 55mm Carriage Bolts (13), 2 x M8 Curved Washers (14), 2 x M8 Spring Washers (15) and 2 x M8 Dome Nuts (16). Repeat for the Front Stabilizer and tighten all Nuts and Bolts securely.

2. Assemble the Pedals (Left and Right) (5) to the Pedal Crank (6) (See note below). Both pedals must be tightened securely; otherwise, damage may occur to the Crank.

* NOTE *

The right pedal is marked with an "R" for the RIGHT SIDE of the cycle (if you are sitting on the bike), and must be assembled by turning CLOCKWISE. The left pedal is marked with an "L" for the LEFT SIDE of the cycle (if you are sitting on the bike), and must be assembled by turning COUNTER-CLOCKWISE to tighten.

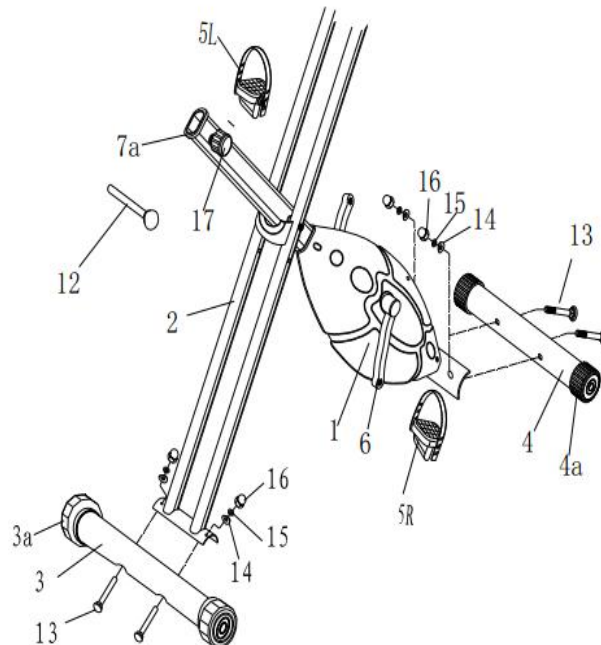

Assembly & Adjustments

3. Remove the 3 x M8 Flat Washers (8a) and 3 x M8 Nylon Locknuts (8b) from the Saddle (8). Fix the Saddle to the Saddle Support (7) and reassemble the washers and nuts previously removed. Unlock the Adjuster Knob (17) and slide the Saddle Support into the Main Frame. Set the Saddle to the desired height, allowing for a slight bend in the knee at the bottom of the cycle rotation. Re-tighten the Adjuster Knob (17).

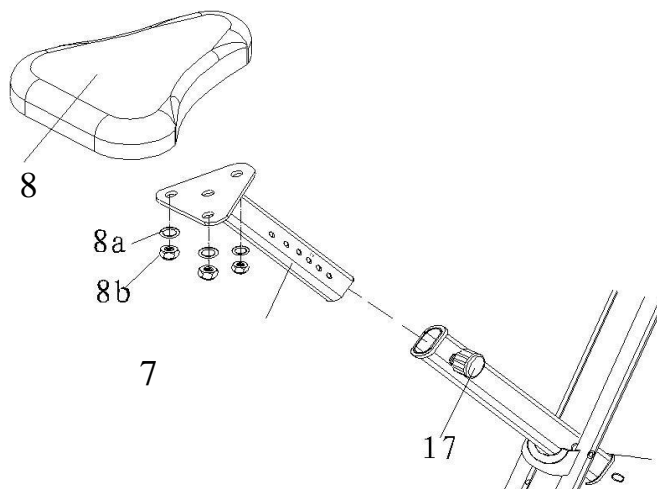

4. Connect the Handlebar (9) to the Handlebar Support using 2 x M8 * 35mm Allen Bolts (18). Attach the Exercise Monitor (10) onto mounting tab on the Handlebar (9). Connect the Sensor Wire (19) with Exercise Monitor (10).

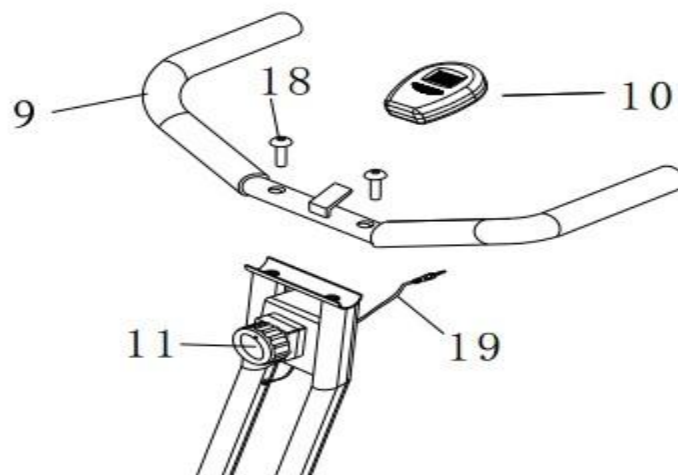

Assembly & Adjustments

5. Connect the Backrest Stem Support (21) to the Saddle support (7) with 2 x M8 Flat Washers (8a) and 2 x M8 Dome Nut (16) and 2 x M8 carriage Bolts (24) and 2xM8 Spring Washer (15).

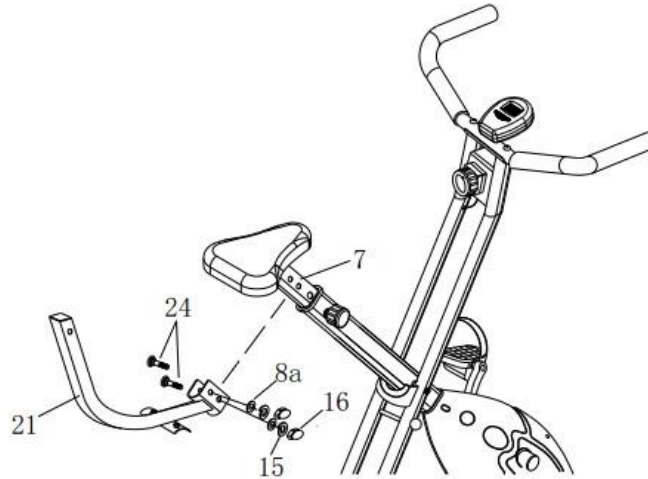

6. Remove 4 x M6 Flat Washers (27) and 4 x M6 Screws (26) from the Backrest Support (23). Fix the Backrest (30) to the Backrest Support (23) and reassemble the washers and nuts previously removed. Attach the Backrest Support (23) to the Backrest Stem Support (21) with M8 Allen Bolt (25), Flat Washer (8a), M8 Spring Washer (15) and M8 Dome Nut (16).

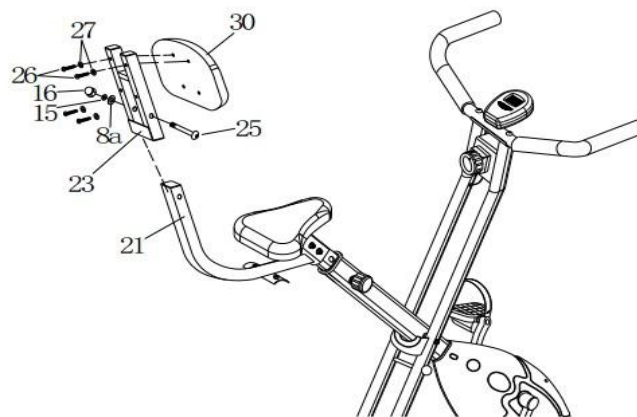

Assembly & Adjustments

7. Connect the Handlebar (22) to the Backrest Stem Support (21) by fastening 2* M8* 35mm Allen Bolts (18) and 2* M8 Curved Washer (14).

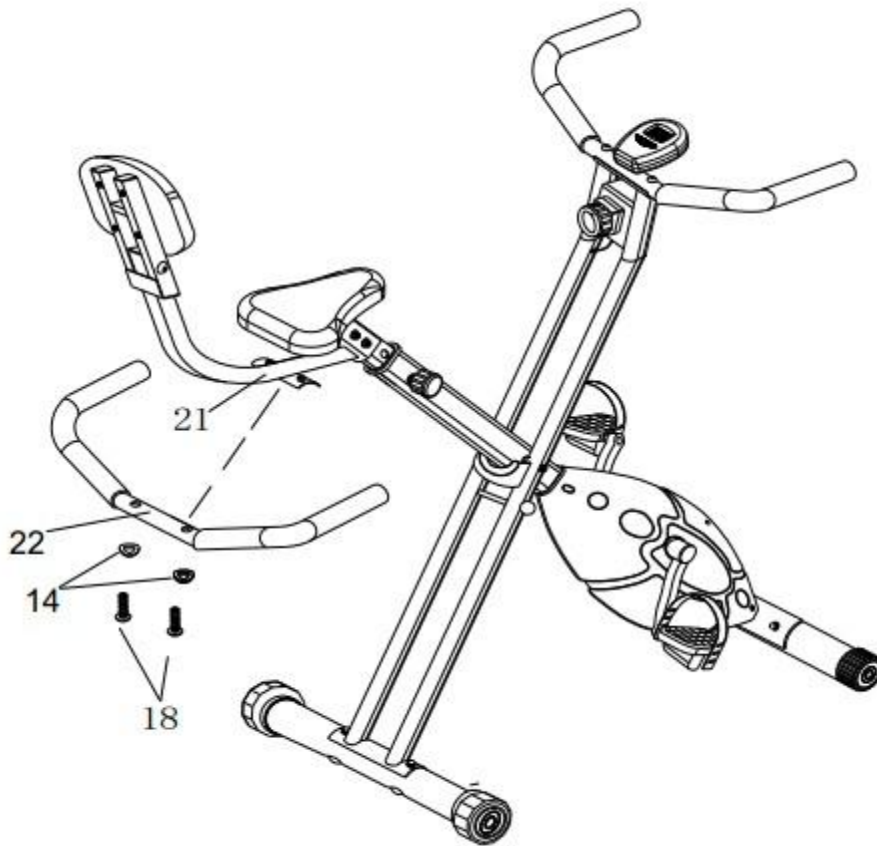

Exploded Diagram

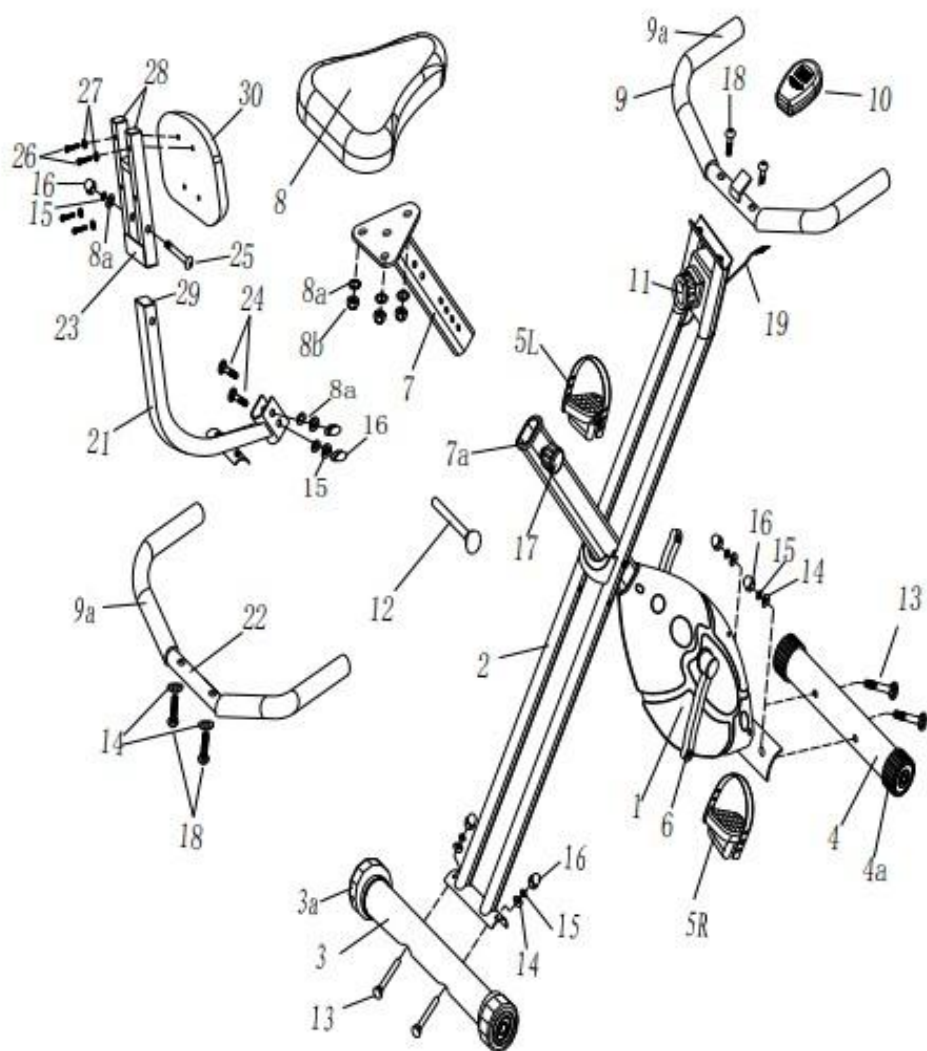

PARTS LIST

Part NO.	DESCRIPTION	QTY
1	Main Frame	1
2	Rear Frame	1
3	Rear Stabilizer	1
3a	Adjustable End Cap	2
4	Front Stabilizer	1
4a	Front End Cap	2
5	Pedal (R & L)	2
6	Crank (R & L)	2
7	Saddle Support	1
7a	Saddle Stem Insert	1
8	Saddle	1
8a	M8 Flat Washer	6
8b	M8 Nut	3
9	Handlebar	1
9a	Handlebar Foam	4
10	Exercise Mointor	1
11	Tension Control	1
12	Locking Pin	1
13	M8*55 mm Carriage Bolt	4
14	M8 Curved Washer	6
15	M8 Spring Washer	7
16	M8 Dome Nut	7
17	Adjuster Knob	1
18	M8*35 mm Allen Bolt	4
19	Sensor Wire	1
20	Allen Key	1
21	Backrest Stem Support	1
22	Handlebar	1
23	Backrest Support	1
24	M8 Carriage Bolt	2
25	M8*75mm Allen Key	1
26	M6 Screw	4
27	M6 Flat Washer	4
28	15*30 Oblong End Cap	4
29	30*30 Square End Cap	1
30	Backrest	1
31	Wrench	1