

- Recessed
- Three Adjustable Shelves
- Reversible **Bradex**[®]

Product Materials

CABINET: 26 gauge steel, one-piece drawn construction finished with rust-resistant, baked-on enamel after forming. Sides formed to support adjustable shelf brackets.

DOOR: heavy-duty steel, finished with rust-resistant, baked-on enamel to match cabinet, equipped with full-length piano hinge with built-in stop, protective door bumpers, and a magnetic catch.

MIRROR: No. 1 quality, distortion-free, 2mm thick float glass, electrolytically copper-backed with full surround stainless steel frame with tab closure. One year warranty.

SHELVES: (3) prepainted metal.

Operation

Cabinet is reversible for left or right hand door swing. Shelves are removable and adjustable.

Installation

Verify all rough-in dimensions prior to installation. Cabinet requires rough wall opening of 14"W x 24"H x 3 3/8"D. Secured to framing with mounting screws (included) through holes provided.

Guide Specification

Recessed medicine cabinet shall be of one-piece, heavy-duty drawn steel construction finished with baked-on enamel after forming. Swing door shall have float glass mirror with full surround stainless steel channel frame with tab enclosure. Cabinet shall be equipped with three adjustable shelves, full length piano hinge, and magnetic catch. Cabinet shall be reversible for left or right hand door swing.

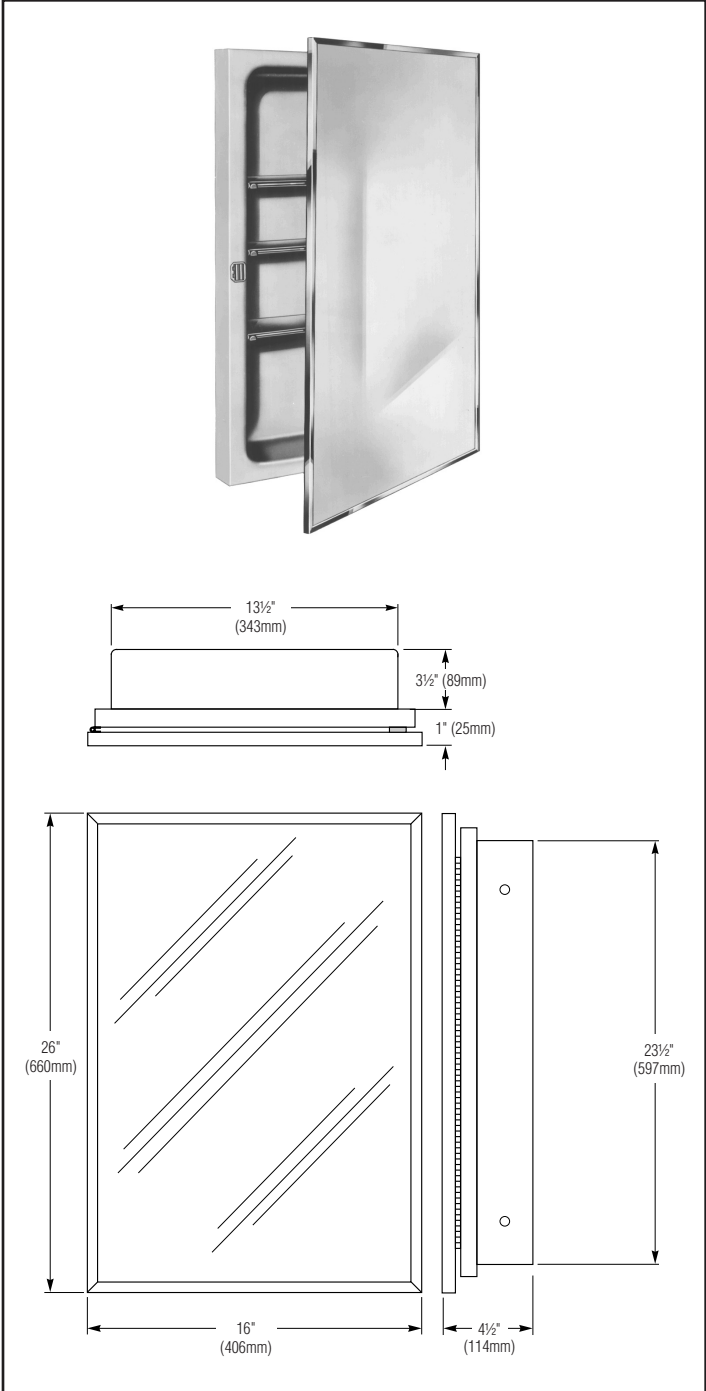

**Washroom Accessories
Document No. 9055**

Orders composed of products indicated as **Bradex**[®] will be available to ship in three days after receipt of order at the factory. There is no pricing penalty for this service from Bradley. This information is subject to change without notice.

Always consult local and national codes for proper installation guidelines. Conformity and compliance to local and national codes is the responsibility of the installer.

3-8-2011

© 2011 Bradley Corporation
P.O. Box 309, Menomonee Falls, WI 53052-0309
Phone: 800.BRADLEY (800.272.3539) Fax: 262.253.4161
bradleycorp.com