

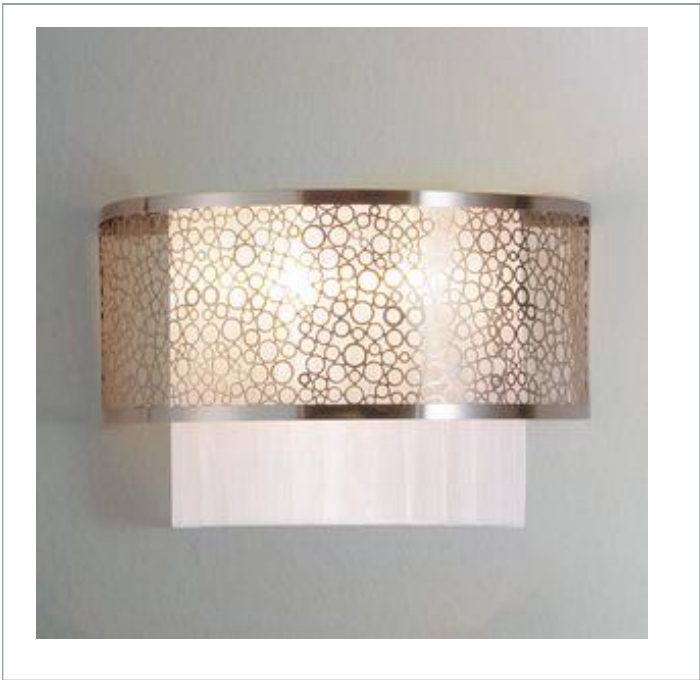



✉ 33 West Beaver Creek Road Richmond Hill
Ontario Canada L4B 1L8
☎ 800.660.5391
📠 800.660.5390
✉ info@eurofase.com
🌐 www.eurofase.com



CALEDON , 2-LIGHT WALL SCONCE

Product Specifications

Collection: Illuminations
Model No.: 17405
Height: 8.5"
Extension: 6.5"
Length: 13"
Est. Shipping Weight: 4.125 lbs
No. of Bulbs: 2
Bulb Wattage: 60 watts
Bulb Type: B10 
Bulb Base: E12
Bulb Voltage: 120 volts

Options Available

ITEM CODE	FINISH	SHADE
17405-010	satin nickel	white

Colour / Shades Available

FINISH	SHADE
satin nickel <input type="radio"/>	white <input checked="" type="radio"/>

A lithe and webbed silvery framework is enshrined within a sharply line satin nickel border. It provides a light yet emphasizing touch to the white pleated drum shade it encases- the zenith of ethereal, weightless lighting.

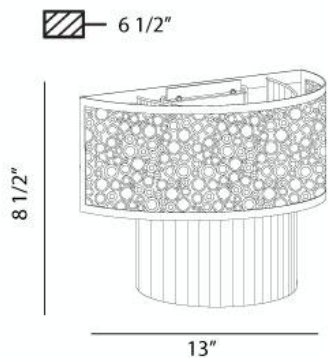

Project Information

Job Name: _____ Date: _____ Type: _____
Comments: _____