

Universal

Universal® Kettlebell Stand

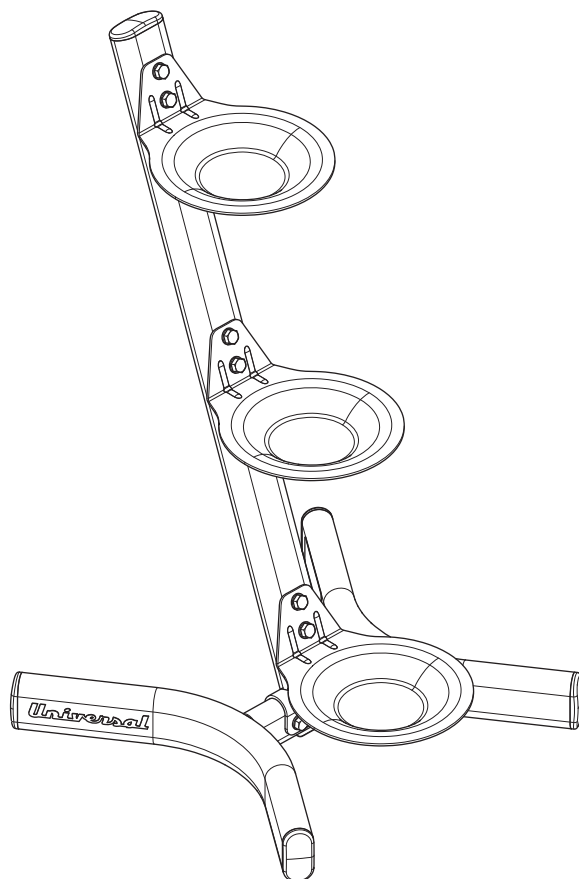

Assembly Manual



Ver página 2

Español Americano Latino

Nautilus®

Bowflex®

Schwinn® Fitness

Universal®

Table of Contents

Important Safety Instructions	3
Specifications	4
Before You Start	4
Parts & Hardware	5
Assembly	6
Maintenance	8
Contacts	9

To register your product for Warranty support please visit: www.UniversalHomeFitness.com/Register

Important Safety Instructions



This icon means a potentially hazardous situation which, if not avoided, could result in death or serious injury.

Before using this equipment, obey the following warnings:



Read and understand the complete Assembly manual.

Read and understand all Warnings on this machine.

- Keep children away from this machine. Monitor them closely when near the machine. Moving parts that look dangerous to adults may not look so to children.
- Consult a physician before starting an exercise program. Stop exercising if you feel pain or tightness in your chest, become short of breath, or feel faint. Contact your doctor before using the machine again.
- Examine this stand for loose parts or signs of wear. Tighten or replace any worn or loose components before use. Examine all fasteners carefully. Contact Nautilus® Customer Service for repair information.
- This machine is for home use only.
- Set up and operate the stand on a hard, level surface.
- Do not wear loose clothing or jewelry while exercising.
- Do not exercise with more resistance than you can physically handle. We recommend you train with an exercise partner or spotter.
- This product, its packaging, and components contain chemicals known to the State of California to cause cancer, birth defects, or reproductive harm. This Notice is provided in accordance with California's Proposition 65. If you would like additional information, please refer to our Web site at www.nautilus.com/prop65

Specifications

Assembled Dimensions: 16.5”L x 16.75”W x 28.7”H

Assembled Unit Weight: 12.2 lbs.

Packaged Shipping Weight:

Large Kit: 62 lbs.

Small Kit: 39.16 lbs.

Before You Start

Follow these basic assembly tips when putting your bench together:

1. Collect all the pieces required for each step before assembling.
2. Turn bolts and nuts to the right to tighten, and the left to loosen.
3. Lightly and carefully lift pieces when attaching. Look through the bolt holes to help guide bolts through the holes.

Tools (not included)



6mm



14mm

Parts

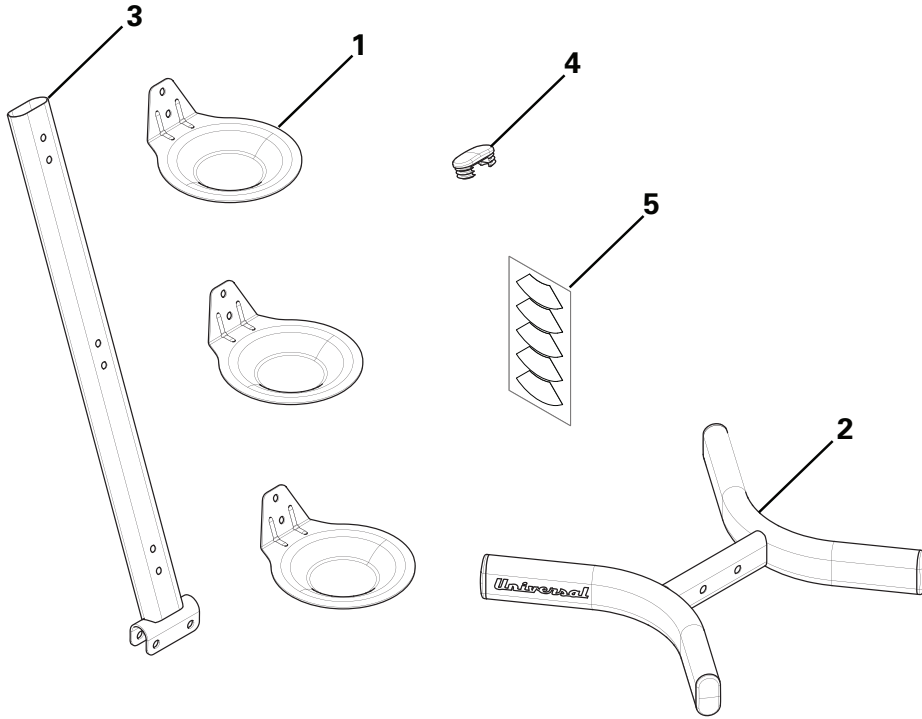

Item	Qty	Description
1	3	Tray
2	1	Base
3	1	Upright
4	1	End Cap
5	5	Weight Tray Stickers

Hardware

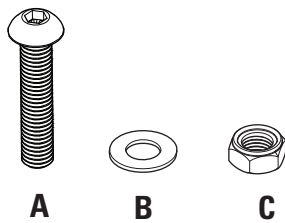

Item	Qty	Description
A	8	Bolt (M8)
B	16	Flat Washer (M8)
C	8	Nut (M8)

Assembly

Step 1: Attach Upright to Base

Note: Place base on floor with logo's oriented as shown.

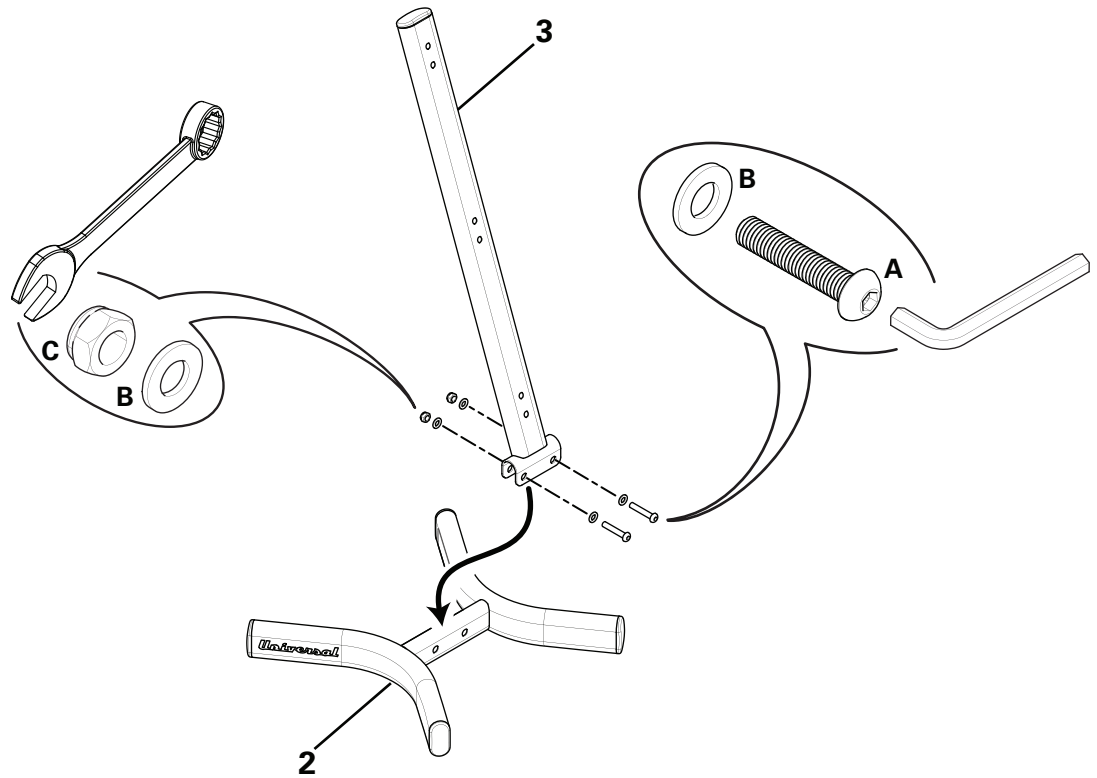

Step 2: Attach Trays to Upright

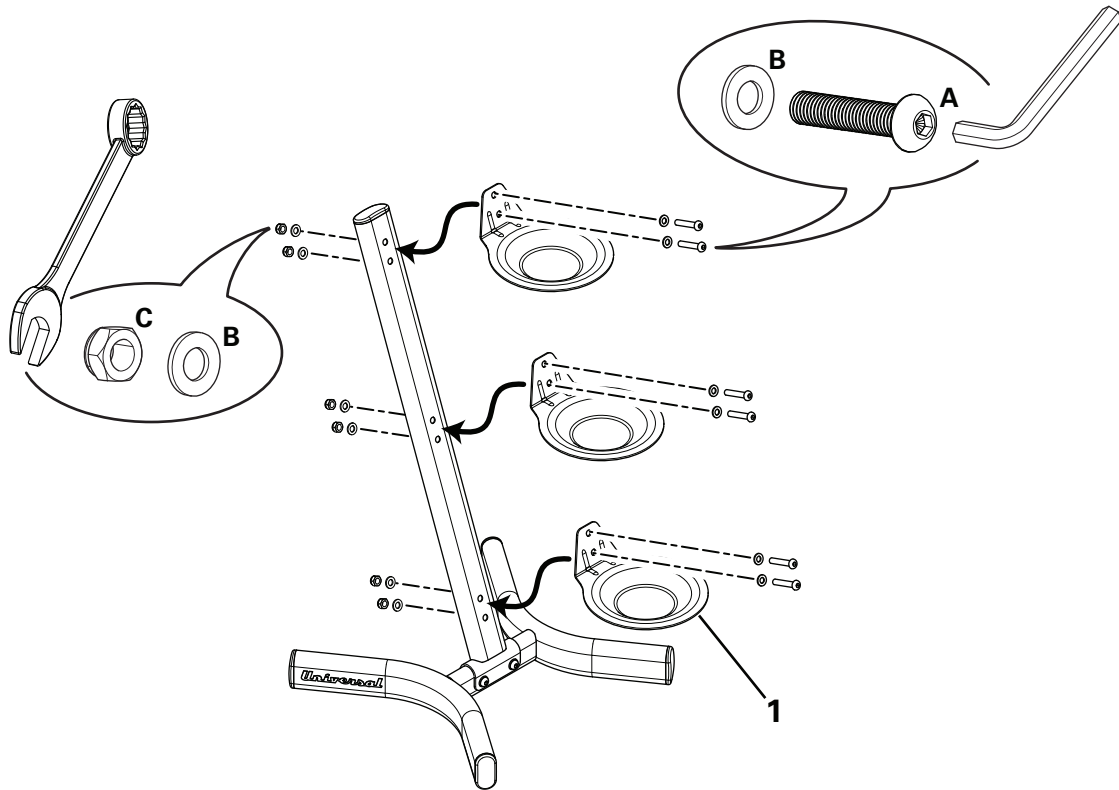

Assembly

Step 3: Place Weight Tray Stickers to Trays. Lightest weight on top tray.

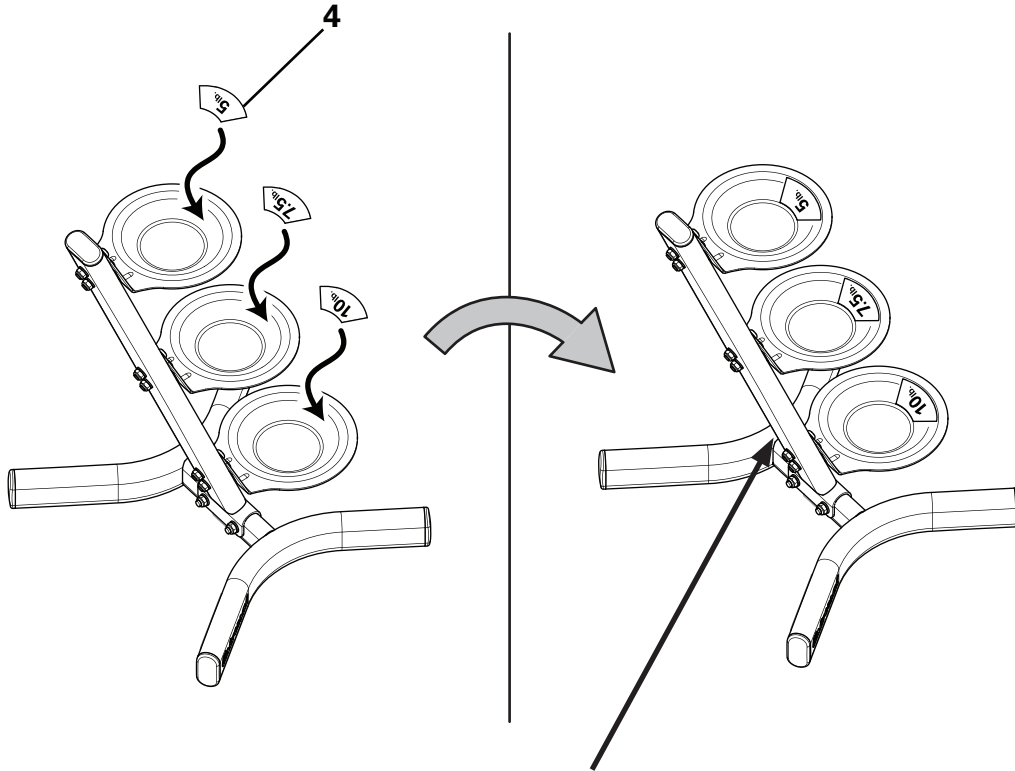

Serial Number
Date of Purchase

Maintenance

The safety and performance of this product can be maintained only if it is examined regularly for damage and wear.



Examine the equipment before each use for damage and wear. Replace broken components immediately or put the equipment out of use until repaired.

Daily/Before Each Use: Examine machine. Make sure it looks in good condition and operates smoothly. If you find damage, DO NOT USE. Contact your authorized Nautilus® Fitness Dealer for servicing.

Daily/After Each Use: Clean machine with a clean, dry cloth. Use a mild detergent or spray cleaner on upholstery. Do not use cleansers containing enzymes.

Weekly: Clean machine fully with a clean cloth and ammonia-based cleaner. Touch up any scratches with touch-up paint to prevent rust, if necessary.

Monthly: Examine the frame for signs of cracking or permanent bending. Do not use the equipment if you see this. Contact Nautilus® Service immediately.

If you have any questions on the correct use or maintenance of this equipment, call your authorized distributor or Nautilus® Customer Service located on the Contacts page of this manual.

Contacts

NORTH AMERICA

CUSTOMER SERVICE

Tel: (800) 605-3369

E-mail: csnls@nautilus.com

CORPORATE HEADQUARTERS

Nautilus, Inc.

World Headquarters

16400 SE Nautilus Drive

Vancouver, Washington, USA 98683

Phone: (800) NAUTILUS (800) 628-8458

ASIA PACIFIC & LATIN AMERICA

CUSTOMER SERVICE

Tel: (360) 859-5180

Fax: (360) 859-5197

E-mail: technics-APLA@nautilus.com

EUROPE, MIDDLE EAST & AFRICA

INTERNATIONAL CUSTOMER SERVICE

Nautilus International GmbH

Albin-Köbis-Str. 4

51147 Köln

Tel: + 49 02203 2020 0

Fax: + 49 02203 2020 45 45

E-mail: technics-EMEA@nautilus.com

GERMANY and AUSTRIA

Nautilus International GmbH

Albin-Köbis-Str. 4

51147 Köln

Tel: + 49 02203 2020 0

Fax: + 49 02203 2020 45 45

UNITED KINGDOM

Nautilus UK Ltd

4 Vincent Avenue

Crownhill, Milton Keynes, Bucks, MK8 0AB

Tel: + 44 1908 267 345

Fax: + 44 1908 267 345

Universal

Printed in China

© 2009 Nautilus, Inc., All rights reserved

™ and ® indicate a trademark or registered trademark. Nautilus, Inc. (www.nautilus.com) trademarks include NAUTILUS®, BOWFLEX®, SCHWINN® and UNIVERSAL® and respective logos. Other trademarks are the property of their respective owners.

Nautilus®

Bowflex®

Schwinn® Fitness

Universal®