

Features

- For use with Aquifer water filtration system.
- Single-stage filtration and absorption system.
- Filter reduces particulates, sediments, rust, cysts, and chlorine taste and odor.
- Cartridge filter can be twisted in and out for easy replacement.



Codes/Standards

NSF 42

NSF 53

All applicable US Federal and State material regulations

KOHLER® One-Year Limited Warranty

See website for detailed warranty information.

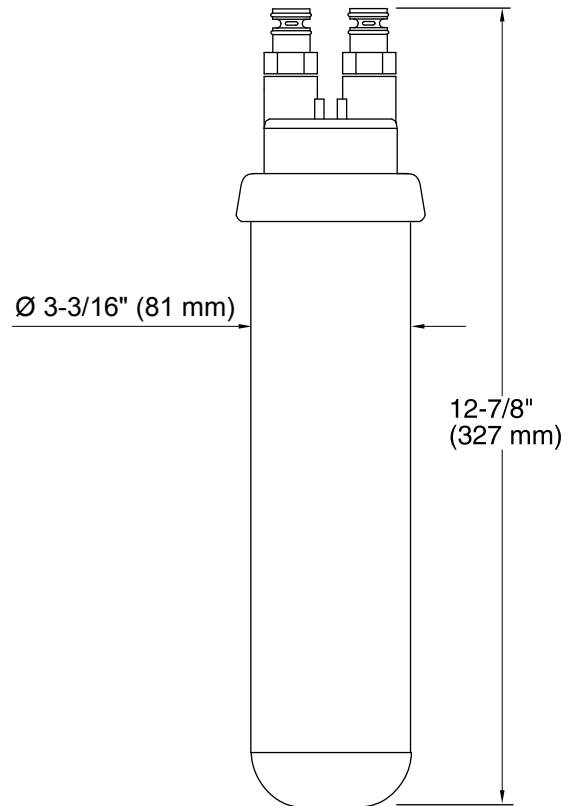

Technical Information

All product dimensions are nominal.

Faucet:

Flow rate: 1.5 gal/min (5.7 l/min)

Notes

Install this product according to the installation guide.

For cold water use only.

Application guideline/water supply parameters:

Pressure 30 – 125 psi (862 kPa)

Temperature 40° - 100° F (4.4° - 38° C)

Capacity: 1,500 gal (5,678 L)