

G97300, G97301 Roll Top Desk - Chair Assembly Instructions

For ages 3 and up. Adult assembly required.

▲ WARNING

Small parts and sharp points may be present prior to assembly.

Care Instructions

To clean your product, use mild soap and water on a damp cloth. Do not use window cleaners or cleaning abrasives as they will scratch the surface and could damage the protective coating.

Customer Service

For questions regarding this product, or to receive replacement or missing parts, contact Customer Service at (800) 524-3555. Please have the model number and part number(s) located in this Assembly Instruction sheet available for reference.

Limited Warranty

All Guidecraft products are warranted to the original purchaser at the time of purchase and for a period of one (1) year thereafter. In order to provide you with timely assistance, please thoroughly inspect your product for missing or defective parts immediately after opening the carton. To receive replacement or missing parts under this warranty, contact Customer Service. You will also need your sales receipt or other proof of purchase.

Hardware

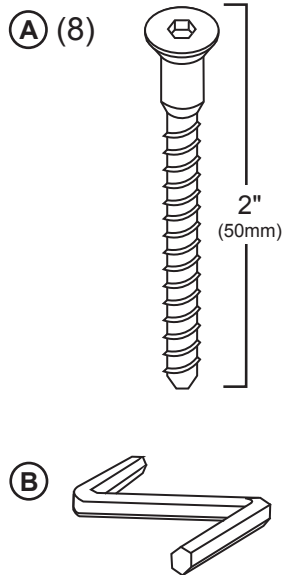

Assembly

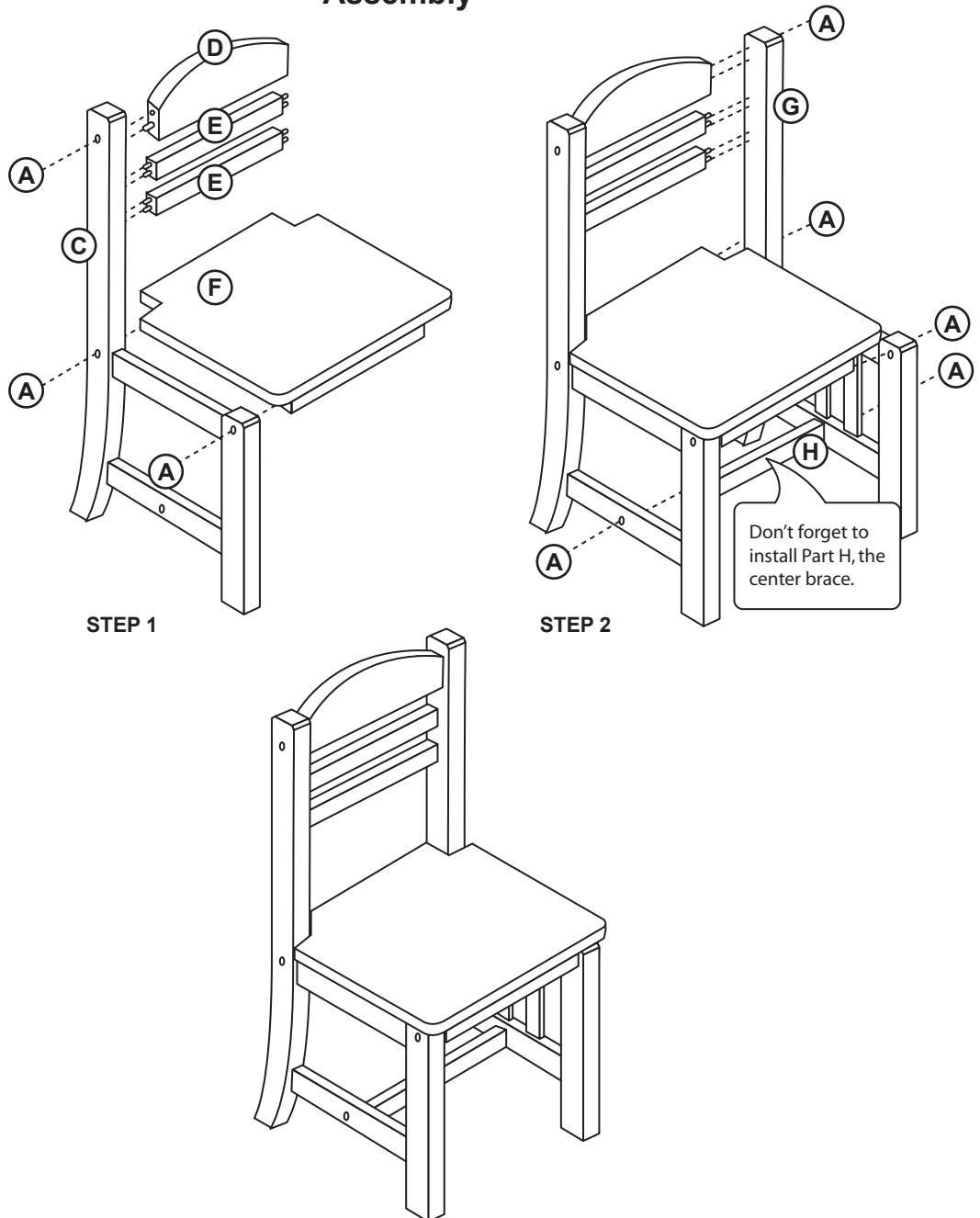



G97300, G97301 Roll Top Desk Assembly Instructions

For ages 3 and up. Adult assembly required.

▲ WARNING

Small parts and sharp points may be present prior to assembly.

Care Instructions

To clean your product, use mild soap and water on a damp cloth. Do not use window cleaners or cleaning abrasives as they will scratch the surface and could damage the protective coating.

Customer Service

For questions regarding this product, or to receive replacement or missing parts, contact Customer Service at (800) 524-3555. Please have the model number and part number(s) located in this Assembly Instruction sheet available for reference.

Limited Warranty

All Guidecraft products are warranted to the original purchaser at the time of purchase and for a period of one (1) year thereafter. In order to provide you with timely assistance, please thoroughly inspect your product for missing or defective parts immediately after opening the carton. To receive replacement or missing parts under this warranty, contact Customer Service. You will also need your sales receipt or other proof of purchase.

Hardware and Parts

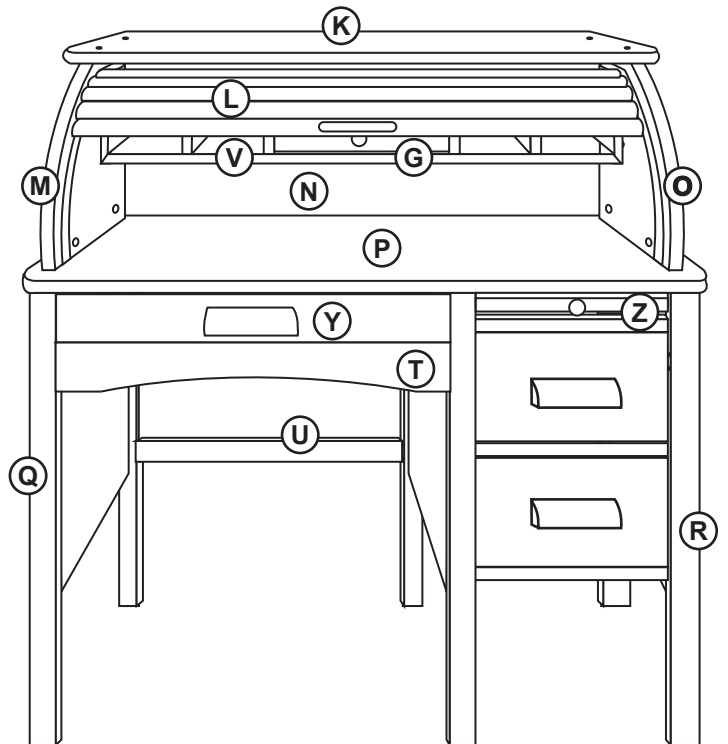
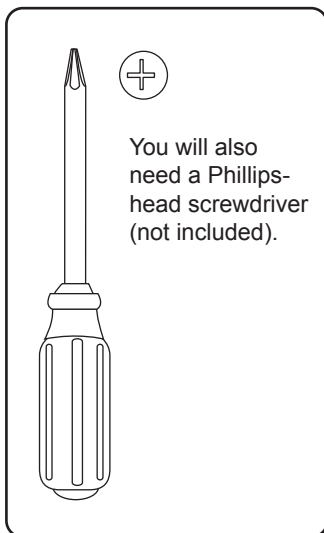
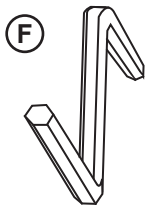
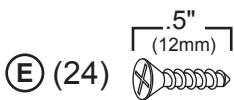
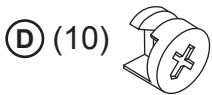
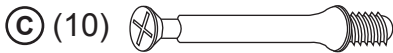
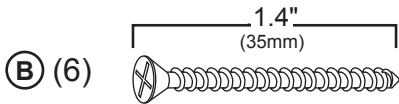
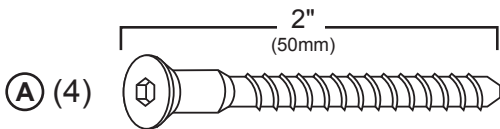

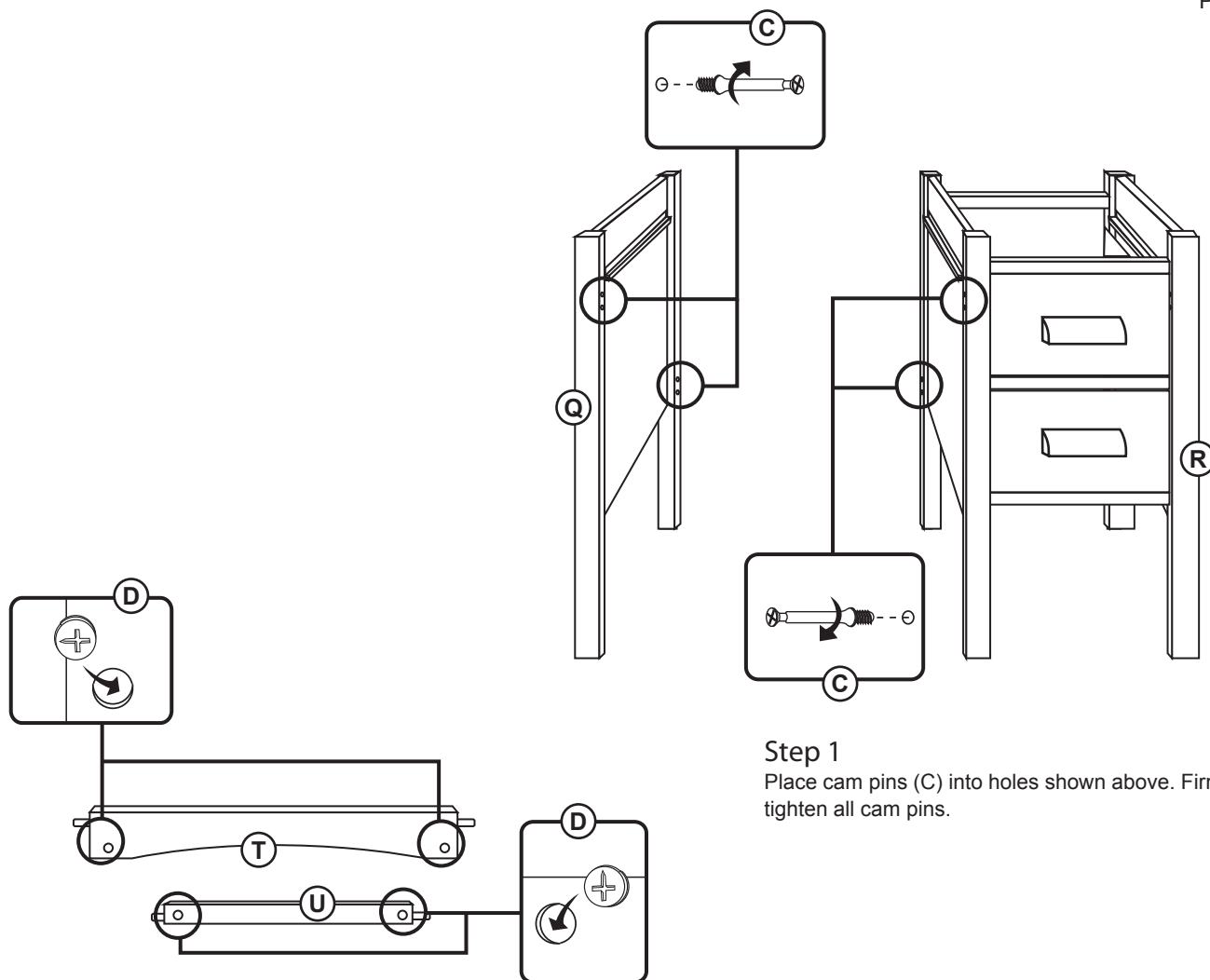

Step 1
Place cam pins (C) into holes shown above. Firmly tighten all cam pins.

Step 2
Place cam nuts (D) into holes on Parts T and U so that the arrow on the cam face is lined up with the opening.

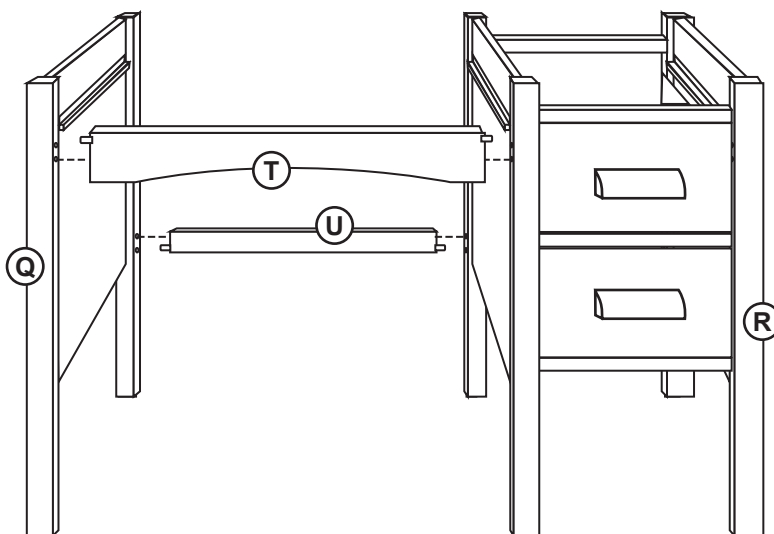

Step 3
Once Parts T and U are attached to Parts Q and P, tighten cam nuts by turning clock-wise until they've locked into place.

Step 4

Place cam pins (C) into holes shown below. Firmly tighten both cam pins.

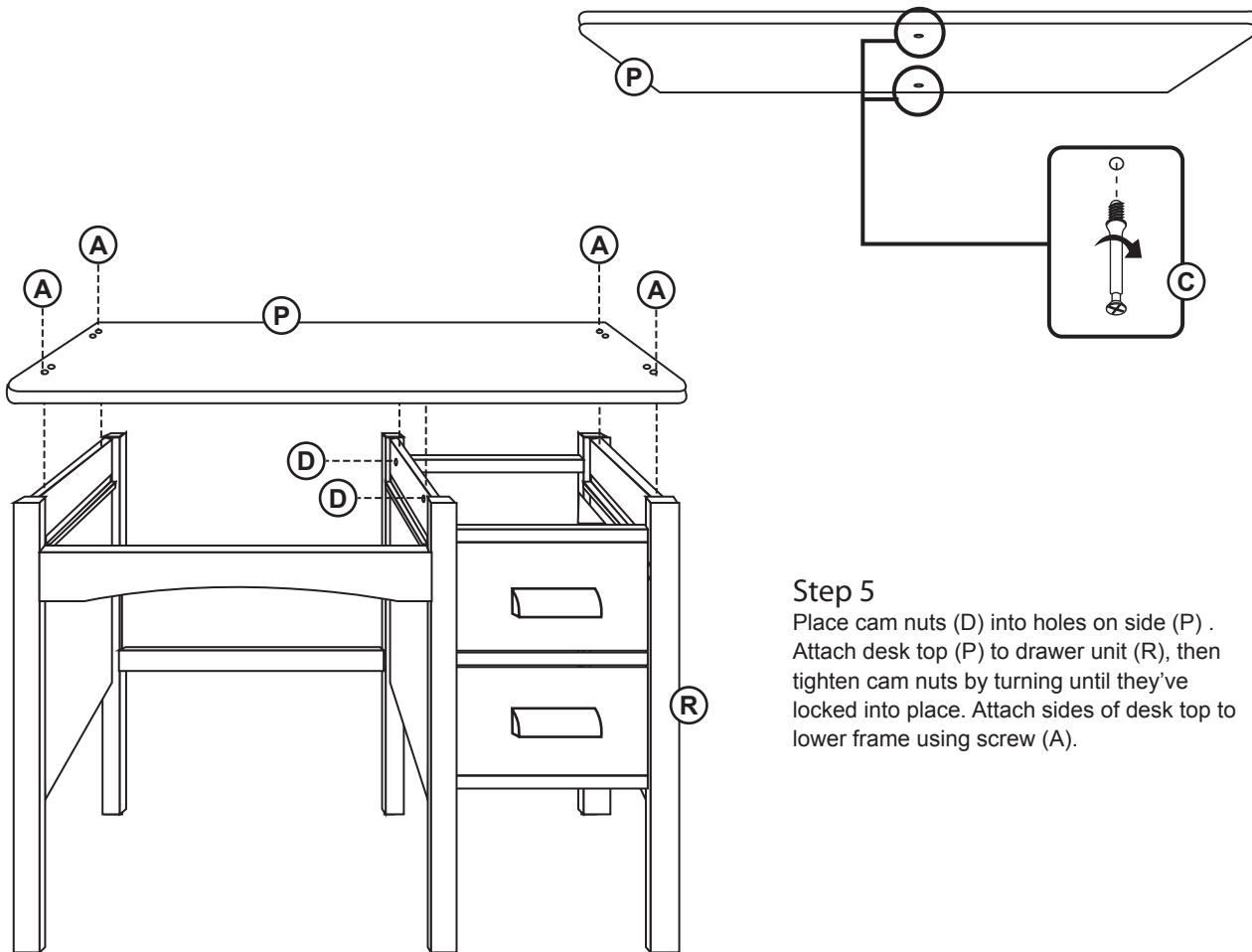

Step 5

Place cam nuts (D) into holes on side (P). Attach desk top (P) to drawer unit (R), then tighten cam nuts by turning until they've locked into place. Attach sides of desk top to lower frame using screw (A).

Step 6

Attach roll top sides (M and O) to desk top (P), using cam pins (C) and cam nuts (D).

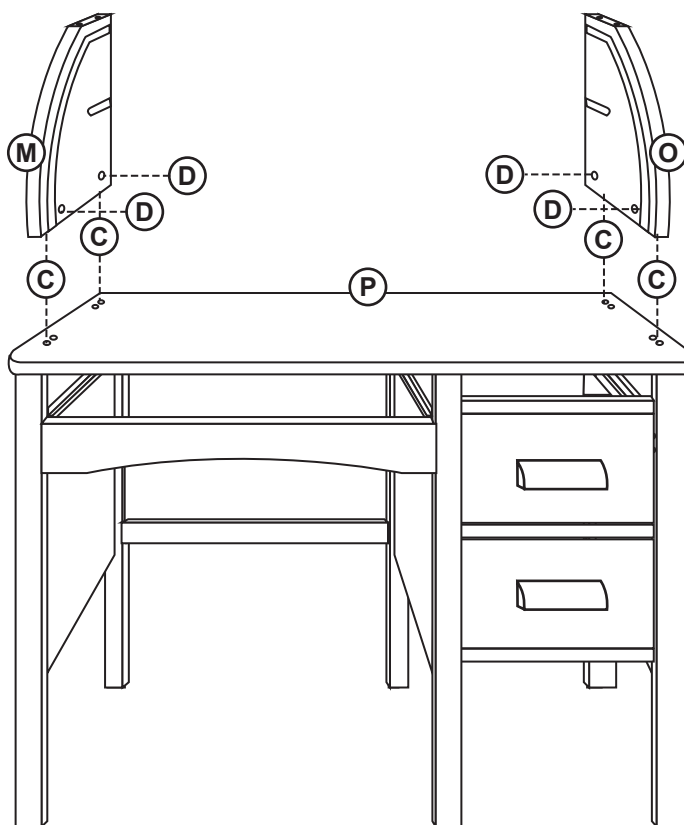

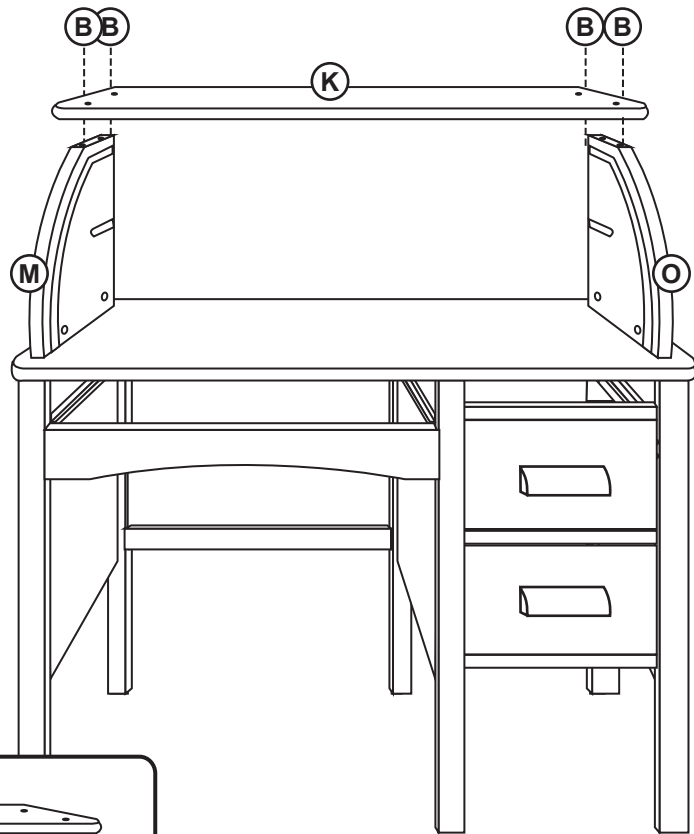

Step 7

Attach top (K) to roll top sides (parts M and O) using screw (B).

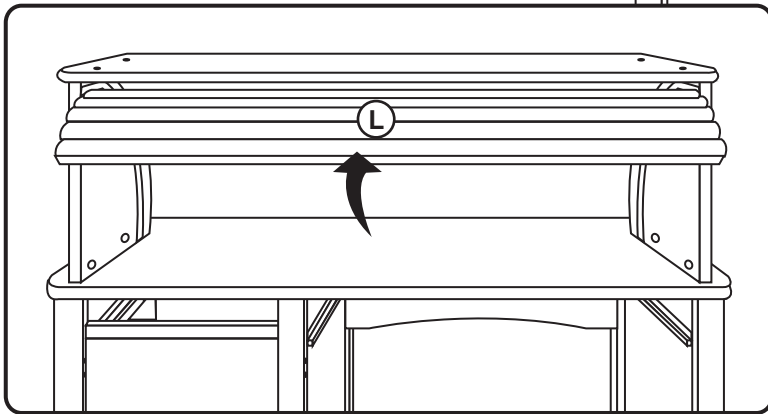

Step 8

From the back of the unit, insert roll top slats (L) into grooves in the roll top sides. Make sure handle cutout (indentation) on the front-most slat ends up on the front of the desk.

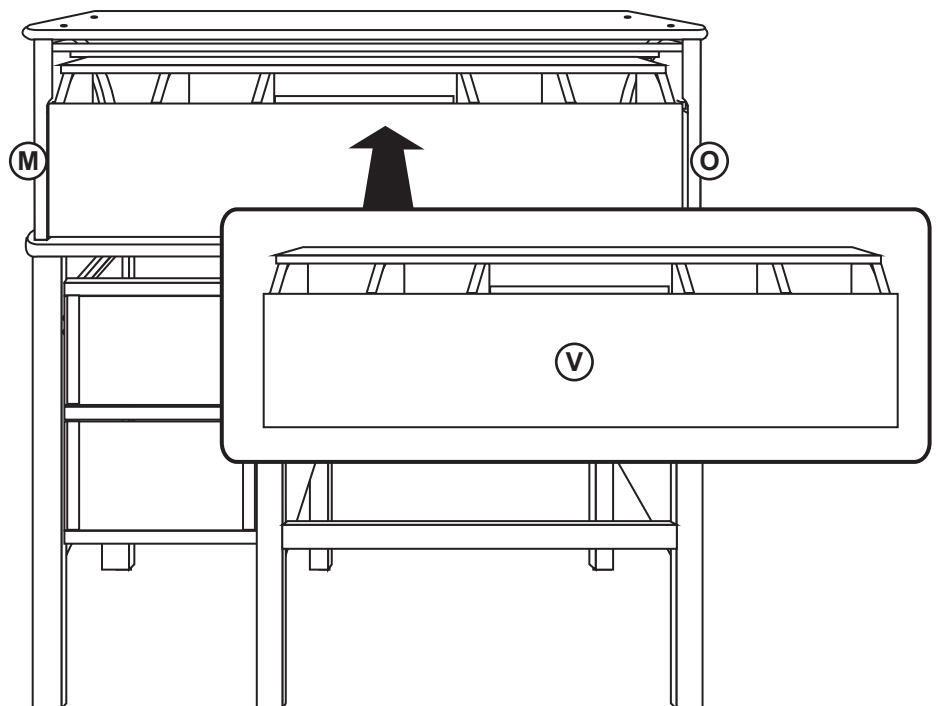

Step 9

Insert storage compartment (V) from back of unit. Ensure the brackets on the sides of the storage compartment unit slip into the grooves on the roll top sides (M and O).

Step 10

Insert desk drawer (Y) from the front of the unit. From the back of the unit, screw drawer tipping bracket (X) to back of drawer (Y) using screws (B).

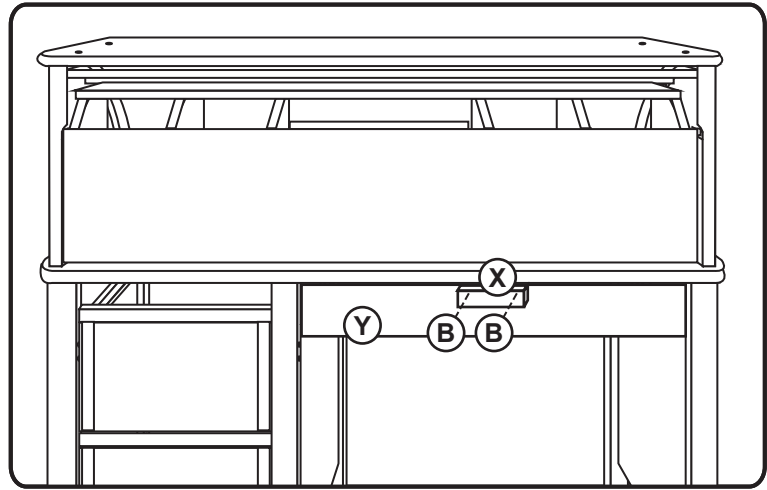

Step 11

Attach back panels W and S using screws (E). When completed, insert the pull-out tray (Z) in the front section and the small drawer (G) in the storage compartment.

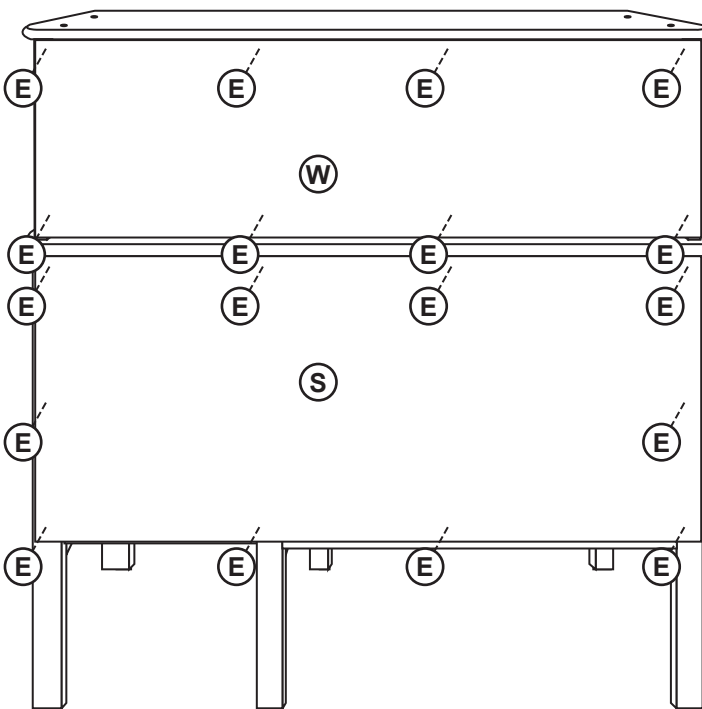

Step 12

Insert the pull-out tray (Z) in the front section and the small drawer (G) in the storage compartment.

Roll Top Slat

If at any time the pull-down slats of the roll top desk stick in the grooves, or become hard to open and close, rub a small amount of hand soap (Ivory soap or similar) in the channels. Soap will not damage the wood and will ensure a smooth opening and closing of the roll top slats.

