

ASSEMBLY INSTRUCTIONS



© 2008 Graco Children's Products Inc.
GRACO is a registered trademark of
Graco Children's Products Inc., used with permission.

CONVERTIBLE CRIB

Adult assembly required.
Small parts may present a choking hazard prior to assembly.

Enclosed please find simple step-by-step instructions to help you quickly assemble your product. Before you begin we recommend that you follow the steps below:

1. Please read the instructions thoroughly
2. Identify all parts and hardware
3. You may need to provide the following tools:
Philips Head screw driver
Flat head screw driver
Hammer.

⚠ Do Not Use Power Drills or Drivers

To protect your parts during assembly please place them on a soft surface. To clean surface use only water on a damp cloth. Do not use window cleaners or cleaning abrasives as it will scratch the surface and could damage the protective coating.

PARTS LIST

REF.	PART NAME	QUANTITY
A.	Back Rail Top	1
B.	Crib Ends	2
C.	Left and Right Back Legs	2
D.	Back Rail Bottom	1
E.	Front Rail	1
F.	Bottom Stretcher Bar	1
G.	Metal Spring Support Platform	1
H.	3" Allen head Bolt	4
I.	2-1/2" Allen head Bolt	12
J.	1-1/2" Allen head Bolt	2
K.	3/4" Allen head Bolt	4
L.	Barrel Nuts	16
M.	Allen Wrench	1
N.	1-1/8" Wood Dowel	2

Model shown

04530-651, 04530-654,
04530-659, 04530-65B,
04530-661, 04530-664,
04530-669, -4530-66B

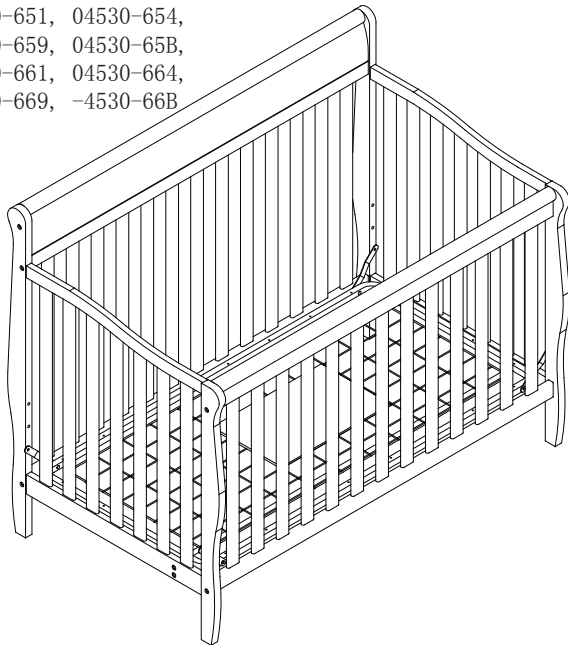

HARDWARE AND TOOL DIAGRAM

(H) 3" Allen head Bolt

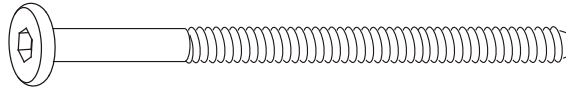

(I) 2-1/2" Allen head Bolt

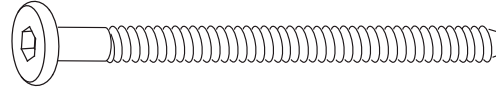

(J) 1-1/2" Allen head Bolt

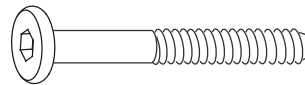

(K) 3/4" Allen head Bolt

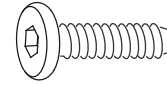

(L) Barrel Nuts



(M) Allen Wrench

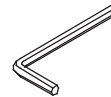

(N) 1-1/8" Wood Dowel



PRINTED IN CHINA

Furniture Care Instructions

Room Climate Control

Wood, when first cut contains more than 50 percent water. When it is prepared for furniture construction it is placed in a Kiln and the moisture content is brought down to 8 to 10 percent. Wood is porous and responds to its environment. If the room has high humidity it will absorb it and expand and if the humidity is low it will lose moisture and shrink.

It is important that the humidity levels in the room be controlled from extremes of too much humidity or too little. Furniture should not be placed close to air-conditioning outlets, fire places, radiators, space heaters, humidifiers or dehumidifiers. Exposure to extreme variations of temperature and humidity can damage any fine wood product.

The Ideal Environment for Fine Furniture

Fine wood furniture will have fewer problems when its environment is controlled at a temperature between 65 and 75 degrees fahrenheit and a relative humidity between 35 and 40 percent .Wood placed in an environment outside of those limits can and will shrink or expand and may develop some small cracks which are not material or structural defects.

Sticking Doors and Drawers

With the minor changes in temperature and humidity doors and drawers may swell and be difficult to open or close. Tolerances have been built into the units but extreme conditions may still cause sticking. This will adjust back to normal over time but until it does consider using a dehumidifier or rub candle wax or paraffin on the sides that stick.

Avoid Direct Sunlight

Keep the furniture out of direct sunlight. Ultraviolet rays will fade colors and in some cases darken them. It can also cause crazing or hair line cracks in the finish. White finishes will yellow naturally over time and exposure to direct sunlight will hasten this natural process along with some woods darkening naturally over time; this is not considered to be a quality defect.

Proper Storage

If you need to put your furniture in storage for any period of time do not store them in a damp basement or hot dry attic. Allow air movement around the furniture and do not stack anything on it.

In General

- Protect furniture surface from hot or extremely cold items.
- Use coasters under hot or cold beverages
- Do not use synthetic fabric under accessories or lamps
- Protect tops from pens, markers and crayons
- Oils from potpourri and other scented items can damage the furniture finish.
- Do not drag items across the surface of the furniture.
- Allow the surface to breath by rotating your accessories and lamps.
- Do not over polish the furniture, do it only two or three times a year. Over polishing can distort the natural finish of the product.
- Do not wax the furniture as wax build up can destroy the natural finish of the product.
- When moving furniture always lift the unit. Do not push or drag it to avoid damage to legs
- Keep the furniture level so doors and drawers open and close freely.
- Clean with a damp, not wet, cloth. Use only a mild soap. Do not use abrasive cleaners.

Attention Customers living in the United States and Canada

If you are missing parts, hardware, or if your product has been damaged during shipping,

DO NOT RETURN YOUR PRODUCT

The store does not stock parts and may not be able to help you.

Contact Stork Craft directly and **we will ship you the parts** you need to your shipping address **at no cost to you.** We have three convenient ways for you to reach us:

- Visit us at www.storkcraft.com to order parts online
- Email us at parts@storkcraft.com
- Call us toll free from the USA or from Canada at 1-877-274-0277, Monday to Friday from 7am – 3pm (Pacific Time)

Atención cliente de Canada y de los Estados Unidos

En casos de piezas y/o ferretería faltante o daño debido al transporte, por favor

NO REGRESAR EL ARTÍCULO

El almacene no cargan piezas de reemplazo y posiblemente no podrían ayudar.

Por favor contactar Stork Craft directamente y nosotros les **mandaremos las piezas** requeridas **sin costo alguno** directamente a su domicilio. Contáctenos de las siguientes tres maneras:

- Visitándonos al sitio internet www.storkcraft.com para pedir sus piezas
- Por correo electrónico parts@storkcraft.com
- Por teléfono sin cargo desde el Canada y los Estados Unidos al 1-877-274-0277 del Lunes al Viernes de las 7am hasta las 3pm (hora del Pacifico)

Avis aux clients du Canada et des États Unis

Au cas de pièces ou quincaillerie manquantes, ou d'endommagement durant l'envoi, veuillez

NE PAS RETOURNER L'ARTICLE

Le magasin n'entrepose aucune pièce de rechange et pourrait ne pas pouvoir vous aidez.

Veuillez contactez Stork Craft directement et **nous vous enverrons les pièces** requise **sans frais** a votre domicile. Vous pouvez nous rejoindre à l'aide des trois manières suivante :

- Visiter nous a www.storkcraft.com pour commander vos pièces
- Par courrier électronique a parts@storkcraft.com
- Par téléphone au numéro sans frais au Canada et aux États Unis 1-877-274-0277, du Lundi au Vendredi de 7 :00 hrs. á 15 :00 hrs. (Heure du Pacifique)

Product Assistance Procedures

You have purchased a quality piece of furniture. Our international team has spent many hours designing and engineering this piece and packaging to ensure you will be satisfied with your purchase. But if for any reason you need help with your purchase please contact us at any time.

Procedures to follow should you have any questions:

Most inquiries can be answered by visiting our website **www.storkcraft.com** There you can order parts, find assembly instructions, and get answers to frequently asked questions on all of our brands.

You can also email us at parts@storkcraft.com

In order for us to provide you with the best service possible, please include the following information in your email:

1. Your Name
2. Address
3. Phone Number
4. Item Number and description of your product
5. PO#
6. Production Date

All product information will be on the product label located on the back of all dressers and other furniture, and on either the inside bottom of the headboard, crib ends, or stabilizer bar of your crib, depending on which model you have.

Someone will contact you via e-mail or phone to help you with your issues.

If you do not have internet access, you can fax your information to 604 274 9727.

If you do not have internet or fax access, the please call us toll free at 1-877-274-0277. Be sure to have all of the above information ready to give to your Client Service Specialist.

WARNING

FAILURE TO FOLLOW THESE WARNINGS AND THE ASSEMBLY INSTRUCTIONS COULD RESULT IN SERIOUS INJURY OR DEATH.

- READ ALL INSTRUCTIONS BEFORE ASSEMBLING THE CRIB. KEEP INSTRUCTIONS FOR FUTURE USE.
- INFANTS CAN SUFFOCATE ON SOFT BEDDING. NEVER ADD A PILLOW OR COMFORTER. NEVER PLACE ADDITIONAL PADDING UNDER AN INFANT.
- THE MATTRESS USED IN THIS CRIB SHOULD NOT BE MORE THAN 6 INCHES (15CM.) THICK AND SHOULD BE OF SUCH LENGTH AND WIDTH THAT THE GAP BETWEEN THE MATTRESS AND THE SIDES OF THE CRIB IS NOT MORE THAN 1-3/16 INCHES (3CM.) WHEN THE MATTRESS IS PUSHED INTO THE CORNER OF THE CRIB.
- INFANTS CAN SUFFOCATE IN GAPS BETWEEN CRIB SIDES AND A MATTRESS THAT IS TOO SMALL.
- CHECK THIS PRODUCT FOR DAMAGED HARDWARE, LOOSE JOINTS, LOOSE BOLTS OR OTHER FASTENERS, MISSING PARTS OR SHARP EDGES BEFORE AND AFTER ASSEMBLY AND FREQUENTLY DURING USE. SECURELY TIGHTEN LOOSE BOLTS AND OTHER FASTENERS. DO NOT USE THE CRIB IF ANY PARTS ARE MISSING, DAMAGED OR BROKEN. CONTACT STORK CRAFT FOR REPLACEMENT PARTS AND INSTRUCTIONAL LITERATURE IF NEEDED. DO NOT SUBSTITUTE PARTS.
- TO REDUCE THE RISK OF SIDS, PEDIATRICIANS RECOMMEND HEALTHY INFANTS BE PLACED ON THEIR BACKS TO SLEEP, UNLESS OTHERWISE ADVISED BY YOUR PHYSICIAN.
- **DO NOT** USE A WATER MATTRESS WITH THIS CRIB.
- NEVER USE PLASTIC SHIPPING BAGS OR OTHER PLASTIC FILM AS MATTRESS COVERS BECAUSE THEY CAN CAUSE SUFFOCATION.
- IF RE-FINISHING, USE NON-TOXIC FINISH SPECIFIED FOR CHILDREN'S PRODUCTS.
- **DO NOT** USE THIS CRIB IF THE ATTACHED OR ENCLOSED INSTRUCTIONS CANNOT BE STRICTLY ADHERED TO.
- FOLLOW WARNINGS ON ALL PRODUCTS IN A CRIB.

STRANGULATION HAZARD

- STRINGS CAN CAUSE STRANGULATION! DO NOT PLACE ITEMS WITH A STRING AROUND A CHILD'S NECK, SUCH AS HOOD STRINGS OR PACIFIER CORDS. DO NOT SUSPEND STRINGS OVER A CRIB OR TODDLER BED FOR ANY REASON OR ATTACH STRINGS TO TOYS.
- TO HELP PREVENT STRANGULATION TIGHTEN ALL FASTENERS. A CHILD CAN TRAP PARTS OF THE BODY OR CLOTHING ON LOOSE FASTENERS.
- **DO NOT** PLACE CRIB NEAR WINDOW WHERE CORDS FROM BLINDS OR DRAPES MAY STRANGLE A CHILD.

FALL HAZARD

- WHEN CHILD IS ABLE TO PULL UP TO STANDING POSITION, SET MATTRESS TO LOWEST POSITION AND REMOVE BUMPER PADS, LARGE TOYS AND OTHER OBJECTS THAT COULD SERVE AS STEPS FOR CLIMBING OUT.
- STOP USING CRIB WHEN CHILD BEGINS TO CLIMB OUT OR REACHES THE HEIGHT OF 35 INCH. (89CM).

CAUTION: ANY MATTRESS USED IN THIS CRIB SHALL BE AT LEAST 27-1/4 INCHES BY 51-5/8 INCHES (69 X 131 CM) WITH A THICKNESS NOT EXCEEDING 6 INCHES (15 CM) AND THE MINIMUM MATTRESS THICKNESS OF 4 IN.(10CM).

THIS PRODUCT CONFORMS TO APPLICABLE REGULATIONS PROMULGATED BY THE CONSUMER PRODUCT SAFETY COMMISSION.

ASSEMBLY INSTRUCTIONS (continued)

PARTS ENCLOSED IN CARTON

A 1 Back Rail Top

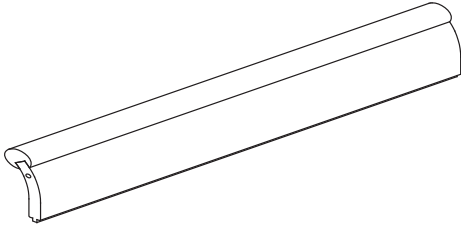

B 2 Crib Ends

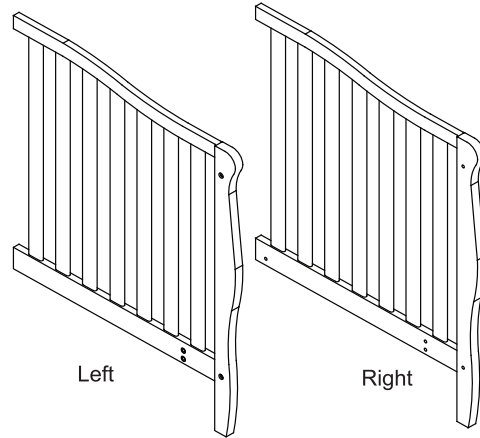

C 2 Left and Right Back Legs

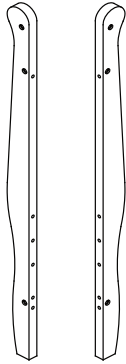

D 1 Back Rail Bottom

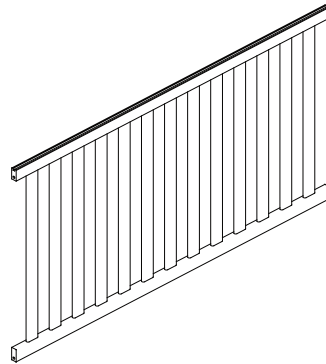

E 1 Front Rail

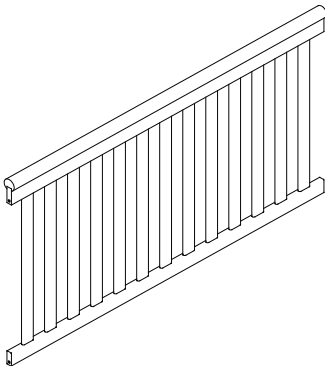

F 1 Bottom Stretcher Bar

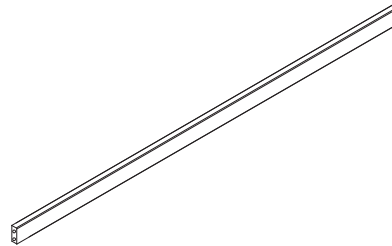

G 1 Metal Spring Support Platform

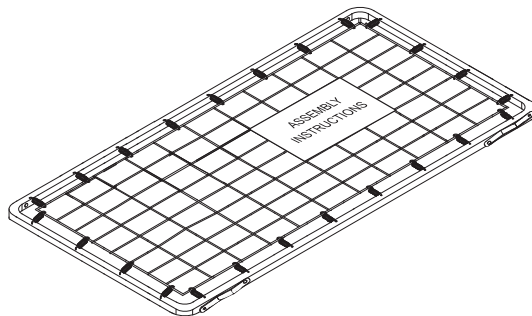

PRINTED IN CHINA

Crib Assembly

Step 1

Attach the Left & Right Back Legs (C) to the Back Rail Bottom (D) using 2-1/2" Allen head bolts (I) & barrel nuts (L).
See Figure 1.

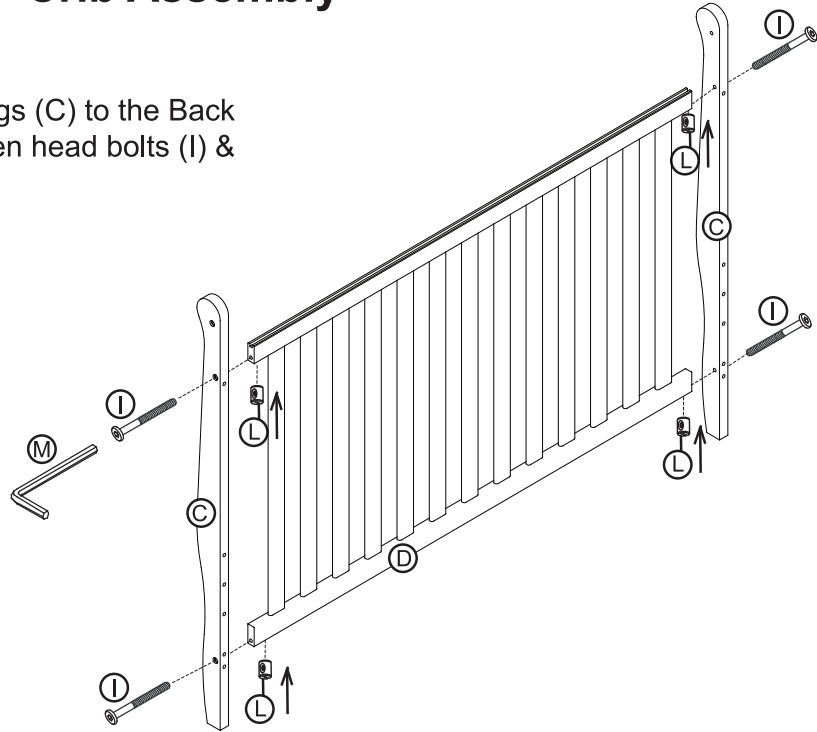

Model shown is example only.
Styles may vary.

Figure 1

Step 2

Insert the tenon of the Back Rail Top (A) into the slots of the Back Rail Bottom (D). Then, insert the 1-1/2" Allen head bolts (J) through the Legs (C) & into the threaded insets.
See Figures 2 & 2A.

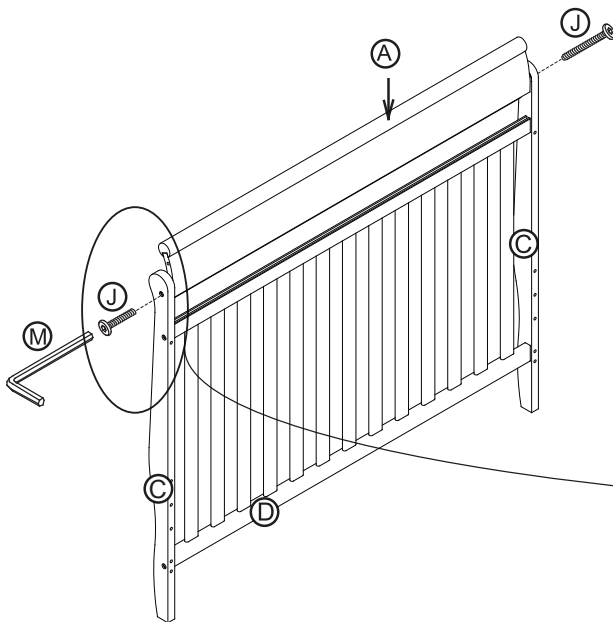

Figure 2

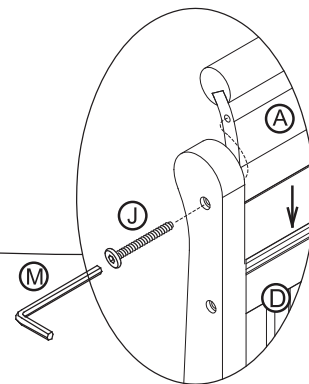

Figure 2A

Model shown is example only.
Styles may vary.

Step 3

Attach the assembled Back Rail (D) to the Crib Ends (B) using 3" Allen head bolts (H), barrel nuts (L) & 1-1/8" wood dowels (N). See Figure 3.

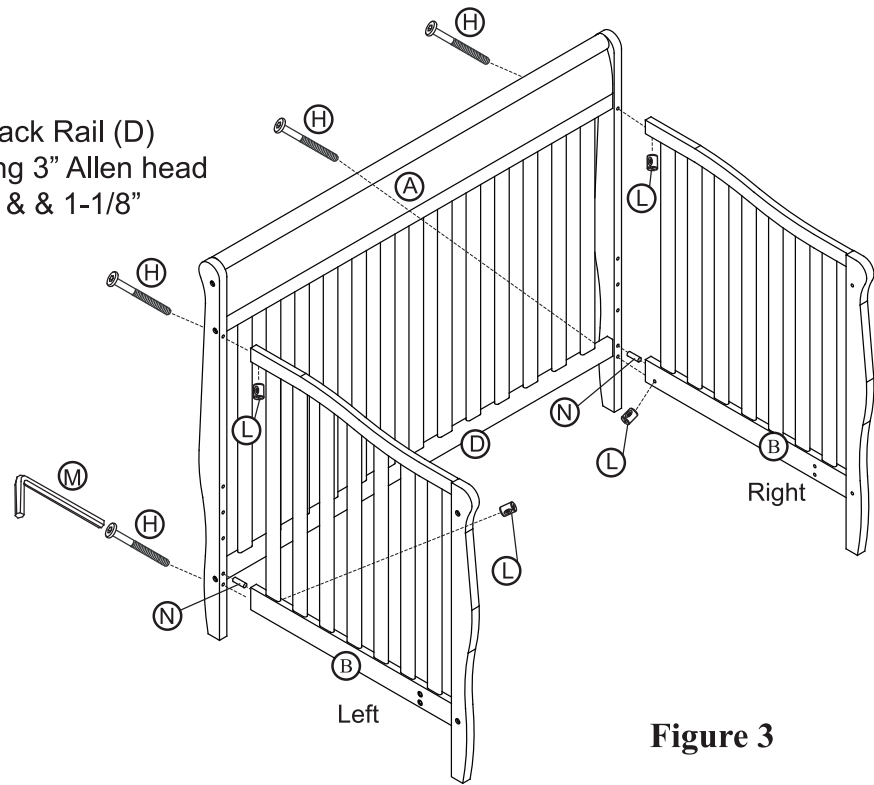

Figure 3

Model shown is example only.
Styles may vary.

Model shown is example only.
Styles may vary.

Step 4

Attach the Bottom Stretcher Bar (F) to the Crib Ends (B) using 2-1/2" Allen head bolts (I) & barrel nuts (L) as shown in Figures 4 & 4A.

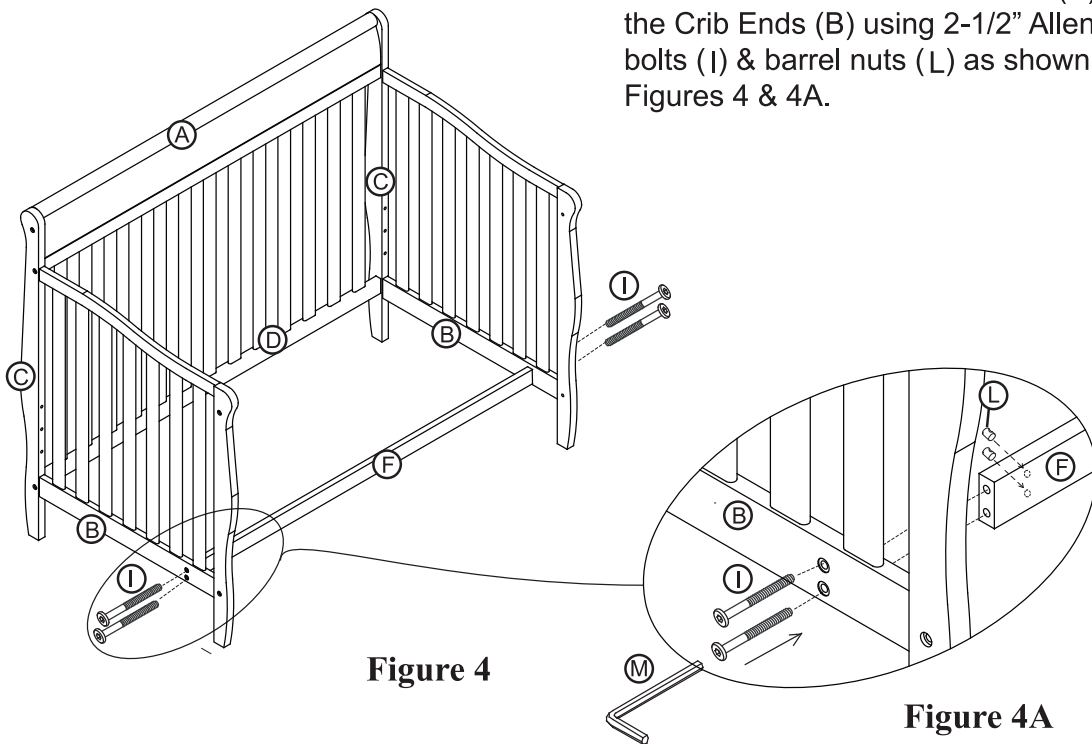

Figure 4

Figure 4A

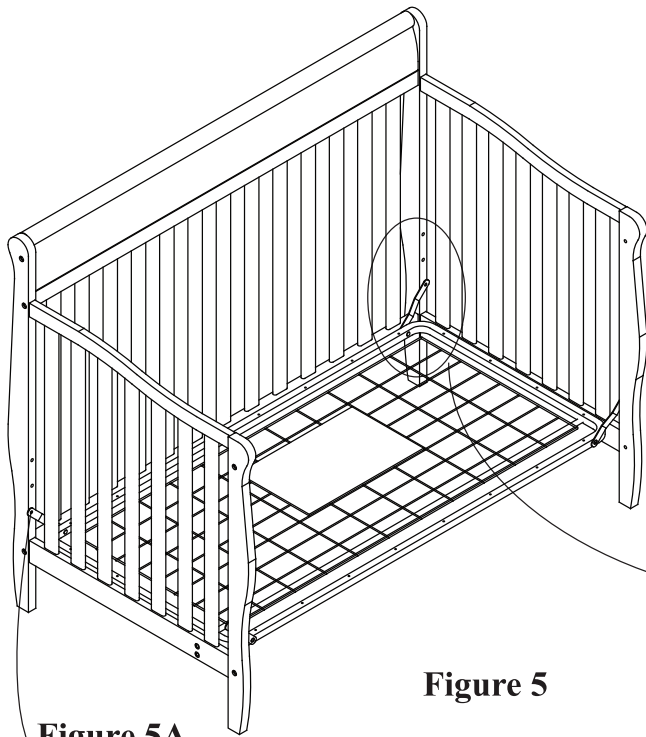

Figure 5A

Step 5

Locate the metal spring (G) with tabs. Be sure the smooth side of the metal spring is placed upward. Position the tabs of the metal spring to mount to selected position onto the legs (See Figure 5A). Insert the 3/4" Allen head bolts (K) through the tabs and into the threaded insets onto the legs. Tighten securely with Allen wrench (M) See Figure 5B.

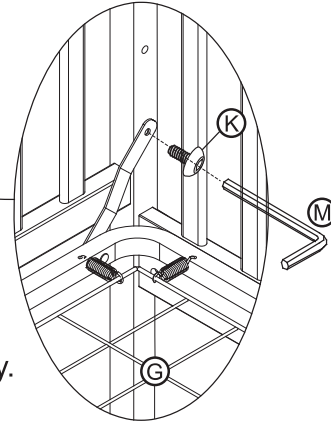
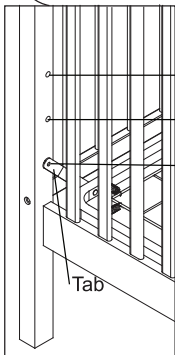

Figure 5B

Figure 5

Model shown is example only. Styles may vary.



Highest Position
Medium Position
Lowest Position
Tab

Spring shown here in lowest position.
Note: We recommend setting the spring in the highest position for newborn babies. Lower the mattress spring as the child grows and becomes more mobile.

Step 6

Attach the Front Rail (E) using 2-1/2" Allen head bolts (I) & barrel nuts (L). Tighten securely with Allen wrench (M). See Figure 6.

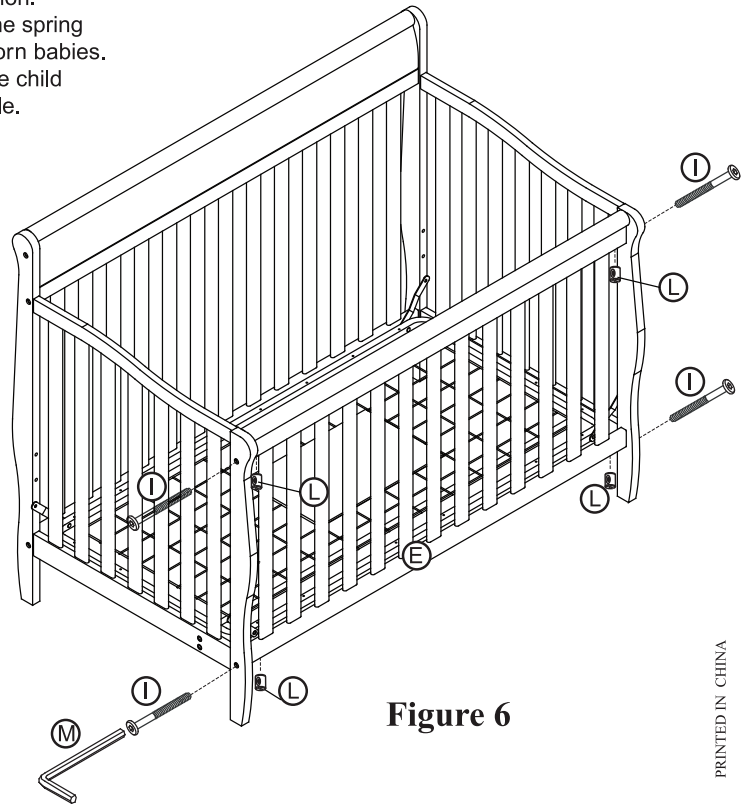

Figure 6

Model shown is example only. Styles may vary.

Converting Crib to a Toddler/Day bed

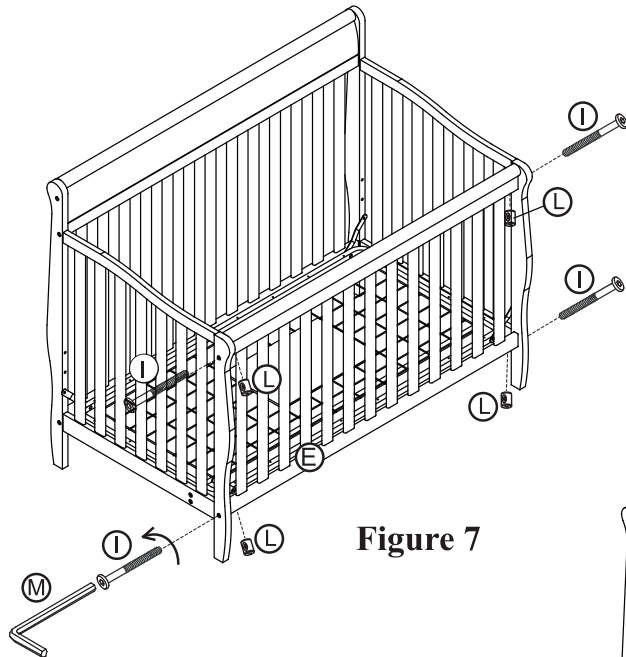

Figure 7

You have the option to convert crib to a Toddler / Day bed. Simply follow Step 6 in reverse order and remove the Front Rail (E). See Figures 7 and 7A.

IMPORTANT: Make sure to remove the fixed side close to the Bottom Stretcher Bar.

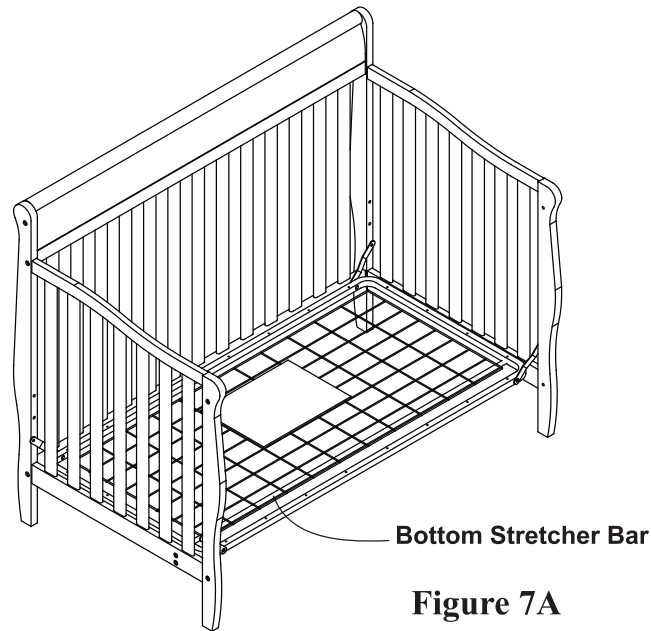

Figure 7A

Model shown is example only.
Styles may vary.

WARNING!

FOR TODDLER BED USE

- Failure to follow these warnings and assembly instructions could result in serious injury or death from entrapment or strangulation.
- DO NOT place bed near windows where cords from blinds or drapes may strangle a child.
- DO NOT place items with a string, cord, or ribbon around a child's neck, such as a hood, strings or pacifier cords.
- DO NOT suspend strings over a toddler bed for any reason.
- The mattress intended for use on the bed shall be a full-size crib mattress having the dimensions of 51 5/8 in. (1310mm) in length and 27 1/4 in. (690mm) in width and thickness of 4 in. (100mm) or a greater thickness as specified by the manufacturer.
- The minimum age of the intended user shall not be less than 15 months and the maximum weight shall not be greater than 50 Lbs. (22.7Kg).

Converting Crib to a Full Size Bed

You have the option to convert the crib to a full size bed. Simply follow Steps 3 through 6 in reverse order to disassemble the crib to get the headboard as shown in Figure 8. Attach it to a full size metal bed frame (NOT INCLUDED) to convert to a full size bed.

Model shown is example only.
Styles may vary.

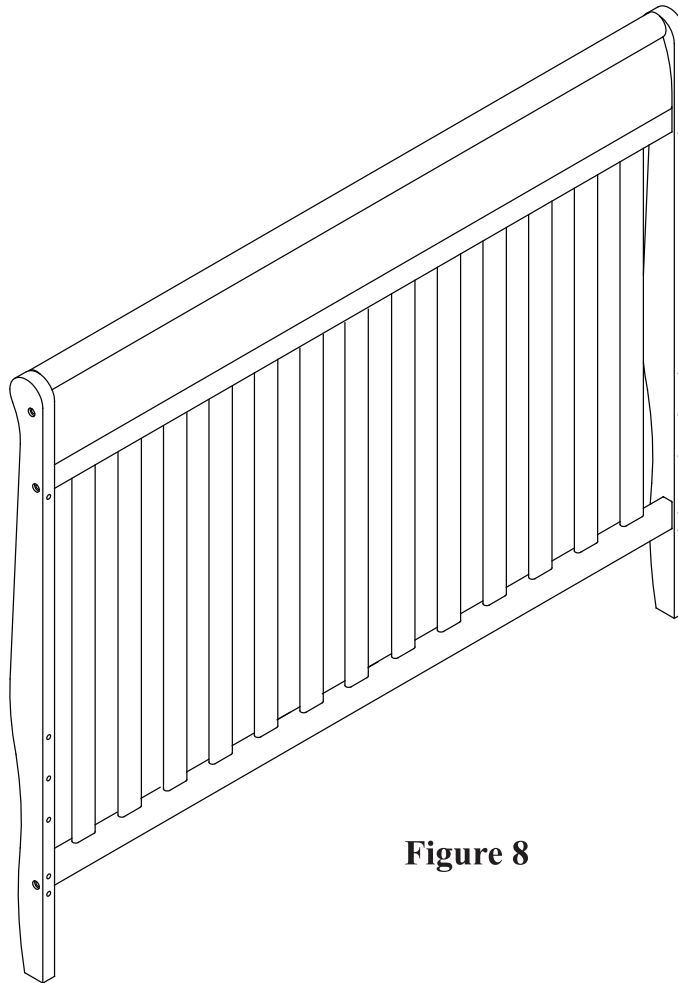

Figure 8

STORAGE AND CARE/DÉMONTAGE DU LIT DE BEBE/ALMACENAMIENTO Y CUIDADO

DO NOT remove any part that is attached with wood screws, The stationary side rail, mattress base can all be disassembled for storage. Simply review the assembly instructions for each and reverse the order to disassemble. Wipe all parts with a dampened clean cloth. DO NOT use abrasives. To convert to a double bed please follow the instructions in the double bed kit. (MUST BE PURCHASED SEPARATELY)

Les panneaux avant, arrière, droit, gauche et le support de matelas peuvent être détaché et entreposer. Simplement suivre les instructions de montage au revers. Nettoyer le lit a l'aide d'un chiffon humide, ne jamais utiliser un détergeant ou produit abrasif.

Los paneles delantero, trasero (C/D), los paneles izquierdo y derecho (A/B) y la base del colchón pueden ser removidos para su almacenaje.. Para desmantelar, seguir las instrucciones de ensamblaje al revés. Para limpiar, use un paño húmedo. Nunca utilizar un producto abrasivo.

LIMITED ONE YEAR WARRANTY / GARANTIE LIMITEE D'UN AN/UN AÑO DE GARANTÍA LIMITADA

Your product is warranted against defects in workmanship or material for ONE YEAR from the date of the original purchase. This warranty shall be limited to repairing or replacing any part of the product which, in the opinion of the company, shall be proved defective in materials or workmanship under normal use and service during the one year warranty period. During the one year warranty period, repair or replacement of parts shall be made at no charge. Date of purchase of the product must be established by production of your sales slip or other satisfactory evidence.

Votre produit a une garantie contre tout vice de matériau ou de fabrication pendant UN AN a compter de la date d'achat. Cette garantie est limitée a la réparation ou du remplacement de toute pièce qui, a l'avis de la société, s'avère défectueuse dans les conditions normales d'utilisation, en raison d'un vice de matériau ou de fabrication pendant la période de garantie d'un an. La société réparera ou remplacera gratuitement les pièces défectueuses. La date d'achat du produit doit être établie en présentant votre reçu de caisse ou autre preuve satisfaisante.

Este producto está garantizado contra defecto en la mano de obra o material usado por UN AÑO desde la fecha original de compra. Esta garantía se limita a la reparación o el reemplazo de cualquier parte del producto los cuales, al juicio de la compañía, resulten defectuosos en los materiales o mano de obra bajo uso normal durante el periodo del año de garantía. Durante el año de garantía, las reparaciones y las piezas de reemplazo no tendrán costo alguno. La fecha de compra del producto será establecida por su recibo de compra o cualquier otra prueba o evidencia satisfactoria.

HOW TO GET PROMPT, EFFICIENT SERVICE / POUR UN SERVICE RAPIDE ET EFFICACE / PARA UN SERVICIO EFICIENTE

Contact our customer service department. The telephone number and hours of operation are listed below. Please do not return the product to the store where it was originally purchased as they do not stock replacement parts. When calling our customer service department, make sure to mention the **model number and date of manufacture**. Both can be found on the end panel. It is company policy to respond to each request as quickly as possible.

Veillez vous communiquer avec notre service aux clients. Le numéro de téléphone et les heures d'ouverture son indique ci-dessous. Ne pas retourner ce produit au marchand puisse qu'il n'entrepose aucune pièces de rechange. Veuillez mentionnez le numéro de modèle, la date de fabrication et le pays d'origine qui se trouve sur la tête de lit. Le fabricant a pour politique de répondre le plus rapidement à chaque demande.

Comuníquese con nuestro servicio al cliente. El número de teléfono y horario de atención está indicado a continuación. Por favor no devolver el artículo a la tienda donde fue comparado originalmente, ellos no tienen piezas de reemplazo en stock. Cuando llame a nuestro servicio al cliente por favor proporcionar el número de modelo, la fecha y el país de fabricación. La información se encuentra en un adhesivo en la parte interior de la cuna. La misma información la encontrara en la caja en la que recibió el producto.

Mode# /Modeøle No/Numéro de modèlo _____

Pack Date/Date d'emballage/Fecha de embalaje: _____

Date of Purchase/Date d'achat/Fecha de compra: _____ (you should also keep your receipt)

(Por favor guardar sus recibos)

(Veillez garder votre reçu)

Customer Service Direct Telephone line: **1-877-274-0277** Fax **(604) 274-9727**

Hours of operation: 7:00 AM to 3:00 PM, Pacific Standard Time

e-mail: parts@storkcraft.com

Service a la clientèle - Téléphone: **1-877-274-0277** Telecopieur **(604) 274-9727**

Heures d'ouverture: 7h a 15 h 00 (Heure normale du Pacifique)

e-Mail: parts@storkcraft.com

Servicio de línea telefónica directa al cliente: **1-877-274-0277** FAX **(604) 274-9727**

Horario de atención: 7:00 am a 3:00 pm, hora del pacifico

e-Mail: parts@storkcraft.com

DISTRIBUTED BY/ DISTRIBUE PAR:

Stork Craft Mfg. (USA), Inc.,
3993 Howard Hughes Parkway, Unit#250 Las
Vegas, NV, USA.89169
Tel: 1 877 274 0277

Twitter@Storkcraft