

# INSTRUCTIONS: 2" New Construction Housing

## Model: HR-2LED-H09D-ICA, HR-2LED-H09-HICA

### Important:

Read all instructions before installing.

For installation by a qualified electrician.

System is intended for installation in accordance with National Electric Code, and local regulations. Consult with local inspector to assure compliance.

To reduce the risk of fire, electrical shock and injuries to persons, turn off power at main switch before installing or modifying the system.

Retain instructions for future maintenance reference.

### Overview:

It is a new construction housing, IC type. Housing requires a trim from the HR-2LED-\* series. May be used with an electronic low voltage dimmer.

### Mounting:

1. Install mounting frame using two hanger bars, (24 1/2" max). Bars are notched on the ends to fit over "T" bars in suspended ceilings. Hanger bars include a captive mounting "screw-nail" for ease of installation (as Fig.1). Align the bottom of the hanger bar with the bottom of the wood joist. Secure the "screw-nail" on each end by screwdriver (as Fig.A), or by hammer (as Fig.B).
2. Slide fixture along bar hangers into desired location. Use locking screws to secure (as Fig.C).
3. Junction box is suitable for branch wiring and has trade size knockouts and integral non-metallic sheathed cable connectors.
4. Remove spring latched junction box door and connect fixture wires to building wires: insert each supply wire into appropriate junction box connector. Connect brown/black fixture wire to hot wire, blue/white fixture wire to neutral wire and green fixture wire to ground (as Fig.2).
5. Place all wiring and connectors back in wiring box and replace junction box door.
6. When installing in drywall, cut a hole 3 7/8" in the drywall. Note: 3/4" inch maximum ceiling thickness.
7. Push the trim assembly up until the trim ring is flush to the ceiling (as Fig.3, Fig.4 and Fig.5).

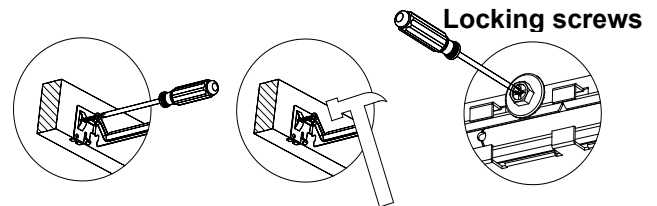
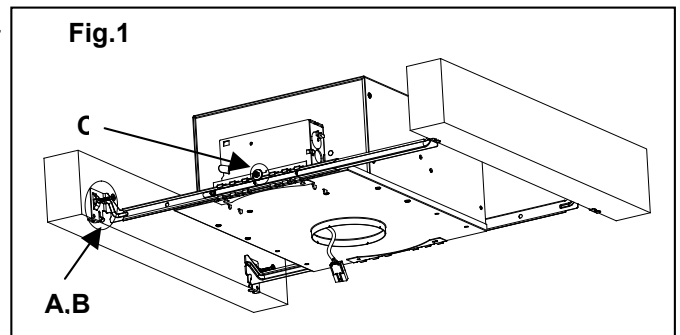

Fig.A

Fig.B

Fig.C

