

# T-K4-IN

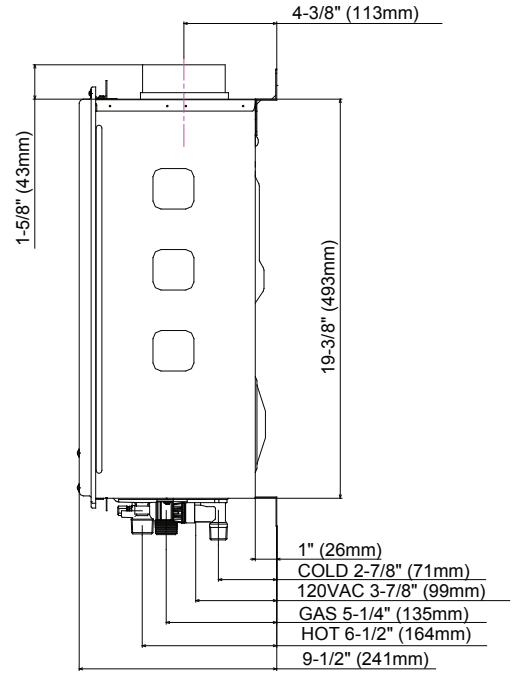
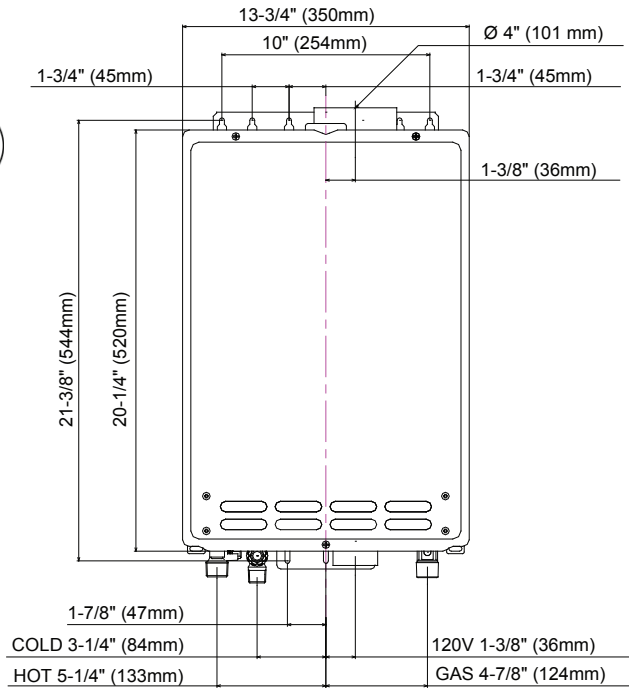

Dimension	H20.3" x W13.8" x D8.5" Weight: 38 lbs
Hot/Cold/Gas Connection	3/4" NPT
Clearances	Top: 12" Bottom: 12" Front: 24" Back: 1" Sides: 2"

## Features

- Fully modulating, gas-fired, tankless water heater
- Indoor installation only (Direct-vent convertible)
- Safety Features:
  - Air-Fuel Ratio (AFR) sensor
  - Exhaust & Water Temperature Safety Control
  - Overheat Cutoff Fuse
- Internal Freeze-Protection System
- Manual reset high limit switch
- Power Cord included
- Temperature Remote Controller included (TK-RE02)

## Venting & Combustion

- Horizontal or Vertical Installation
- Power Vent
- Electric Ignition
- Flue 4" O.D.
  - Category III Stainless Steel
- Intake 3" O.D.
  - ABS, PVC, Galvanized Steel, Corrugated Stainless Steel or Category III/IV Stainless Steel
- 50' Max Length, 5 elbows max (90°elbow = 5' equivalent length)

## Accessories

- TK-PC01 Pipe Cover
- TK-BF01 Backflow preventor
- TK-KPCT43 3X4 DV Concentric Termination
- TK-TV10 Direct Vent Conversion Kit
- TK-KPWL4 and TK-KPWH4 Wall Thimble Louver/Hood Termination

# T-K4-IN



**Flow Rate vs. Temperature Rise**

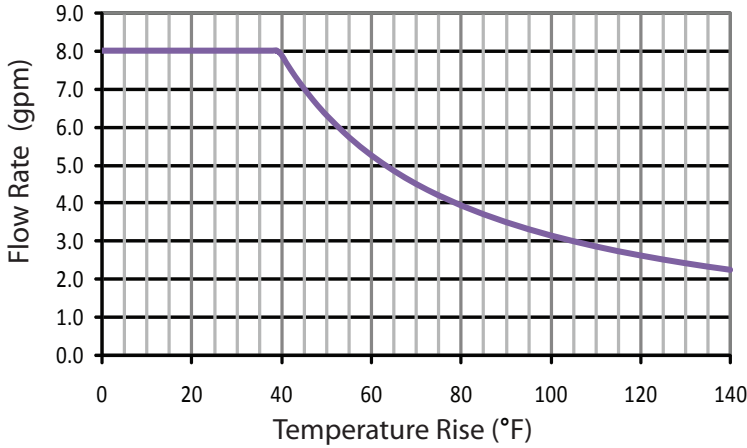

**Pressure Loss**

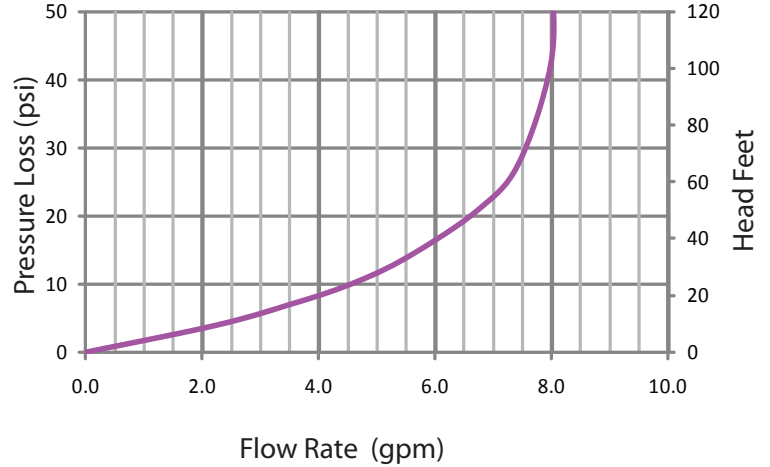

<b>Installation Type</b>	Indoor installation only (Direct-vent convertible)	
<b>Electric Consumption</b>	120 VAC ; Standby: 0.05 A, Operation: 0.73 A, Freeze-Protection: 0.93 A	
<b>Fuel</b>	NG	LP
<b>Gas Consumption Input</b>	Min 11,000 BTU/h Max 190,000 BTU/h	Min 11,000 BTU/h Max 190,000 BTU/h
<b>Energy Factor</b>	0.82	0.82
<b>Inlet Gas Pressure</b>	Min 5.0" W.C. Max 10.5" W.C.	Min 8.0" W.C. Max 14.0" W.C.
<b>Flow Rate</b>	Max 8.0 GPM	
<b>Water Pressure</b>	15-150 psi	Pressure Only Relief Valve Required (Min 200,000 BTUs. 150 psi) 40 psi or above recommended for maximum flow
<b>Temperature Settings</b>	Without Remote (Dipswitch Setting)	113°F, 122°F (Default), 131°F, and 140°F
	With TK-RE02 Temperature Remote Controller : 99°F to 167°F, 122°F Default Factory Setting	99°F, 100°F, 102°F, 104°F, 106°F, 108°F, 109°F, 111°F, 113°F, 115°F, 117°F, 122°F (Default), 131°F, 140°F, 158°F, and 167°F