

T-D2-IN

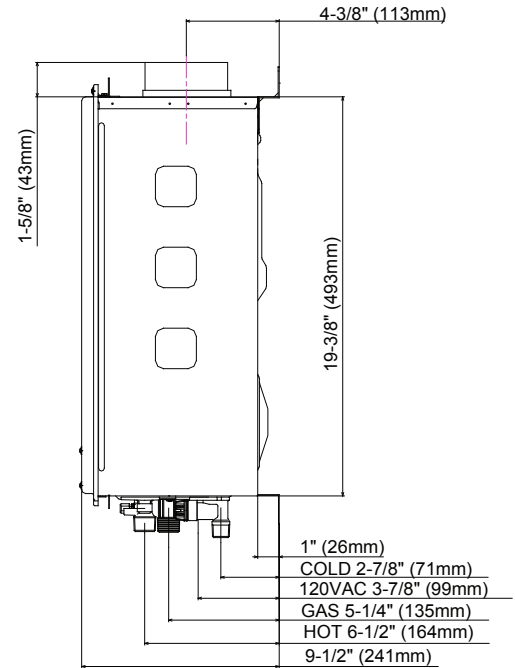
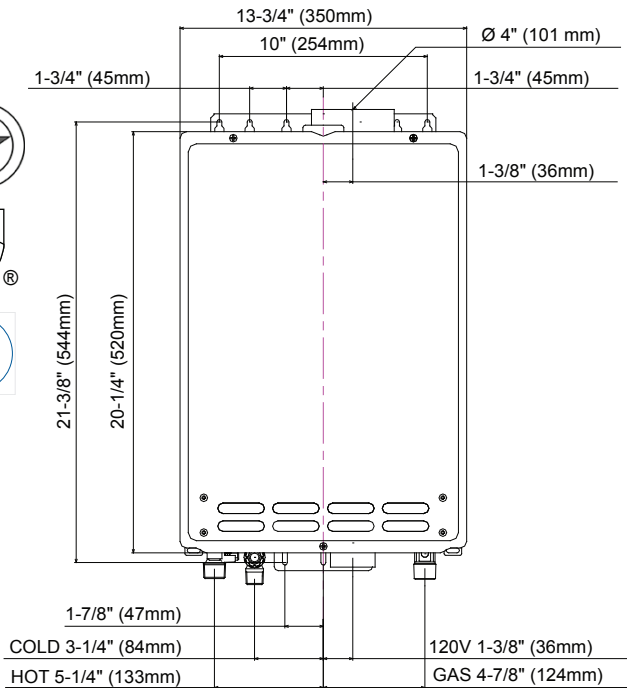

Dimension	H20.3" x W13.8" x D8.5" Weight: 39 lbs
Hot/Cold/Gas Connection	3/4" NPT
Clearances	Top: 12" Bottom: 12" Front: 24" Back: 1" Sides: 2"

Features

- Fully modulating, gas fired, tankless water heater
- Indoor and Direc Vent installation only
- Safety Features:
 - Air-Fuel Ratio (AFR) sensor
 - Exhaust & Water Temperature Safety Control
 - Overheat Cutoff Fuse
- Internal Freeze-Protection System
- Manual reset high limit switch
- Easy-link up to 4 units without multi unit controller
- HRS 35 Copper on Heat Exchanger
- Power Cord included
- Temperature Remote Controller included (TM-RE30)

Venting & Combustion

- Horizontal or Vertical Installation
- Power Vent
- Electric Ignition
- Flue 4" O.D.
 - Category III / IV Stainless Steel
- Intake 3" O.D.
 - ABS, PVC, Galvanized Steel, Corrugated Stainless Steel or Category III/IV Stainless Steel
- 4" ; 50' Max Length, 5 elbows max (90°elbow = 5' equivalent length)

Accessories

- TK-BF01 Backflow preventor
- TK-KPCT43 3X4 DV Concentric Termination
- TK-TV10 Direct Vent Conversion Kit
- TK-KPWL4 and TK-KPWH4 Wall Thimble Louver/Hood Termination
- TK-PC01 Pipe Cover

T-D2-IN



Flow Rate vs. Temperature Rise

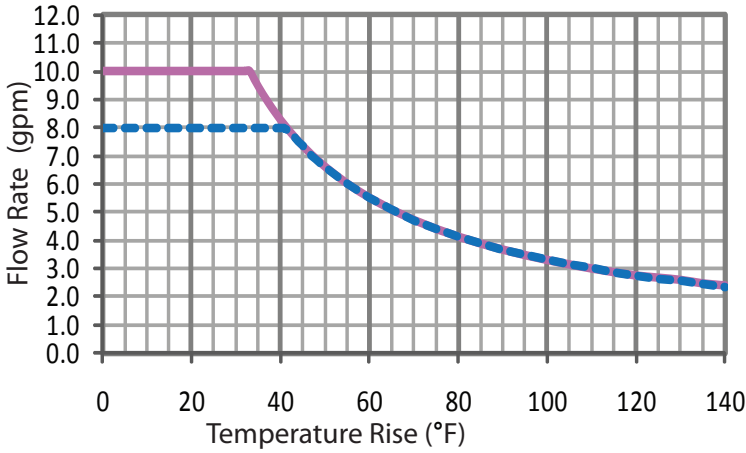

Pressure Loss

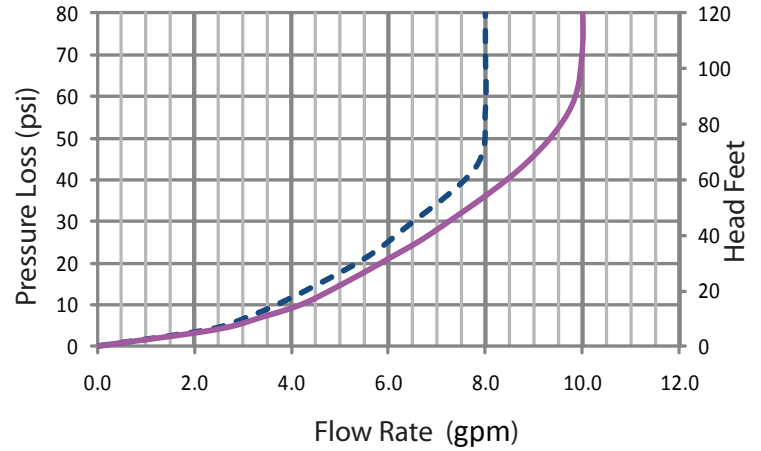

— Set Temperature : 122 °F & lower
- - - Set Temperature: 131 °F & higher

Installation Type	Indoor and Direct Vent Only	
Electric Consumption	120 VAC ; Standby: 0.05 A, Operation: 0.75 A, Freeze-Protection: 0.93 A	
Fuel	NG	LP
Gas Consumption Input	Min 11,000 BTU/h Max 199,000 BTU/h	Min 11,000 BTU/h Max 199,000 BTU/h
Energy Factor	0.83	0.82
Inlet Gas Pressure	Min 5.0" W.C. Max 10.5" W.C.	Min 8.0" W.C. Max 14.0" W.C.
Flow Rate	Max 10.0 GPM	
Water Pressure	15-150 psi	Pressure Only Relief Valve Required (Min 200,000 BTUs. 150 psi) 40 psi or above recommended for maximum flow
Temperature Settings	Without Remote (Dipswitch Setting)	104°F, 113°F, 122°F (Default), 131°F, 140°F, 158°F, 176°F, and 185°F
	With TM-RE30 Temperature Remote Controller : 99°F to 185°F, 122°F Default Factory Setting	99°F, 100°F, 102°F, 104°F, 106°F, 108°F, 109°F, 110°F, 111°F, 113°F, 115°F, 117°F, 122°F (Default), 131°F, 140°F, 158°F, 167°F, 176°F, and 185°F