

Port Alone

700FJFCP_, CK001P-FJ- 1.0



ENCOMPASS LIGHTING GROUP
SINGLE PORTS

GENERAL PRODUCT INFORMATION:



This product is suitable for dry locations only.

Prior to the steps below, make sure that the remote transformer(s) and all power connections are installed according to local electrical codes.



Run Power from the Remote Transformer(s) to the Ports

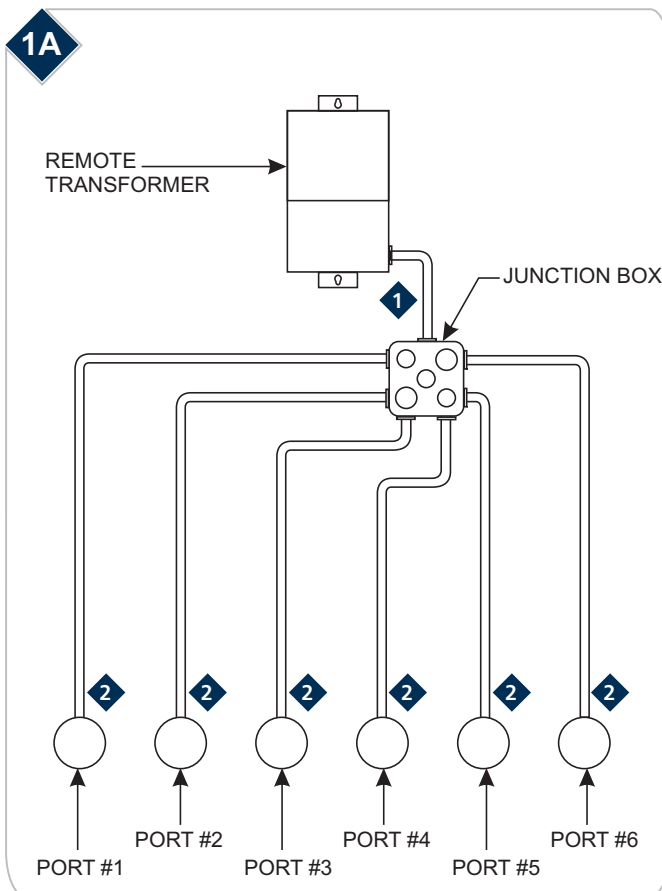

- 1 Run the power from the remote transformer to a junction box, refer to the voltage drop chart provided in the transformer documentation. For 600 watt remote transformer with dual circuit breakers, a junction box for each circuit will be required.
- 2 Branch the power from the junction box to each port. For recommended wire size, refer to the chart below. **Note that each power branch should be no longer than 20'.**

Transformer Voltage	Transformer Wattage	Wire Size For 20W Port	Wire Size For 50W Port	Wire Size For 75W Port
12V	150W	#14 GA	#12 GA	#10 GA
12V	300W	#14 GA	#12 GA	#10 GA
24V	300W	#18 GA	#18 GA	#16 GA

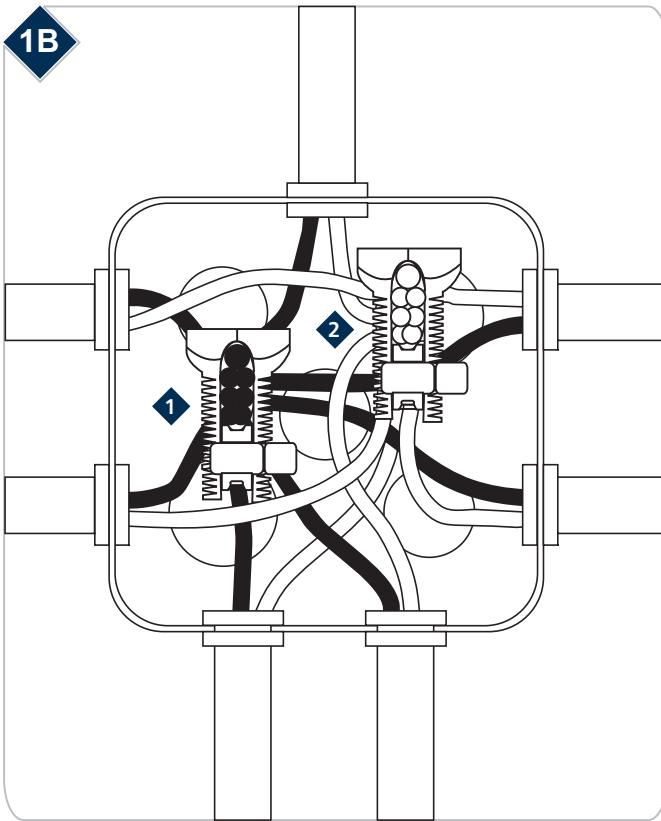

- 1 Using a split bolt connector, connect the low voltage hot wire coming from the remote transformer to each hot wire going to the ports.
- 2 Connect the low voltage common wire coming from the remote transformer to each common wire going to the ports.
- 2 Make sure that the split bolt connectors are properly insulated.

Install the Single Port Alone

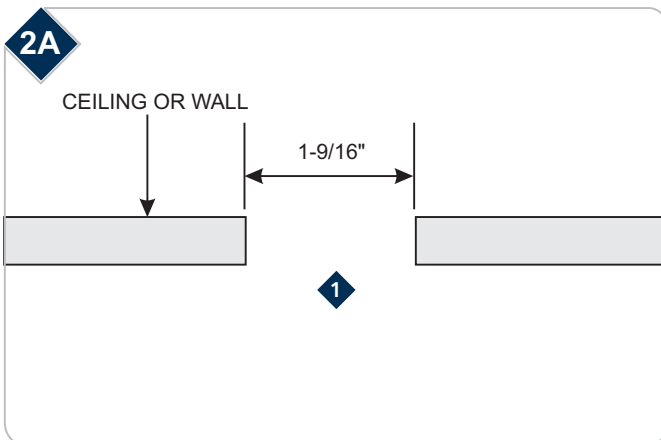

- 1 Use a 1-9/16" hole saw to cut out the ceiling or wall where the ports are going to be installed.

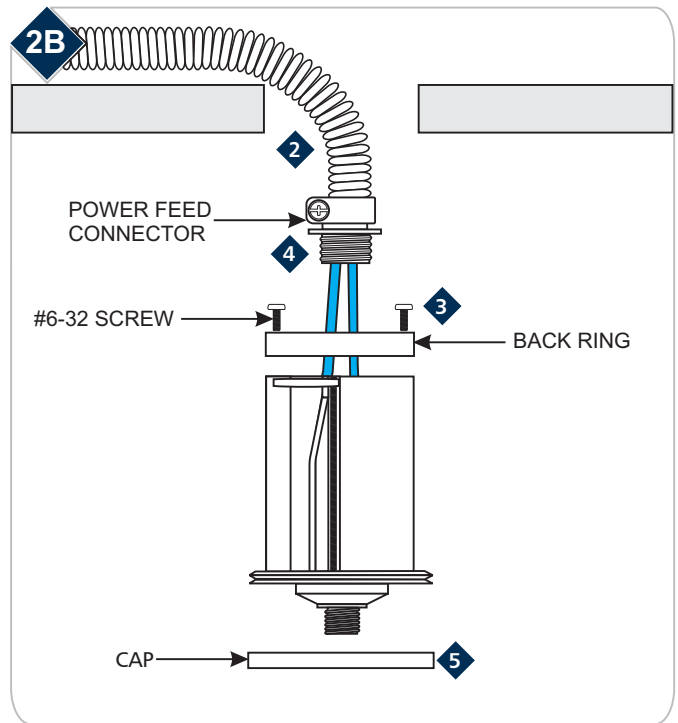

- 2 Bring the power out of the opening.
- 3 Unscrew the #6-32 screws to remove the back ring.
- 4 Screw the back ring (from the face with two holes) to the power feed connector.
- 5 Unscrew the cap from the port.

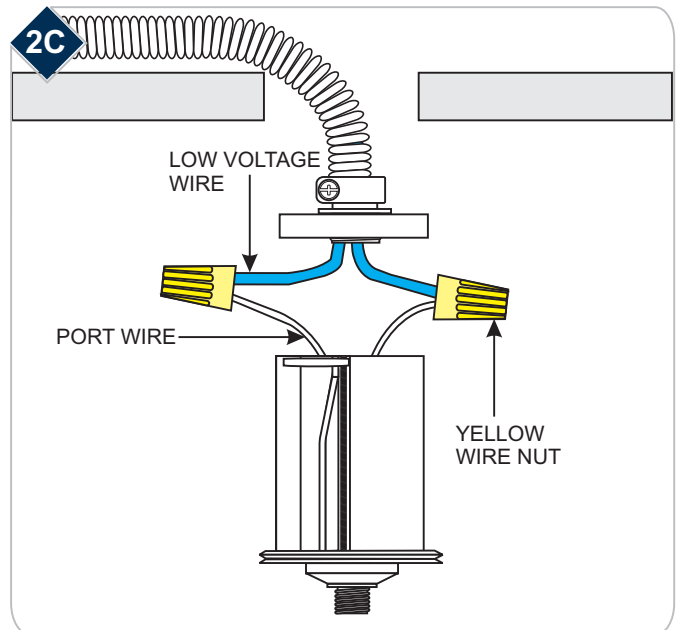

- 6 Cut the port wires so that 1-1/2" of it is exposed.
- 7 Strip the port wires and connect them to the low voltage wires with the provided yellow wire nuts.

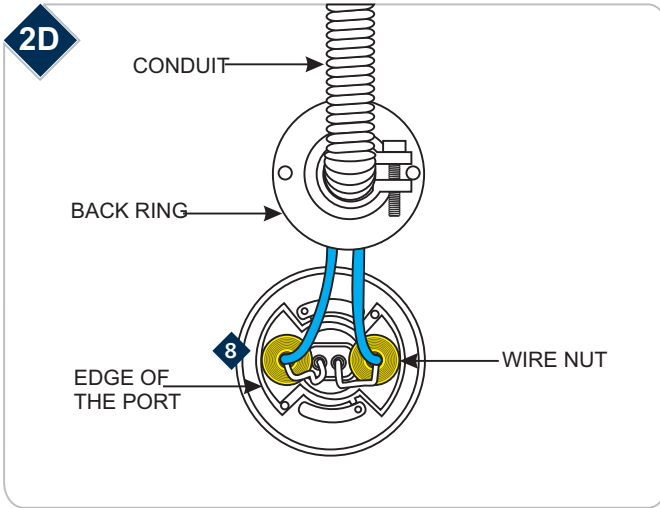

- 8 Place the wire nut connections and the port wires properly inside the port. Make sure that the port and low voltage wires are cleared from the edge of the port.

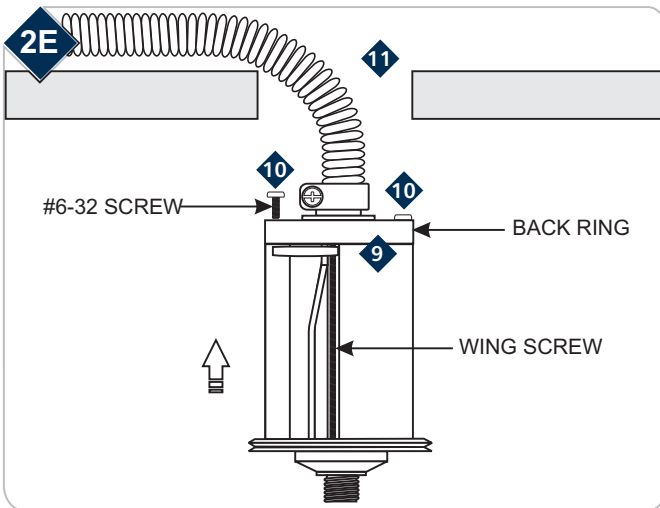

- 9 Replace the back ring onto the port so that end of the wing screws are properly place into the two blind holes.
- 10 Replace and tighten the #6-32 set screws to secure the back ring onto the port.
- 11 Push the port completely into the hole.

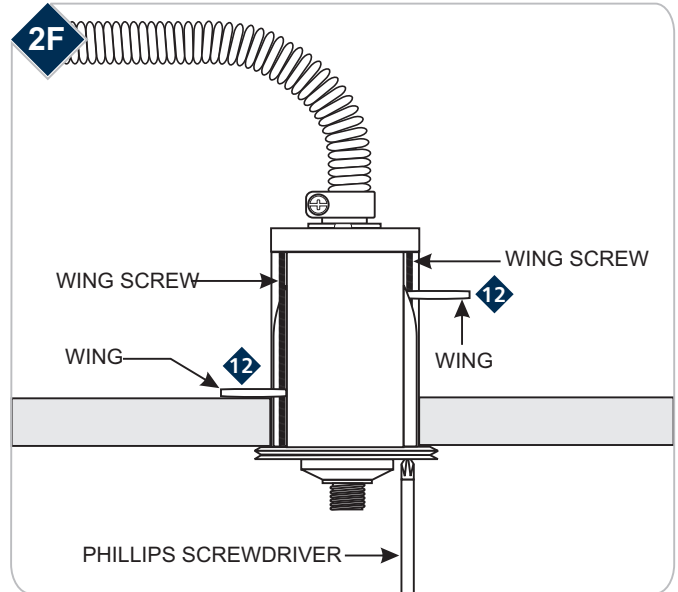

- 12 Tighten the two phillips screws with a Phillips screwdriver (an electrical screwdriver will speed up the process) until the wings secure the port into the hole.

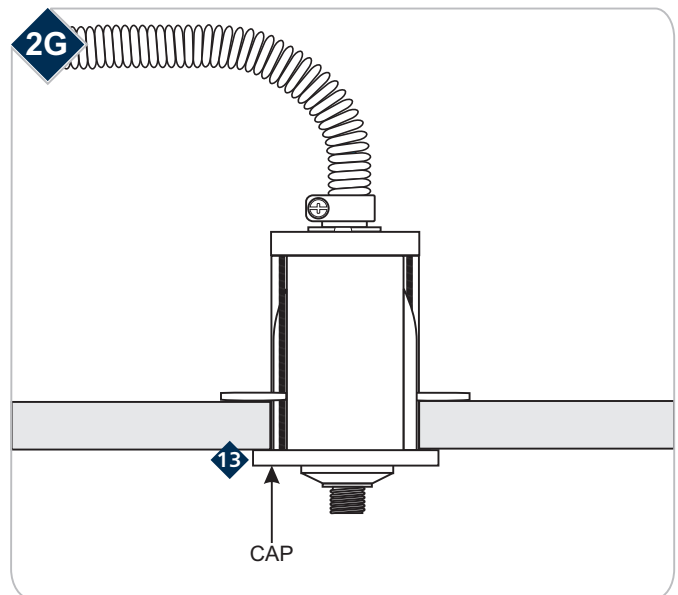

- 13 Replace and tighten the cap.
- 14 Repeat steps 1 through 13 for each port.

Connect the Fixture to the Port

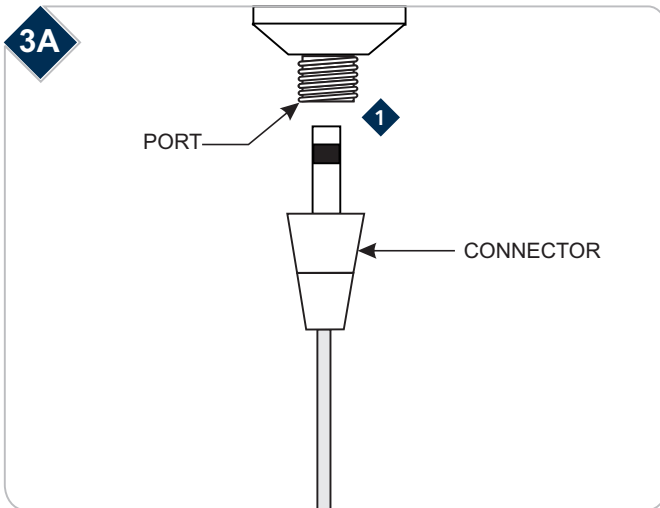

- 1 Screw the fixture connector completely into the port.

SAVE THESE INSTRUCTIONS!



ENCOMPASS LIGHTING GROUP

7400 Linder Ave, Skokie, IL 60077

847.410.4400

www.encompasslighting.com

© 2008 Encompass Lighting Group. All rights reserved. The "Encompass Lighting Group" graphic is a registered trademark of Encompass Lighting Group. Encompass Lighting Group reserves the right to change specifications for product improvements without notification.

A Generation Brands Company