

American Standard

Installation Instructions

**1480.500 SERIES
1480SS.500 SERIES
T480.500 SERIES**

Seva™

PRESSURE BALANCED BATH AND SHOWER FITTINGS

Thank you for selecting American-Standard...the benchmark of fine quality for over 100 years.

To ensure that your installation proceeds smoothly—please read these instructions carefully before you begin.

Certified to comply with ANSI A112.18.1
U.S. Patent No. D400,652

M968395A



ROUGHING-IN DIMENSIONS

■ To assure proper positioning in relation to wall, note roughing-in dimensions.

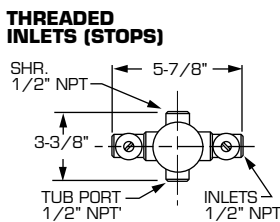
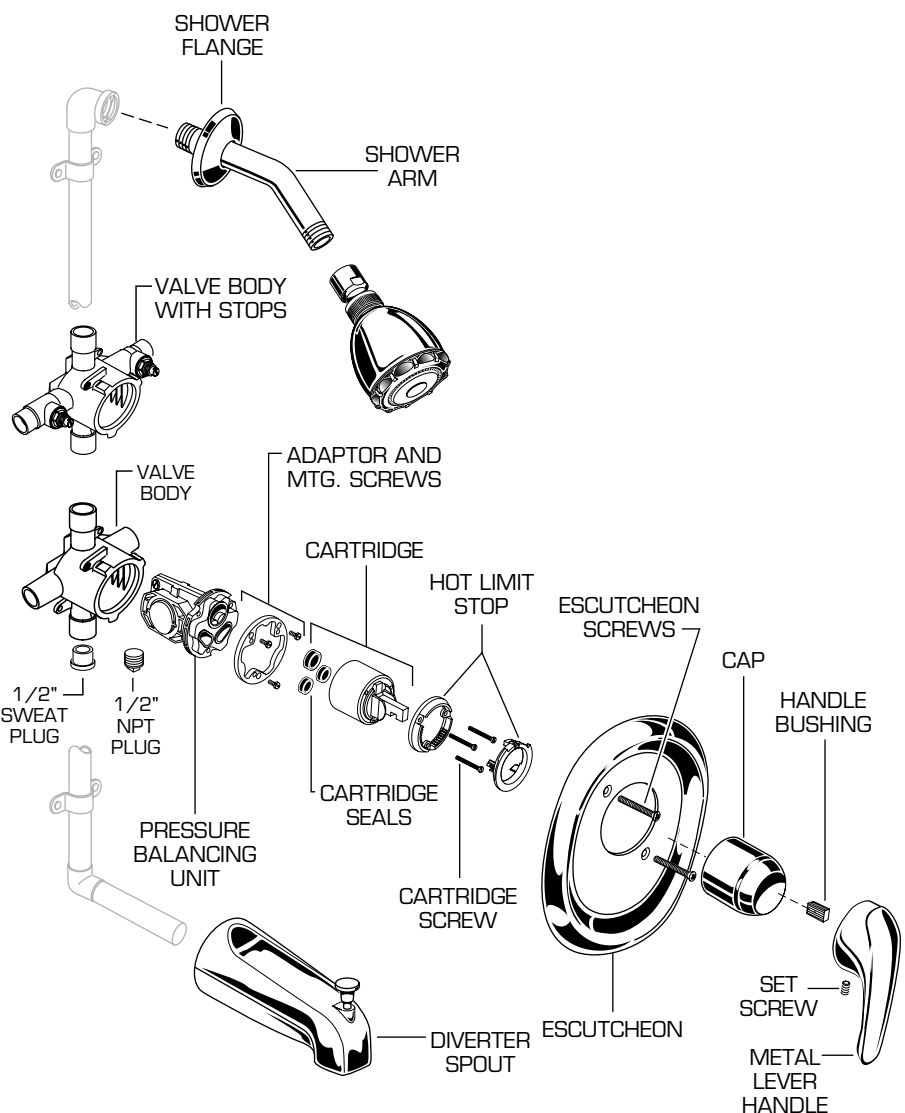
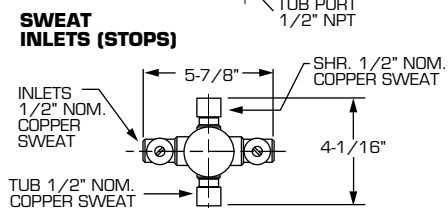
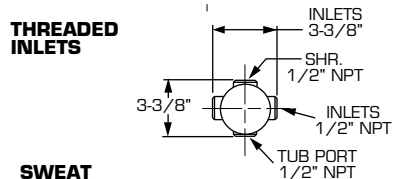
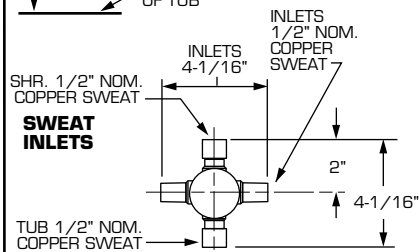
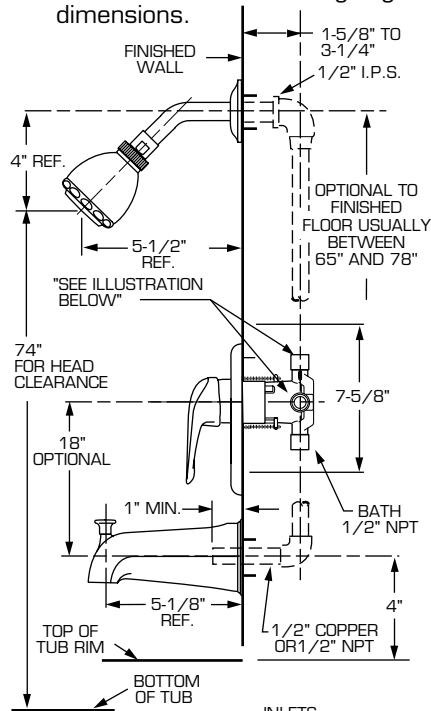

HOTLINE FOR HELP
For toll-free information and answers to your questions, call:
1 (800) 223-0068
Weekdays 8:00 a.m. to 7:00 p.m. Eastern Time
IN CANADA 1-800-387-0369 (TORONTO 1-905-306-1093)

Product names listed herein are trademarks of American Standard Inc.
©American Standard Inc. 2000

1

CAUTION

Turn off water at MAIN supply. To prevent damage temporarily remove STOPS when water supply lines are soldered to the manifold.

NOTE

When soldering, remove PLASTER GUARD, CARTRIDGES and CHECK STOPS (IF PRESENT). When finished soldering, flush valve body, replace cartridges, check stops (if present) and plaster guard to continue installation. Use thread sealant or Teflon tape on threaded connections

ROUGHING-IN

- See Roughing-in diagram on reverse side.
 - Connect RISER PIPE to MANIFOLD top outlet marked "SHR".
 - Connect TUB FILLER PIPE at bottom outlet marked "TUB".
 - Supply connections are:
 - 1/2" copper sweat for sweat inlets.
 - 1/2" female NPT for threaded inlets.
 - For proper positioning the finished wall must be within side wall of PLASTER GUARD.
 - If the valve is installed on a fiberglass or other thin wall application, the PLASTER GUARD can be used as a support:
 - Cut a 3" dia. hole in the shower stall.
 - If stops are used drill two additional 1" holes to allow access to the stops.
 - Remove PLASTER GUARD, rotate 180° so that indicated screw holes fit manifold.
 - Push CAP on valve, place ESCUTCHEON and attach with screws.
 - Connect hot and cold water supplies.
 - For support, use pipe BRACES secured to wooden braces.
- With valve turned off, turn on water supplies and check for leaks.

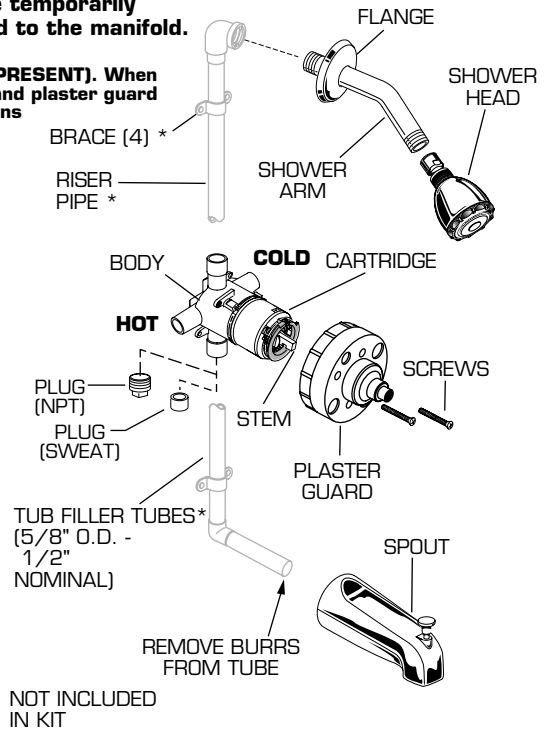

2

INSTALL TRIM

- When finished, tiling the wall, remove PLASTER GUARD.
- Push on CAP.
- Mount ESCUTCHEON with SCREWS.
- Install HANDLE by pushing it onto CARTRIDGE STEM and tightening SET SCREW from below.
- Install SHOWER ARM with FLANGE and SHOWER HEAD. Install SPOUT.
- Check proper operation of HANDLE and DIVERTER SPOUT.

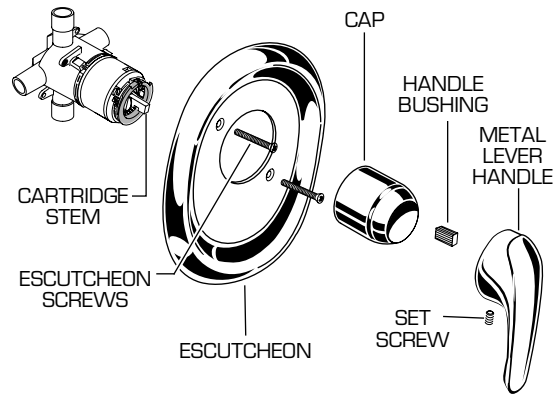

3

HOT LIMIT STOP

By restricting handle rotation and limiting the amount of hot water allowed to mix with the cold, the HOT LIMIT SAFETY STOP reduces risk of accidental scalding. To set the maximum hot water temperature of your SEVA faucets, all you need to do adjust the setting on the HOT LIMIT SAFETY STOP.

- Remove HANDLE, CAP and HOT LIMIT STOP. Follow "A" or "B" to adjust maximum discharge temperature.

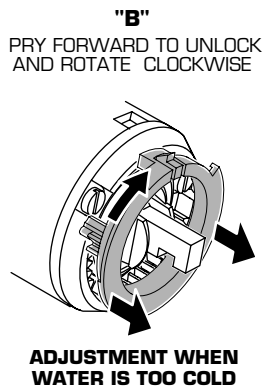
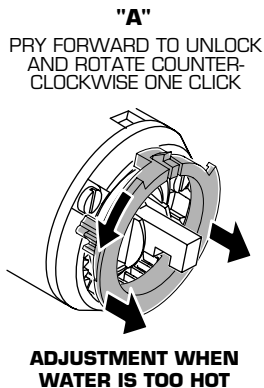

4

SERVICE

- If faucet drips, operate handle several times from "off" to "on". Do not apply excessive force.
- Clogged CARTRIDGE inlets may cause reduced flow in "full on" hot or cold. To clean inlets, first turn off water supply, then:
 - Remove HANDLE, CAP, HOT LIMIT STOP and CARTRIDGE. Clean inlets and MANIFOLD.
 - Reassemble CARTRIDGE, alternately tightening screws. Replace HOT LIMIT STOP, CAP and HANDLE. Check flow.

