



IF PARTS ARE MISSING AND OR DEFECTIVE, IF INSTRUCTIONS ARE NOT CLEAR  
OR IF YOU ARE EXPERIENCING PROBLEMS ASSEMBLING OUR PRODUCT.

**BEFORE YOU RETURN THE PRODUCT TO THE STORE,  
PLEASE CALL US TOLL FREE FOR CUSTOMER SERVICE ASSISTANCE**

**(888) 777-8250**

**OR SEND US EMAIL AT**

**[help@spartakent.com](mailto:help@spartakent.com)**

PLEASE HAVE ITEM NUMBER READY, AND A REPRESENTATIVE WILL GLADLY ASSIST YOU



# PARTS IDENTIFICATION

NOTE: FIRST MAKE SURE THAT YOU HAVE ALL OF THE PARTS LISTED ON THIS SHEET. IF YOU ARE MISSING ANY PIECE(S), DO NOT ASSEMBLE THE UNIT. INSTEAD, CALL OUR CUSTOMER SERVICE NUMBER AT: (888) 777-8250. WE WILL BE HAPPY TO ASSIST YOU.

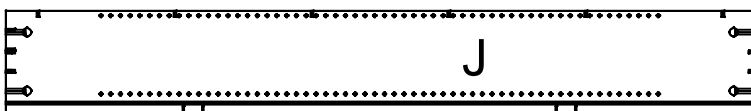
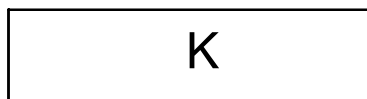
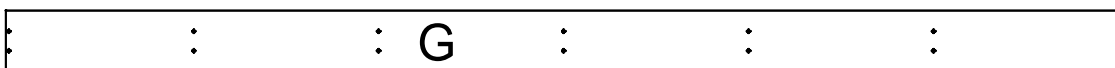
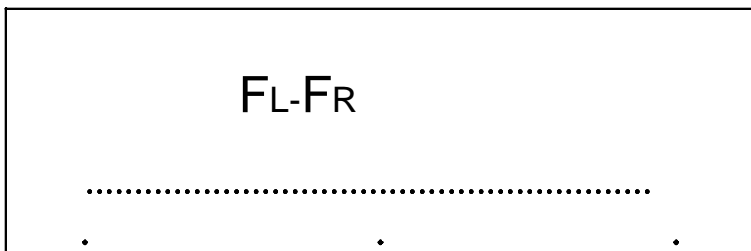
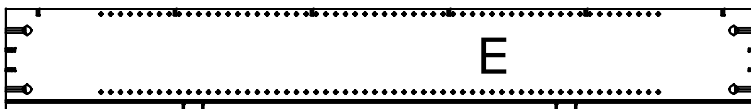
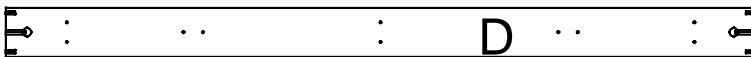
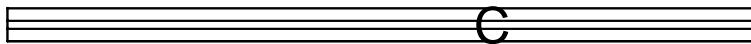
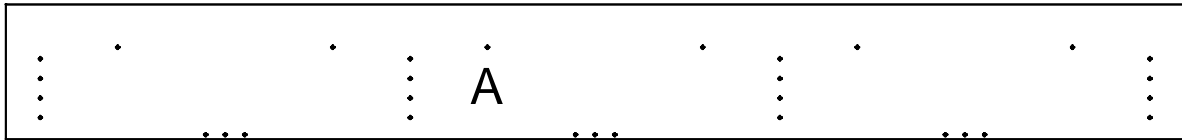

2403A-Top	1pc	2401FL-Back Panel	3pcs
2403B-Base	1pc	2401FR-Back Panel	3pcs
2401C-Molding	4pcs	2403G-Stretcher	1pc
2401D-Back Support	3pcs	2411K-Shelf	21pcs
2401E-Outer Side	2pcs	2401I-Brace	3pcs
		2402J-Inner Divider	2pcs

**PARTS ARE USUALLY MARKED ON THE RAW EDGE.**

HARDWARE	PART #	DESCRIPTION	QTY
	SFH845A	WOOD SCREW	16
	BM25	BRACKET ANGLE	6
	SPE610BL	EURO SCREW	12
	BPXX54	SHELF SUPPORT	126
	DOWW525	WOOD DOWEL	56
	CAMLT12	CAMLOCK	22
	CAMBT16	BOLT	22
	SPB1016BL	PAN HEAD SCREW	24
	GLUEWD	WOOD GLUE	1
	CCPZXX	CAMLOCK COVER CAP	16
	SHPL5	SHELF LOCK	42

TOOL REQUIRED

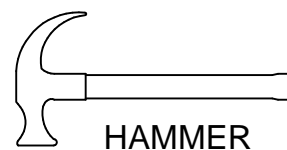
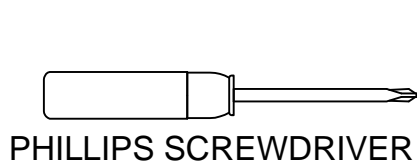

1

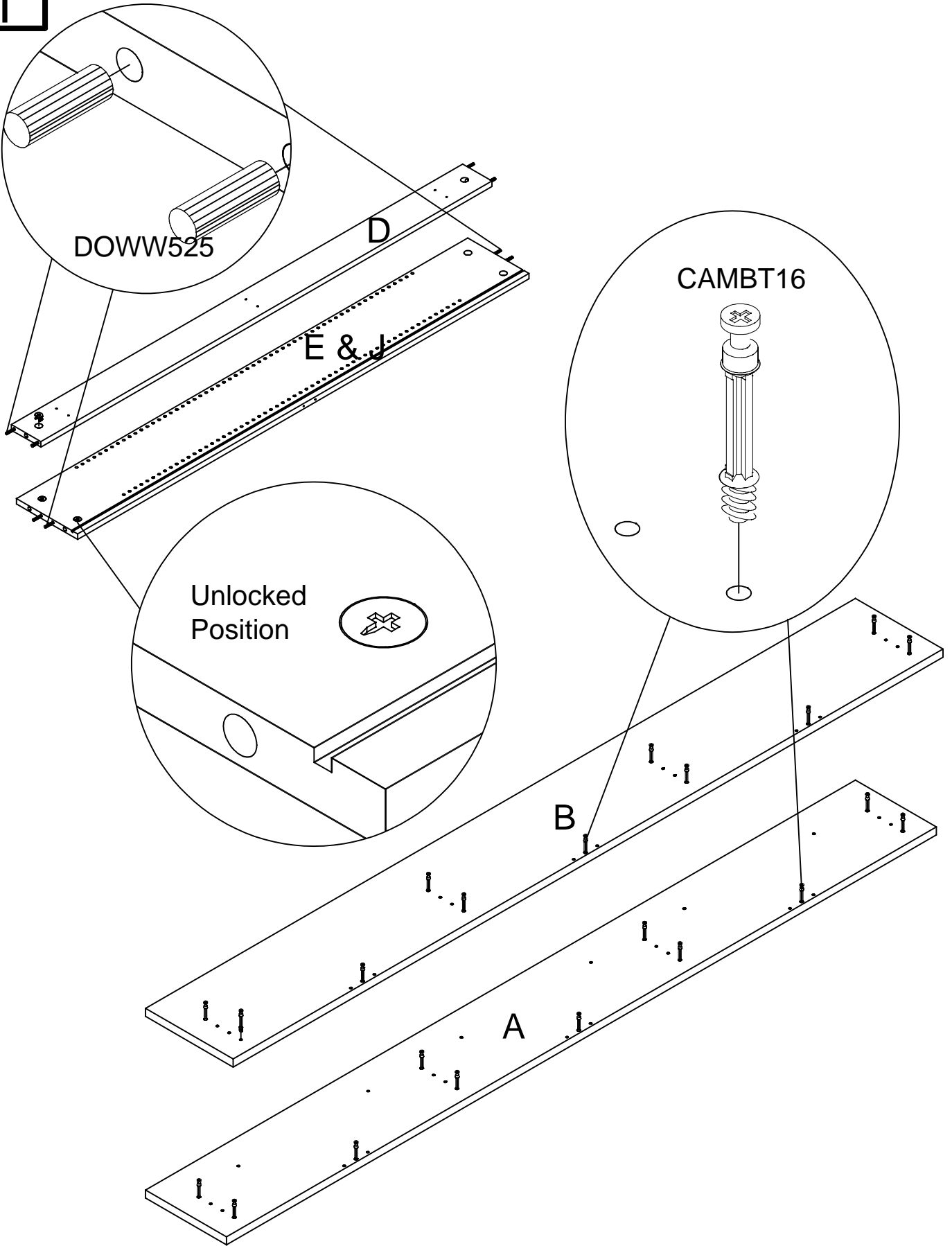

2

Make sure groove on parts E and J should be located at the bottom edge. If it's not then you had installed it upside down.

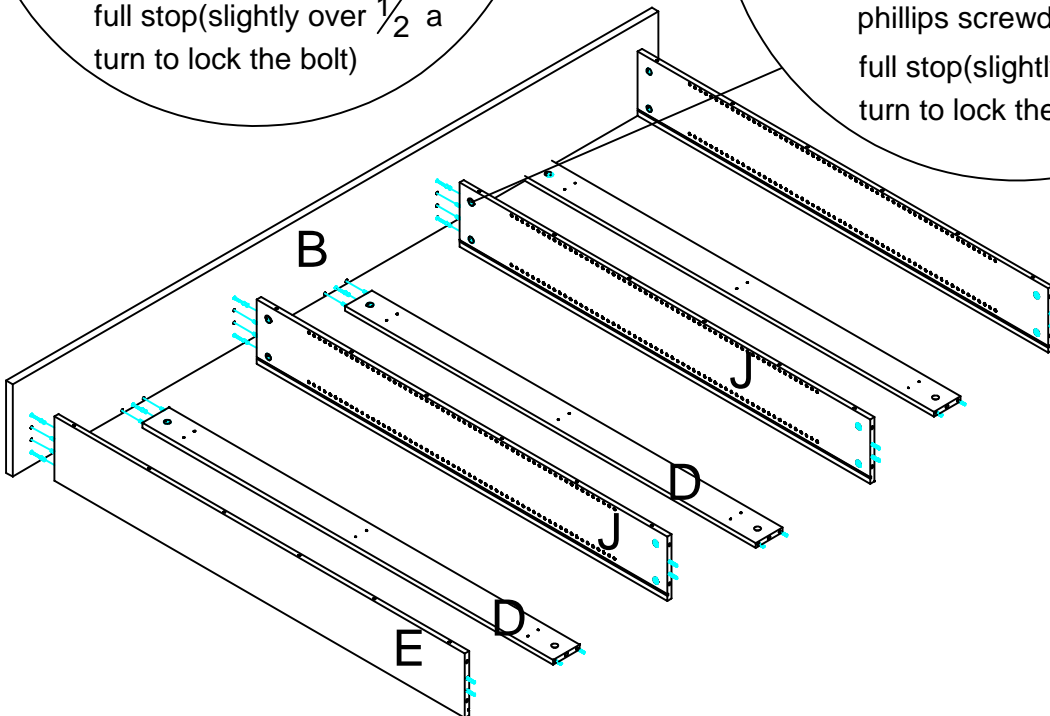
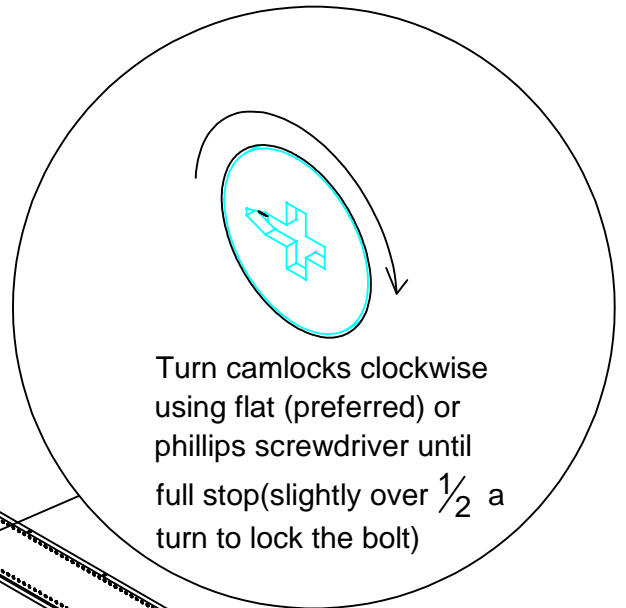
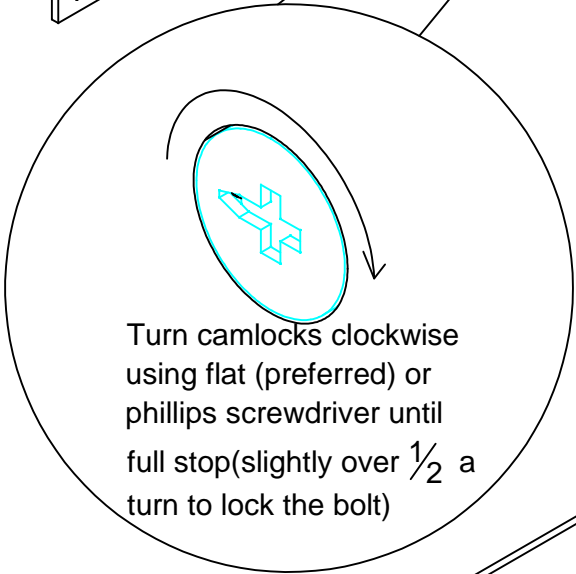
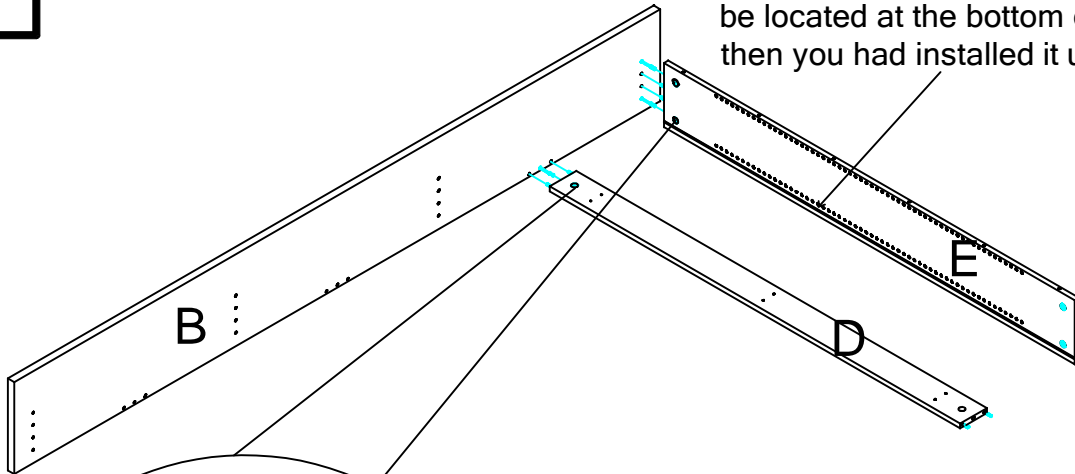

3

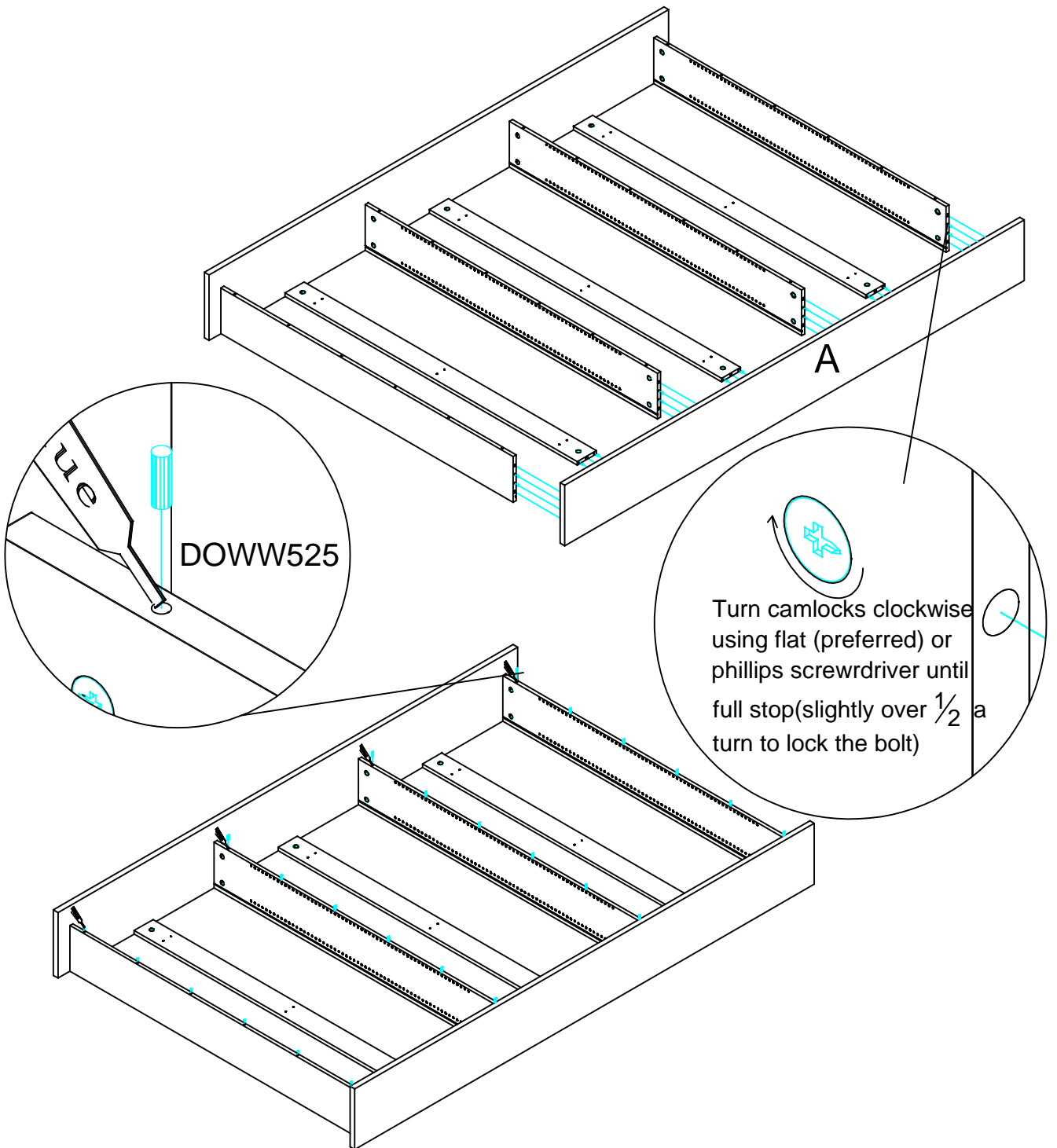

Make sure the dowels go in as far possible. They should stick out no more than 3/8 of an inch.

Do not use more than one drop of glue as it may cause board to split.

4

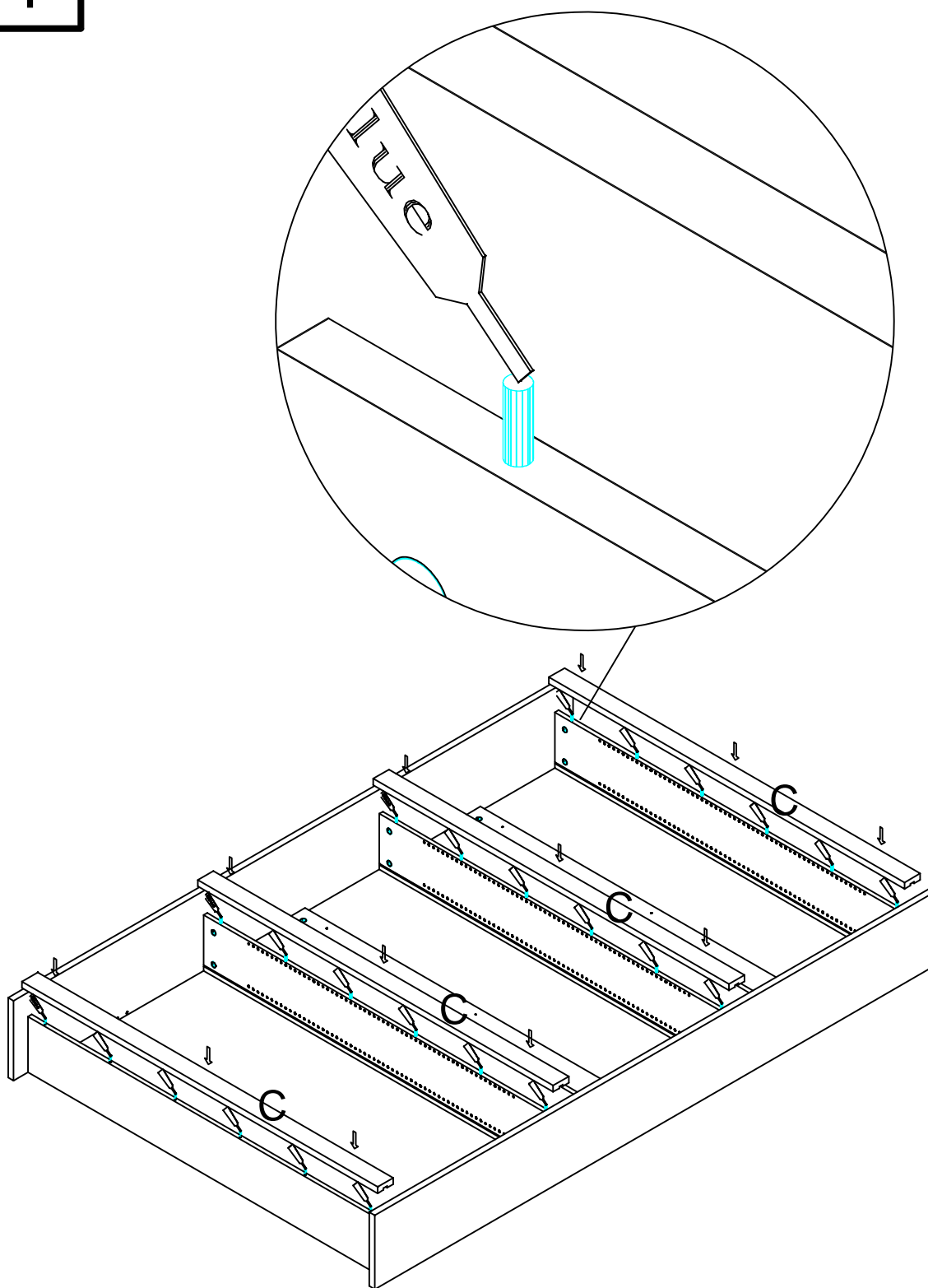

5

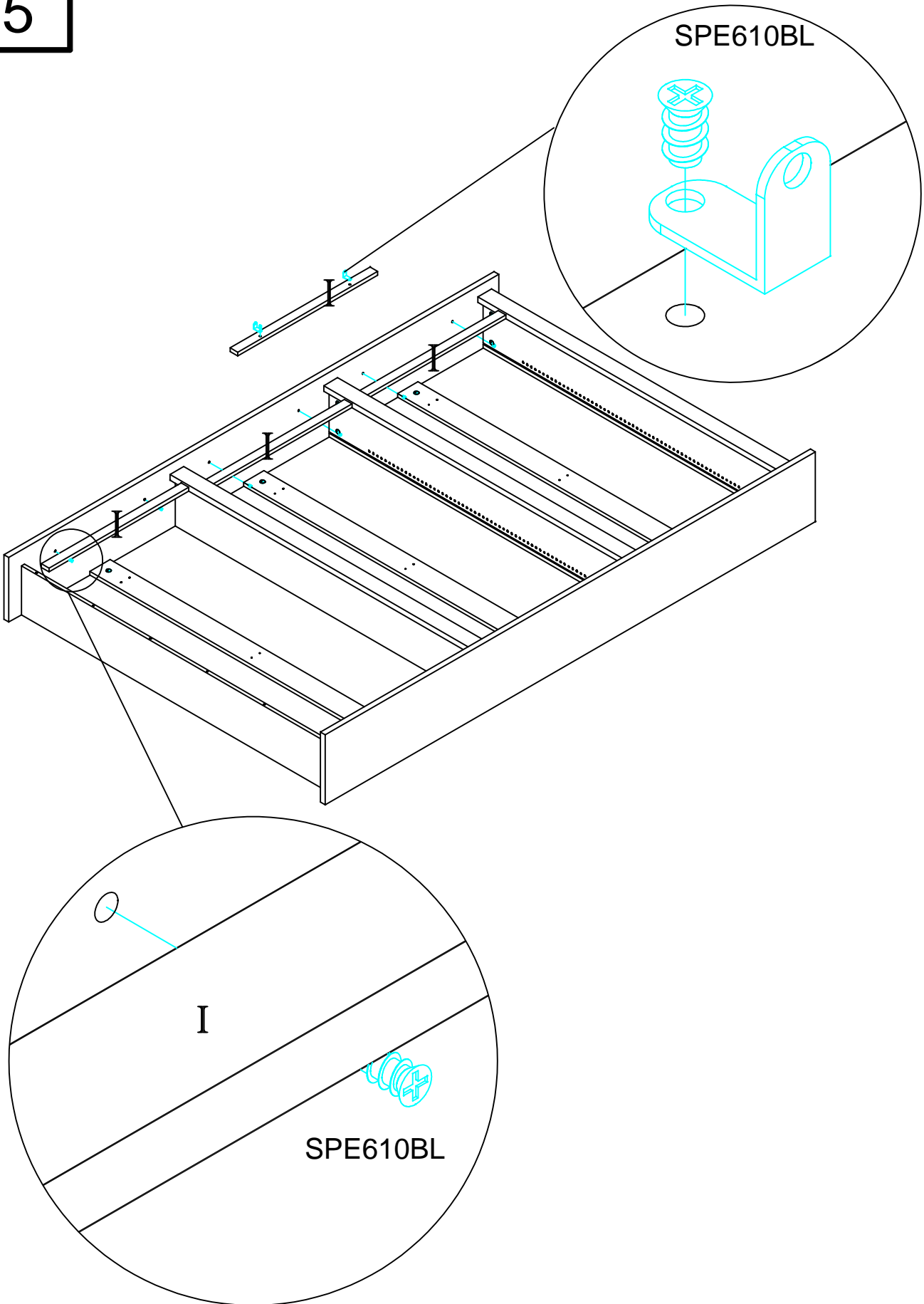



6

Use small screws on the back panel between Outer Sides(E) and dividers (J).

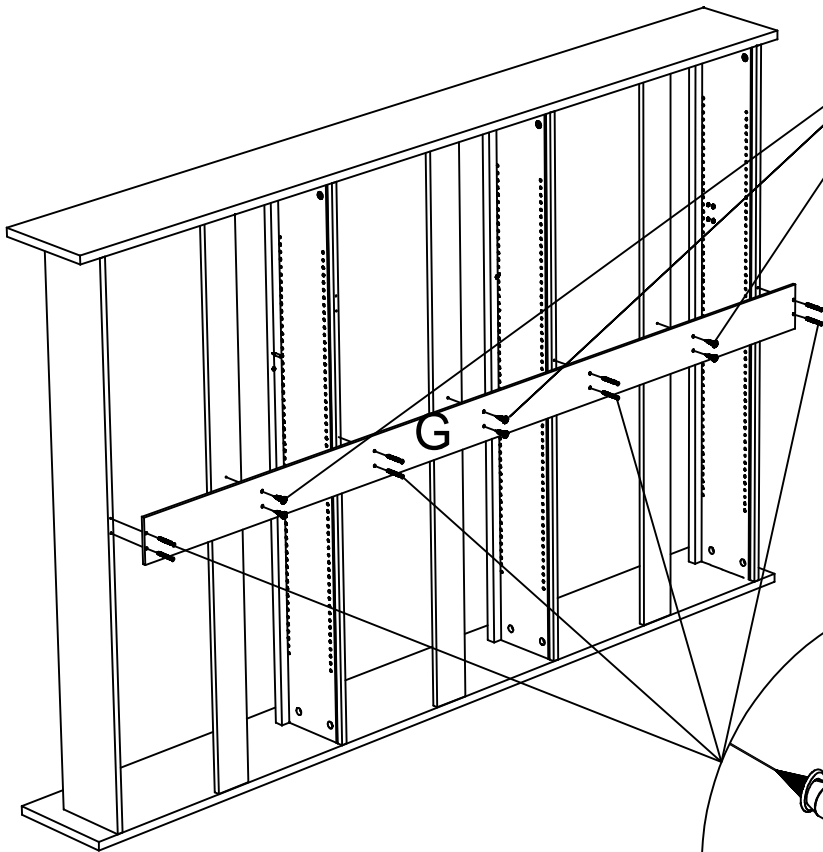
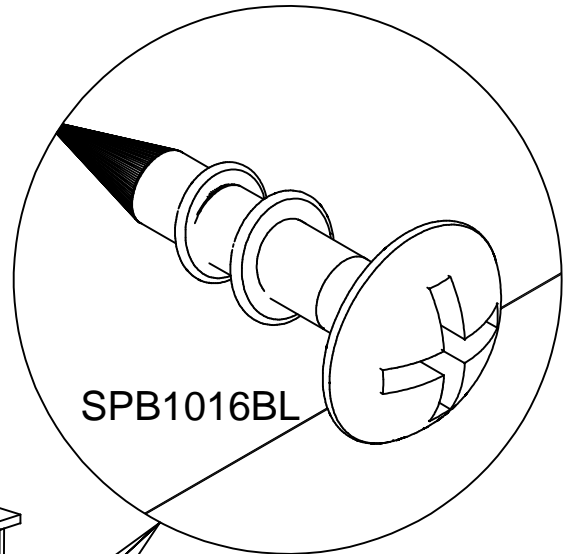

Use long screws only on the Outer Sides(E) and dividers (J).

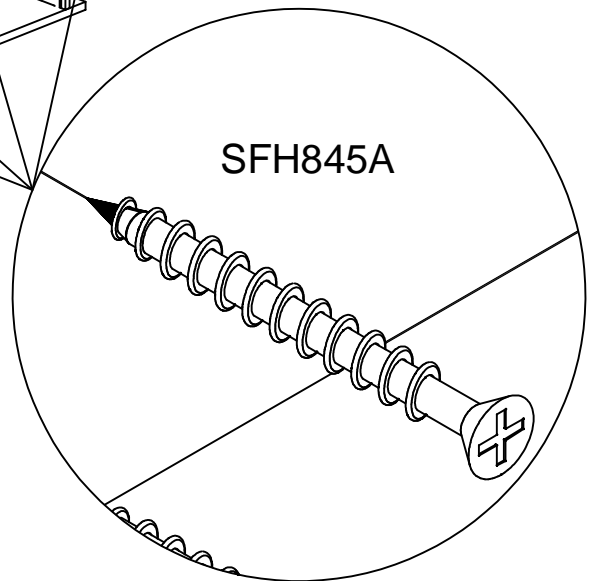

7

Install Back Panels as shown, with unmarked edges facing down and blue or red marked being atop. Make sure the Blue is on the left side and Red is on the right side of each section. Otherwise you will have problem with leveling of the shelves, they will sag in the middle.

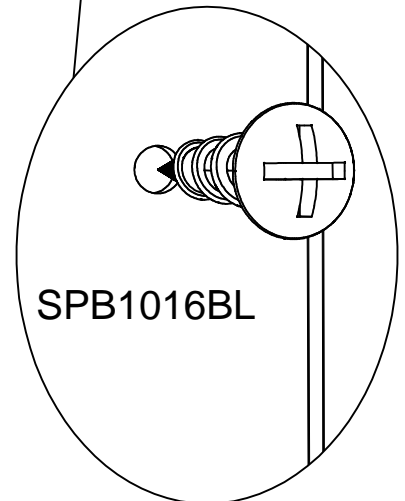

SPB1016BL

8

Do not tap with hammer onto shelf supports, instead twist them when inserting in. You will be using six shelf supports per shelf, two on each side and two in the back.

Install shelves at desired locations. Use a case of CD or DVD as a template to locate positions for the shelves. Start from the bottom. If you skip a hole or mix in one section with CD or DVD/VHS cases, you may end up with some unused space at the top. In other words, to get the maximum capacity, don't skip any holes or mix different kinds of media in one section.

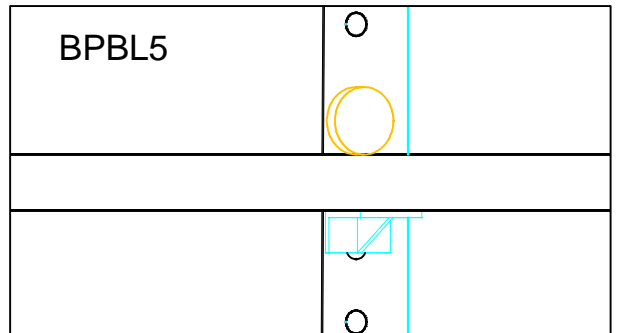
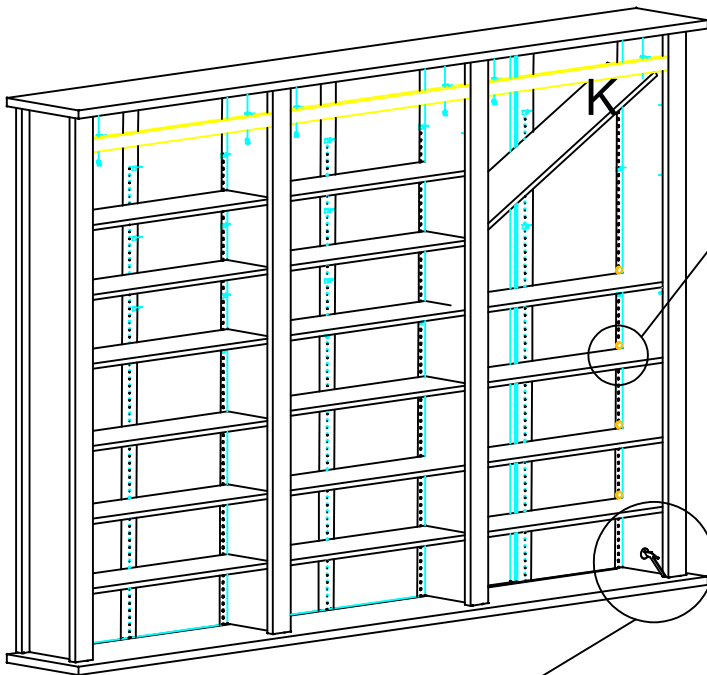

To prevent shelves from sagging, lock the back corners of them from above with two shelf supports.

