



IF PARTS ARE MISSING AND OR DEFECTIVE, IF INSTRUCTIONS ARE NOT CLEAR
OR IF YOU ARE EXPERIENCING PROBLEMS ASSEMBLING OUR PRODUCT.

**BEFORE YOU RETURN THE PRODUCT TO THE STORE,
PLEASE CALL US TOLL FREE FOR CUSTOMER SERVICE ASSISTANCE**

(888) 777-8250







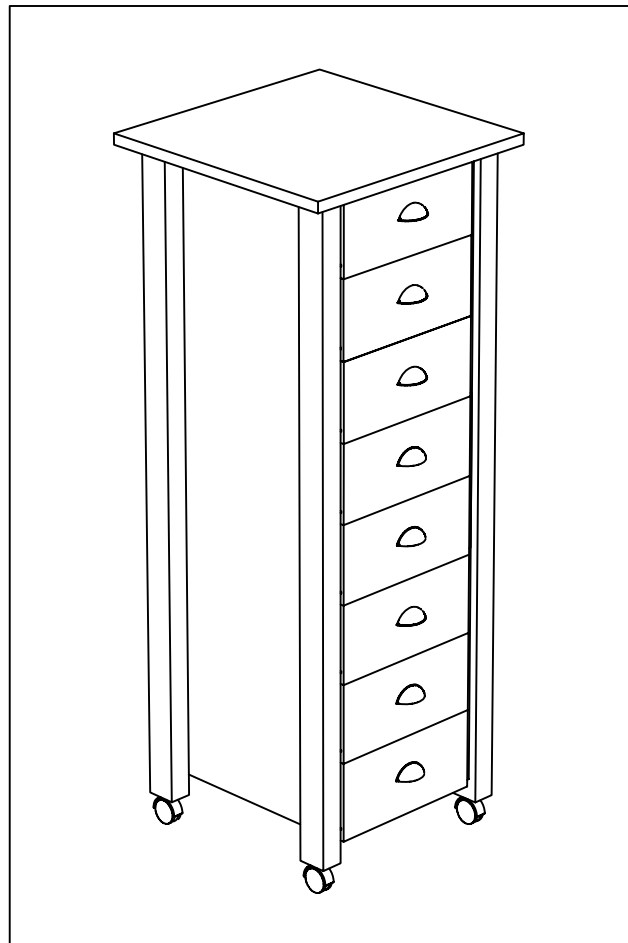

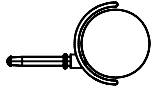

OR SEND US EMAIL AT

help@spartakent.com

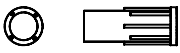
PLEASE HAVE ITEM NUMBER READY, AND A REPRESENTATIVE WILL GLADLY ASSIST YOU



HARDWARE LIST

HARDWARE	PART NUMBER	DESCRIPTION	QTY
	CAMLT12	CAMLOCK	4
	CAMBTQF	QUICKFIT BOLT	4
	DOWW830	1-1/4 LONG WOOD DOWEL	4
	CAS40S	40mm CASTER W/STEM	4
	PUSH	SHELL METAL PULL	8
	CAS40SIN	40mm CASTER W/STEM INSERT	4
	SRM815B	MACHINE SCREW	16
	GLUEWD	GLUE	2
		BLOCK	1
	SFH833A	WOOD SCREW	4
	SC-S	SCREW COVER CAP	4

TOOL REQUIRED

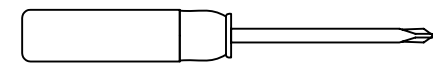

PHILLIPS SCREWDRIVER

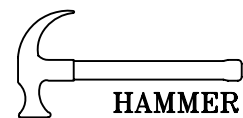

HAMMER

PARTS IDENTIFICATION

NOTE: FIRST MAKE SURE THAT YOU HAVE ALL OF THE PARTS LISTED ON THIS SHEET. IF YOU ARE MISSING ANY PIECE(S), DO NOT ASSEMBLE THE UNIT. INSTEAD, CALL CUSTOMER SERVICE NUMBER AT: (888) 777-8250. WE WILL BE HAPPY TO ASSIST YOU.

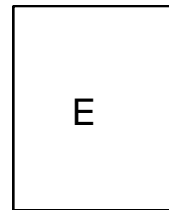
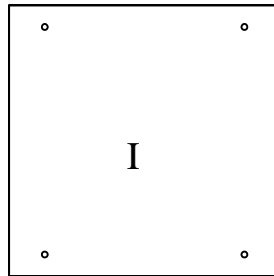
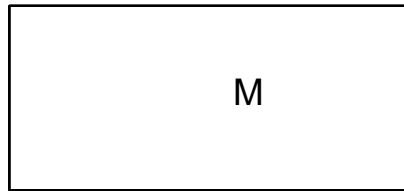
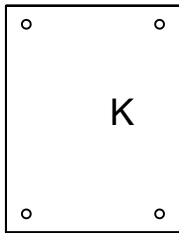
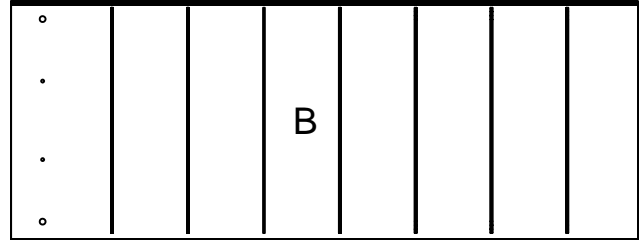
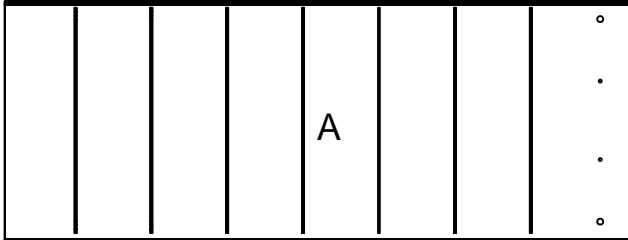

4057A-Left Side	1pc
4057B-Right Side	1pc
1017D-Drawer back	8pcs
1010E-Drawer bottom	8pcs
1010F-Dr. Sides & Front	8pcs
1010G-Rail	8pcs

4047I-Top	1pc
1017K-Bottom	1pc
4057M-Back Panel	1pc

PARTS ARE USUALLY MARKED ON THE RAW EDGE.

1

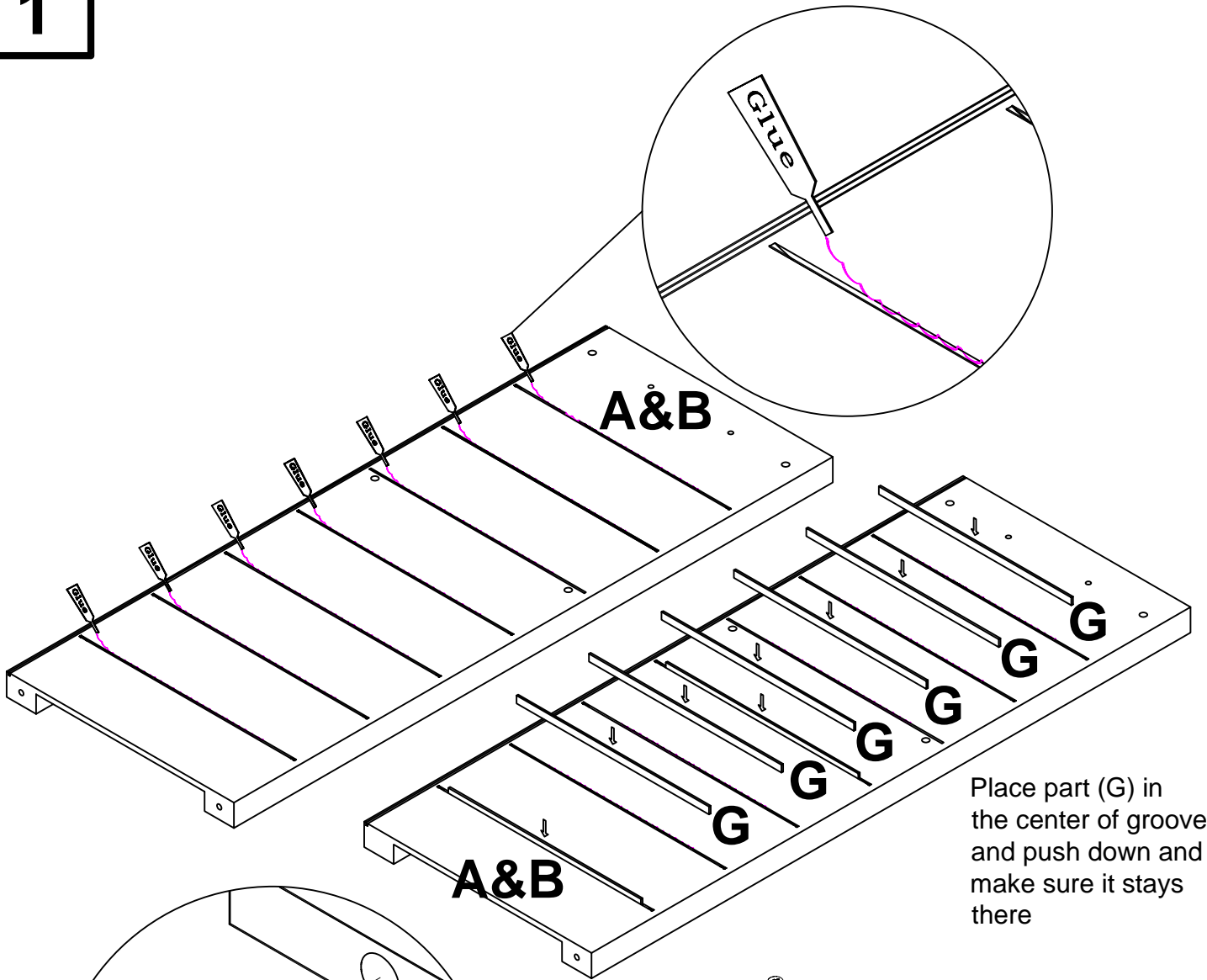

Place part (G) in the center of groove and push down and make sure it stays there

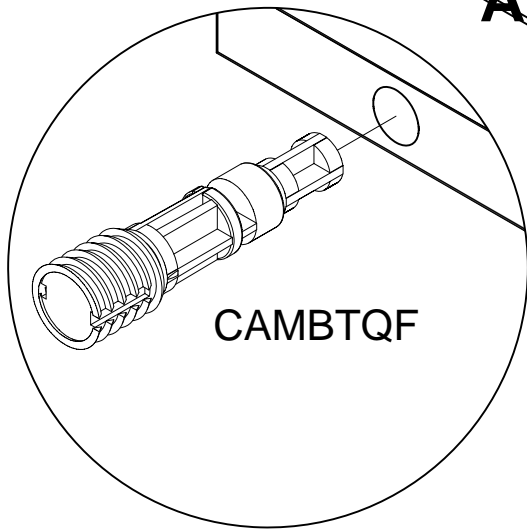

CAMBTQF

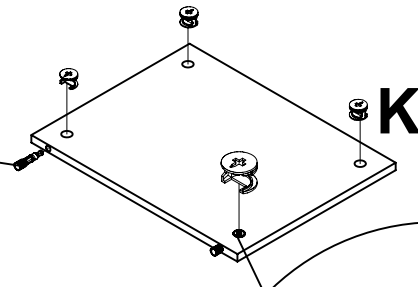

K

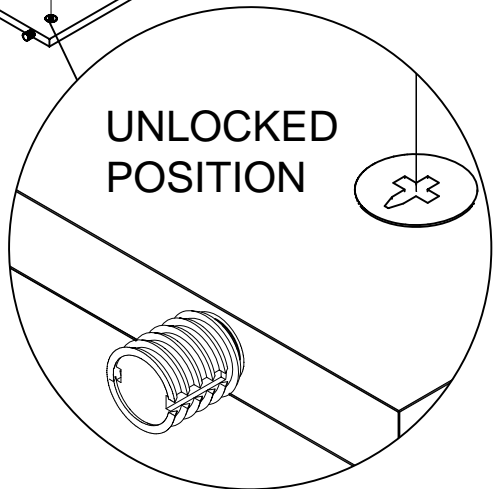

UNLOCKED POSITION

Leave parts (A&B) on the floor to allow the glue to set for at least 30 minutes. In the meantime you can assemble the drawers.

2

We recommend you do one drawer at the time.

The excess of glue can be wiped off with a damp cloth. Also, once glue sets it will turn translucent and it will not stick to laminated surface and can be easily peeled off.

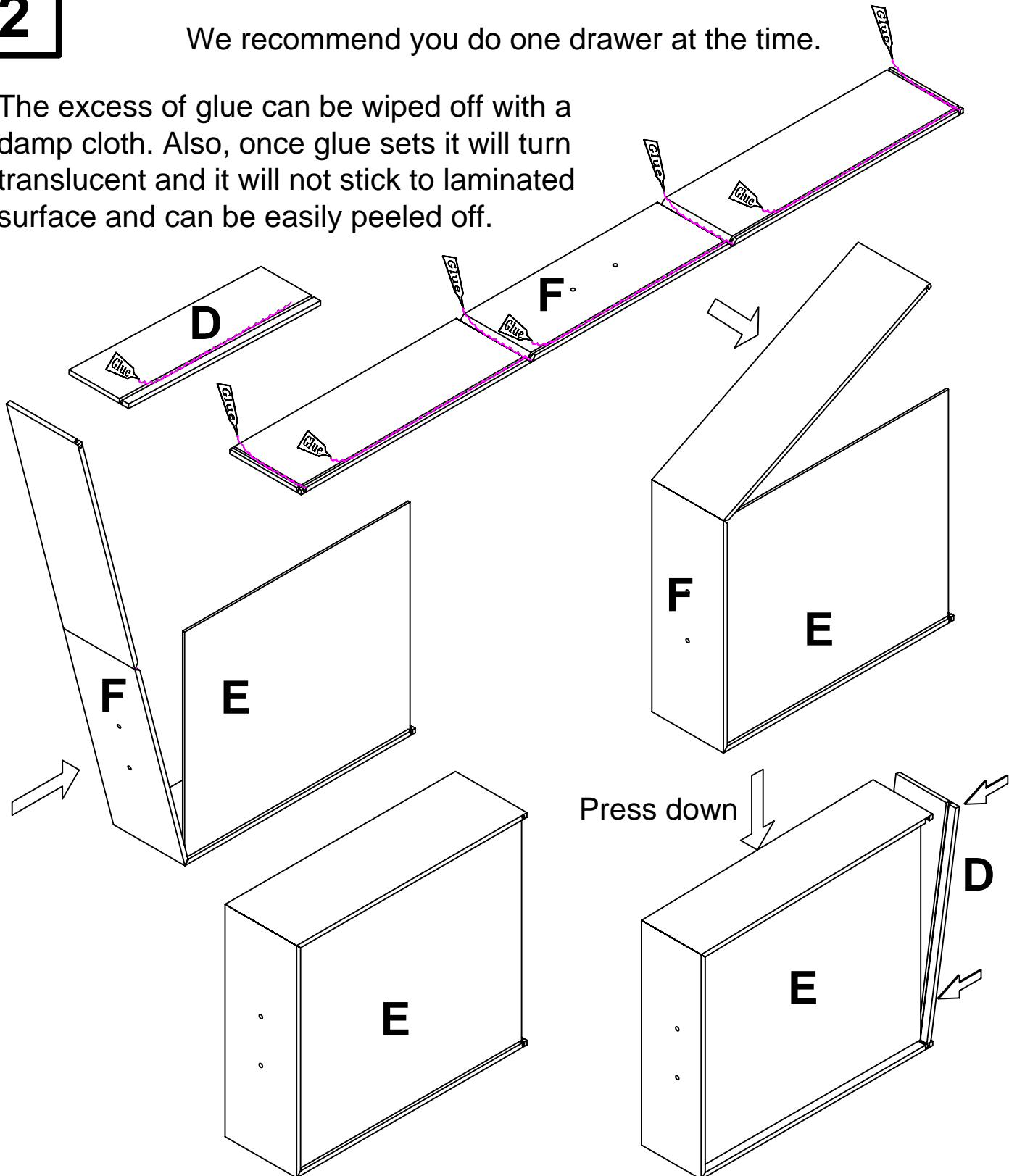

Allow glue to set at least for 2 hours. Repeat this step for the other four drawers. Make sure drawer back fits snug and there are no gaps. Leave drawers on their side until glue has set. You may put weight on it, like couple of books to apply pressure. In the mean time you can complete assembly of the frame of the workstation.

3

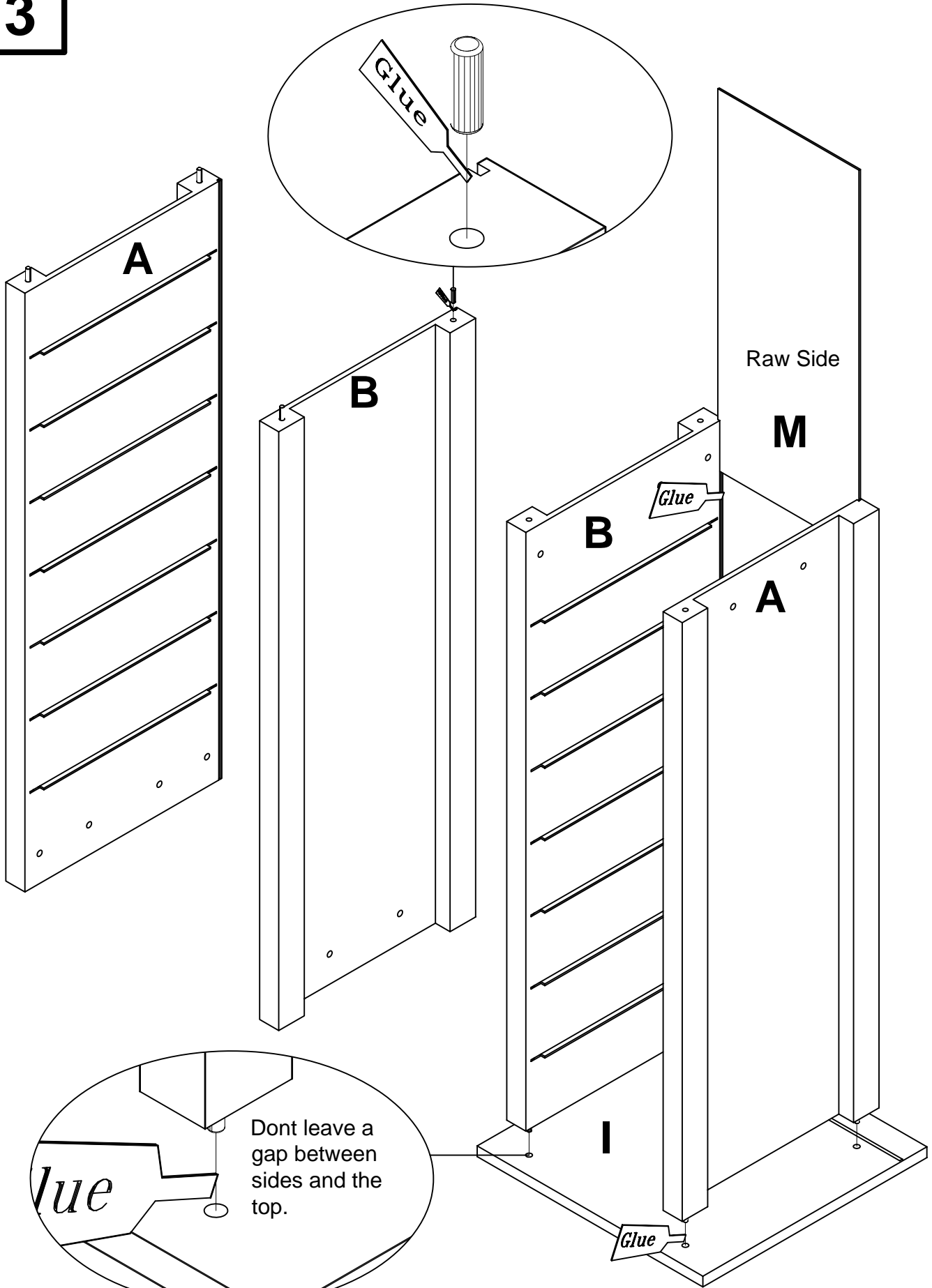

4

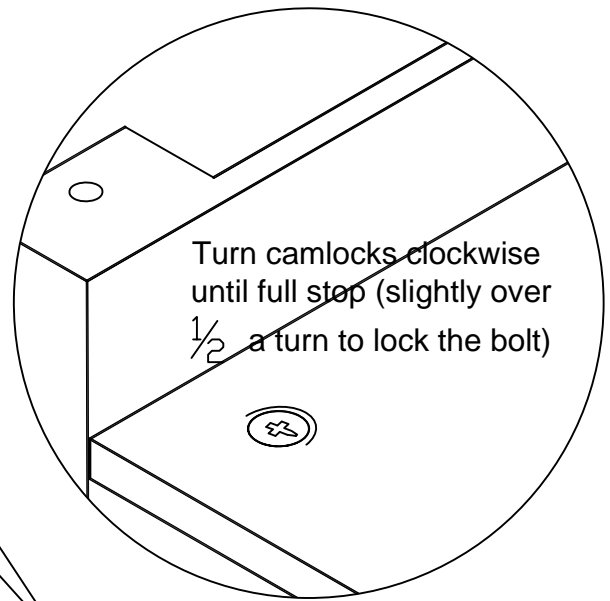
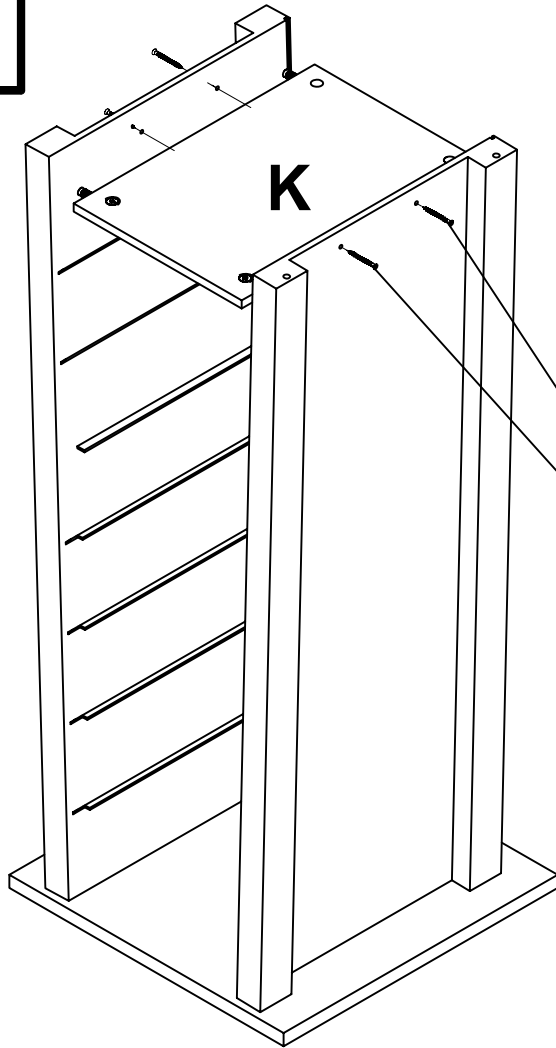

Turn camlocks clockwise until full stop (slightly over $\frac{1}{2}$ a turn to lock the bolt)

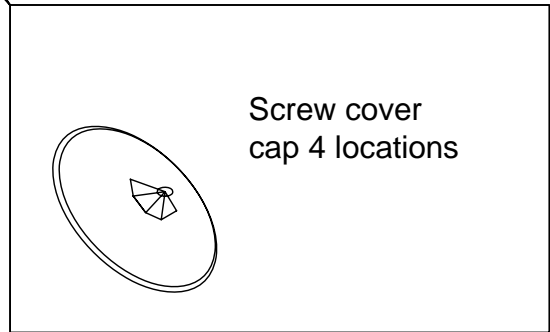

Screw cover cap 4 locations

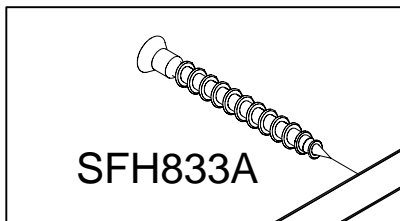

SFH833A

1. Insert part (K) onto part (A) then open the unit as much as you need to fit the part (K).

2. Push the sides (A&B) together. Make sure leave no gap between parts.

3. Lock camlocks by turning clockwise until full stop (slightly over $\frac{1}{2}$ a turn to lock the bolt).

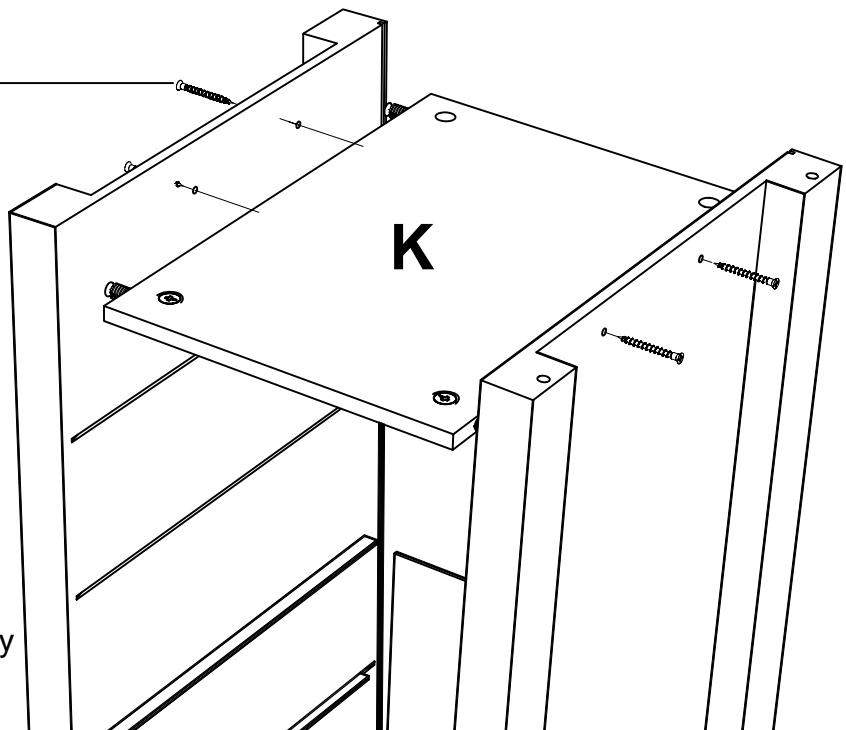

5

Use block provided in hardware kit.

Locking casters install in the front.

Tap in plastic inserts in first.

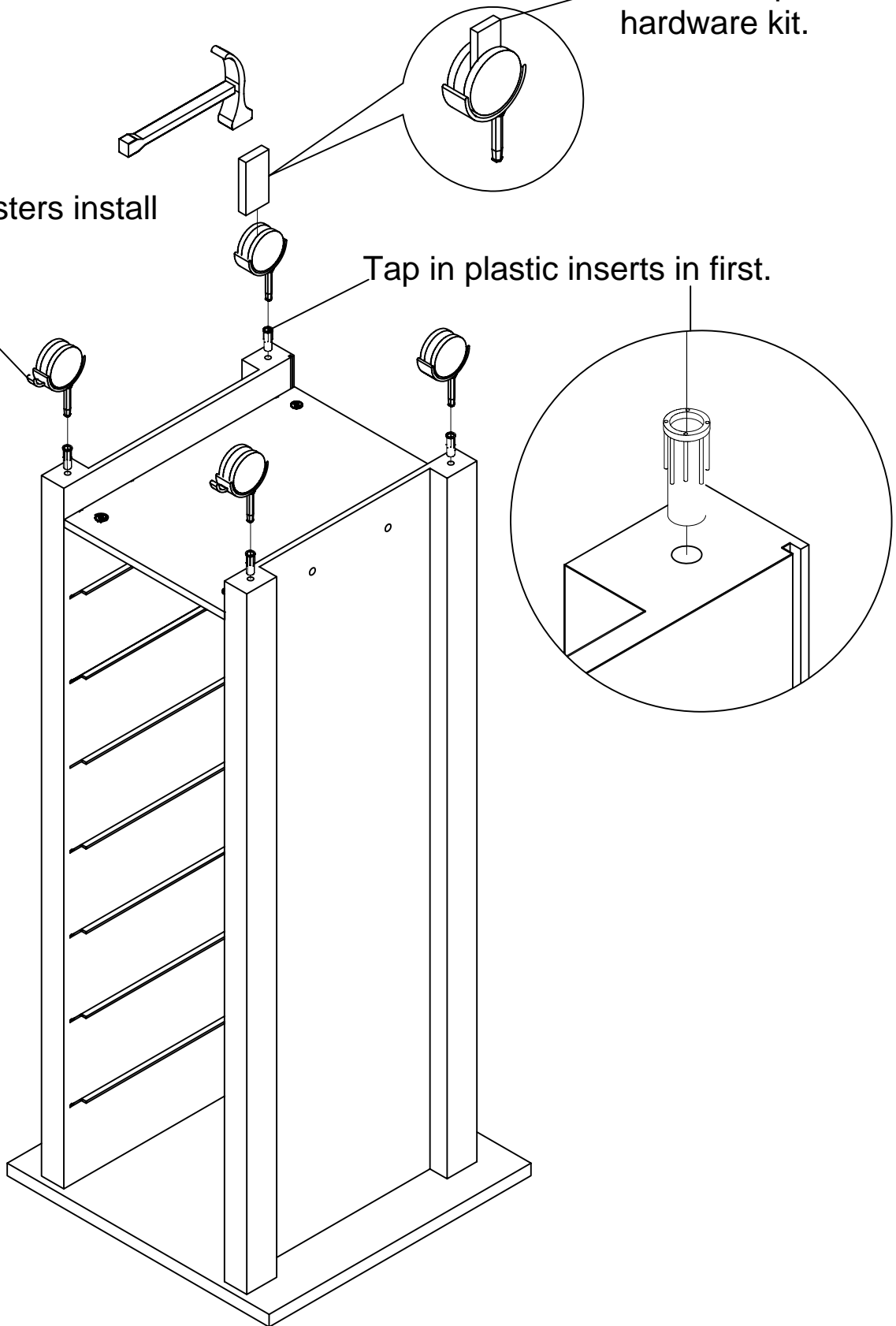

6

