



Essex LED Mini Pendant SXPL Series

Features

This hand blown glass pendant utilizes LED low voltage technology in a compact drop shape. Glass is 5" high x 4-1/4" in diameter and is available in several color choices. Light engine includes LED module L70 rated at 35,000 hours. Pendant is suspended from 8' coax cable that can be cut to height and retained with a set screw and strain relief bushing. Product can be used over receptions desks, restaurants, and in any task lighting application. Driver is located in the canopy which mounts to standard junction box (not included).

Construction

Glass is supported with a 1/8" IP threaded stem and jam nut. Canopy is \varnothing 5-1/4" x 1-5/8" deep fits over a standard junction box. Canopy is retained to the junction box from the inside with 2 mounting screws and the cover is retained with a strain relief. Power supply connections must be made inside a junction box (not included).

Finish

All exposed metal parts are plated satin nickel or rubbed bronze with clear lacquer topcoat.

Diffuser

Diffuser is 3/16" thick hand blown case glass which is available in amber, blue, red, or white.

Electrical

This unit is direct wired with a 500mA low voltage electronic LED driver located in the canopy. The constant current LED driver is rated for 12W with a constant voltage of 120 VAC/60 Hz. 120-277V universal-voltage (non-dimmable) driver (MV) or 120V line-voltage 2-wire dimmable driver (D1).

Lamping

All pendants include a 6W LED module. Light engine produces 450 lumens. Standard color temperature 2700K or 4000K.

Certification

All fixtures are cETLus listed for damp locations

Project		Fixture type
Location		Quality
Approved By	Date	Catalog Number

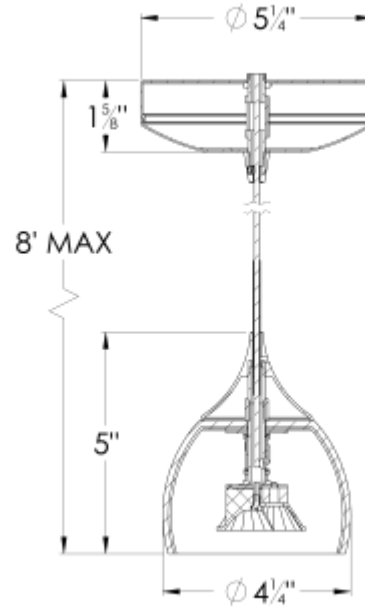

Ordering Information:

Model No.	Finish	Lamping	Diffuser	Dimensions (overall)
SXPL45027AMRB	Rubbed Bronze	6W LED	Amber glass	5" H adj" L 4.25 DIA