

1509W Wood Roof for Clatter bridge running change 2015

Dear Customer,

We are doing a running change to our Clatter Bridge. Your playset was probably shown having a Tarp Roof. For 2015 we are upgrading the clatter bridge to have a wood roof if the main fort of the play set has a wood roof. Please use the pages attached to inventory and assemble the Wood Roof on your clatter bridge.

Please disregard any steps in the manual referring to the tarp roof on the clatter bridge.

Your hardware kit for the clatter bridge will consists of a 1509N kit and a 1509W kit. The 1509N hardware list is after this page. The 1509W kit is shown in the Clatter Bridge Wood Roof instructions that are attached.

Thank you.

11-0071
1509N HARDWARE
PAGE: 1 OF 1
REV A: 9/19/2014 JH

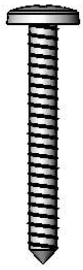

#14 x 1-1/4"
PAN HEAD SCREW
QTY: 6

#8 X 2"
WOOD SCREW
QTY: 94



#8 X 2-1/2"
WOOD SCREW
QTY: 18



#8 X 3"
WOOD SCREW
QTY: 5

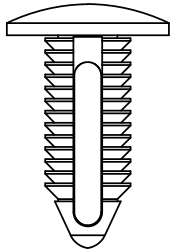

3/8" ϕ X 1-1/8"
BLACK PLASTIC
PLUG
QTY: 4

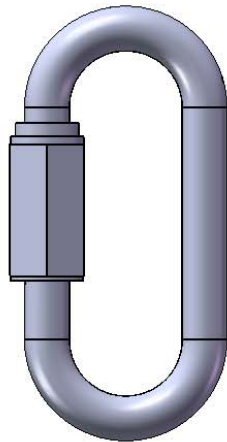

QUICK LINK
QTY: 2

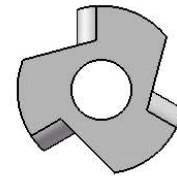

5/16" TEE NUT
QTY: 55

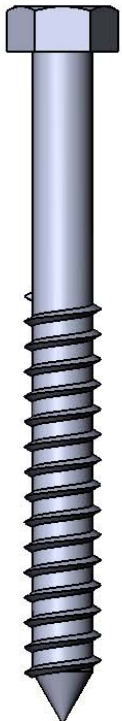

5/16" X 3-1/2"
HEX LAG
SCREW
QTY: 26



5/16 X 1-3/4"
HEX BOLT
QTY: 30

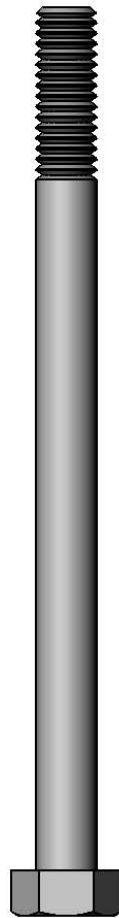

5/16 X 4-1/2"
HEX BOLT
QTY: 25

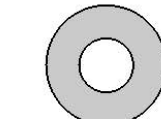

1/4" WASHER
QTY: 6

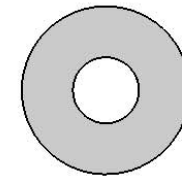

5/16" WASHER
QTY: 111

9
8
7
6
5
4
3
2
1

USE THE RULER TO THE RIGHT TO MEASURE YOUR BOLTS AND SCREWS. PICTURE VIEWS SHOWN ABOVE ARE 1:1 SCALE AND CAN BE USED TO MATCH BOLT AND SCREW SIZES.

Clatter Bridge Wood Roof Add On Kit

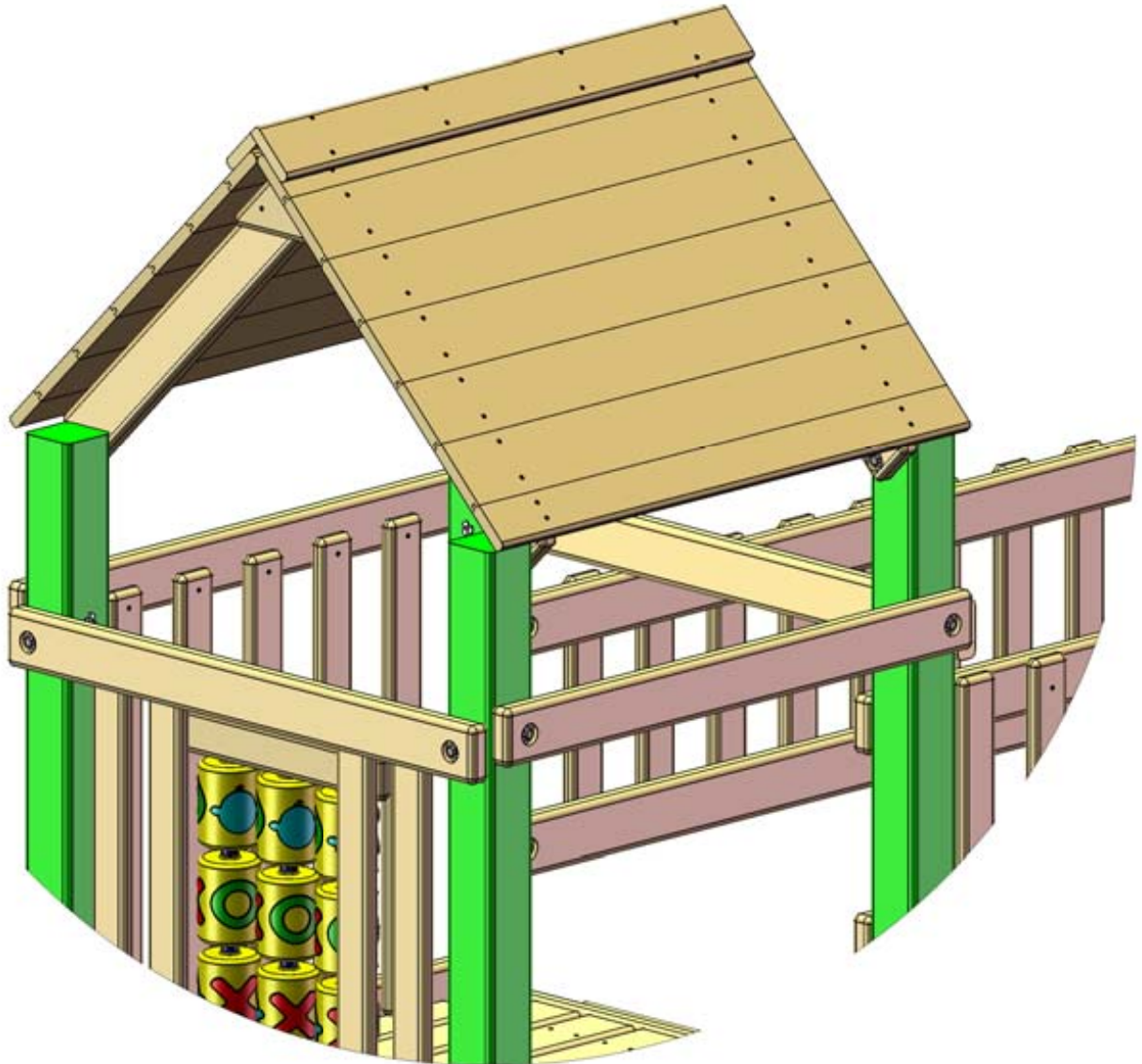

Note: 1509 Clatter Bridge and Accessories sold separately or are included with your play set.

Model: 1509W

(BOXES: 1509W wood box,
1509 Hardware Box)

REV: 3.12.2015

TABLE OF CONTENTS

General Information.....	Page 3
Definitions.....	Page 4
Board Identification.....	Page 5
Pre-Drill Lag Screw Directions.....	Page 6
Tool List and Kit Contents.....	Page 7
Hardware and Wood Lists.....	Pages 8-9
Roof Support Assemblies.....	Step 1
Drilling Corner Post Holes.....	Step 2
Install Roof Support Assemblies.....	Step 3
Roof Starters.....	Step 4
Roof Peak Assembly and Installation.....	Step 5
Roof Boards and Roof Finishers.....	Step 6

**PLEASE READ OWNER'S MANUAL CAREFULLY
BEFORE STARTING ASSEMBLY!**

General Info to Review Before Installation

- Depending on your experience, assembly of the playset can take as little as 6 hours up to 24 hours, depending on size, after inventory of parts; therefore, we recommend you set aside a full two days for assembly.
- Identify all of the parts for your play set. Empty each box and lay out boards so you can see each part. Your instruction book will have detailed drawings that will make it easy for you to recognize individual parts. Keep all hardware and metal parts separate from wooden pieces.
- After everything is laid out, check carefully to ensure all parts are present. Make sure there are no broken boards.
- Find an area to sort your hardware. It is best to open the hardware on a solid surface so that you do not lose any pieces in the grass. This will save time and familiarize you with all the different pieces in the hardware bag.
- Important note: Wood has some natural defects such as knots, surface cracks, etc... We reject parts that are structurally defective. We use a high quality lumber in our structures; however, you should inspect each part for splinters or rough spots and sand them smooth to prevent injury.
- After familiarizing yourself with all of the components, read all instructions thoroughly. Reading instructions after you have studied the parts will help you understand the installation process, and help to eliminate unnecessary mistakes.
- Pay close attention to the diameter and length of each bolt and screw.
- Never tighten hardware completely at first. It helps to have some adjustment for bolt alignment while you are attaching parts together. After everything is square, tighten each joint.
- After the main unit is assembled it is critical that the floor is level and square. If the main frame is not level, the walls and floor will be out of square.
- After you complete installation, make sure every bolt, screw, and nut is tight, and every board is secure. Wood will expand and contract with the seasons.
- Place the set on level ground, not less than 6 feet from any structure or obstruction such as a fence, garage, house, overhanging branches, laundry lines, or electrical wires.

This page is a list of definitions and explanations used throughout our instructions to aid you in the assembly of your play set.

Offset Holes- Throughout the installation procedures we will refer to parts with offset holes. This refers to the orientation of the holes on the board. An offset hole is one that is closer to one side than it is the other or in other words, it is not centered on the board. In the procedures you will be instructed to attach the boards with the holes offset up or with the holes offset down. This refers to which side of the board the hole/holes should be closer to. Offset holes up= hole/holes will be closer to the top of the board. Offset holes down= hole/holes will be closer to the bottom of the board. Note: some parts do not have offset holes, but instead the holes are on center. Therefore there will not be any reference on how to offset these parts.

EXAMPLE OF OFFSET HOLES UP

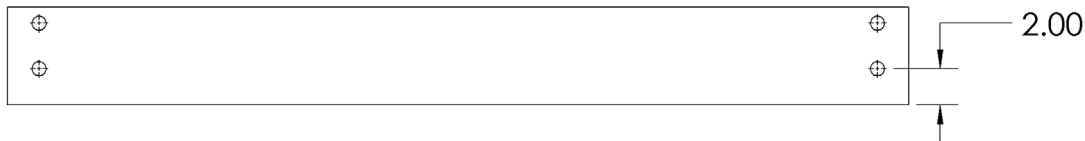

EXAMPLE OF OFFSET HOLES DOWN



Counter-sunk holes - Many of the parts that will be used have counter-sunk holes. A counter-sunk hole is one that surrounds one side of a through hole, but does not extend through the wood it's self. When using a counter-sunk hole the bolt will be inserted through the through hole and either the head of the bolt and washer or nut and washer will occupy the counter sunk hole.

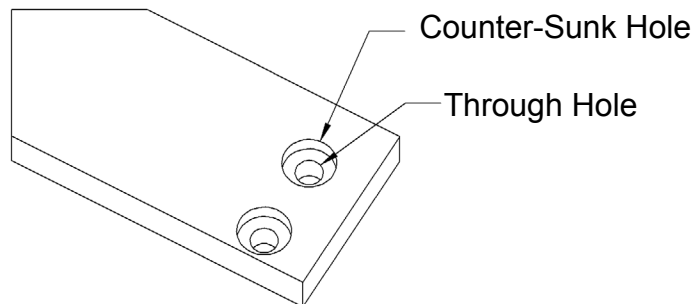

Lag Screws- Lag screws are used in the construction of our play sets to enhance the structural integrity of the unit. There will not be predrilled holes in the post for lag screw installation. Lag screws are self-tapping, though if you are using a manual socket wrench it may be advantageous to pre-drill a hole first. Instructions for this are provided on a separate page in the front of the manual. Be sure to tighten the lags completely when driving them in by hand. Power tools such as a heavy duty impact driver or large power drill should have enough torque to drive in the lag screws, but make sure not to over tighten as this can cause the threads to “strip out” in the post.

BOARD IDENTIFICATION

1. On the end of each board there should be a small white tag that is stapled into place.
2. This white identification tag displays the thickness, width, length and an abbreviated description of the part.

Example: a tag reads "2-4-3600-BPB"

- The 2 is the thickness of the board. "Nominal Lumber" at a home center will measure 1-1/2" for the thickness. We "remill" that lumber to 1-3/8" thick.
- The 4 is the width of the board. "Nominal Lumber" at a home center will measure 3-1/2" for the width. We "remill" that lumber to 3-3/8" wide.
Note: sometimes the width will be smaller than 3-3/8" because:
A) We need the width of the part to fit into a certain area of the play set.
B) We need the designation to be simple.
- The 3600 is the length of the board. It means the board is 36 inches long. If the code were 3625 then the board is 36-1/4" in length.
- The "BPB" abbreviation stands for "Bottom Panel Board". The wood part bill of materials in the instructions has a description which will match the abbreviation closely.
- In the event that there is no tag on a wood part measure the part then:
A) Use the measurements and compare them to the wood list at the front of the instructions to identify it.
B) Look at the holes on the wood part and compare them to the pictures in the wood list.
C) Look to see if the holes are centered or if they are offset up or offset down.
This should help you identify any parts that have missing tags. In the event that you cannot identify a board please email us for assistance.

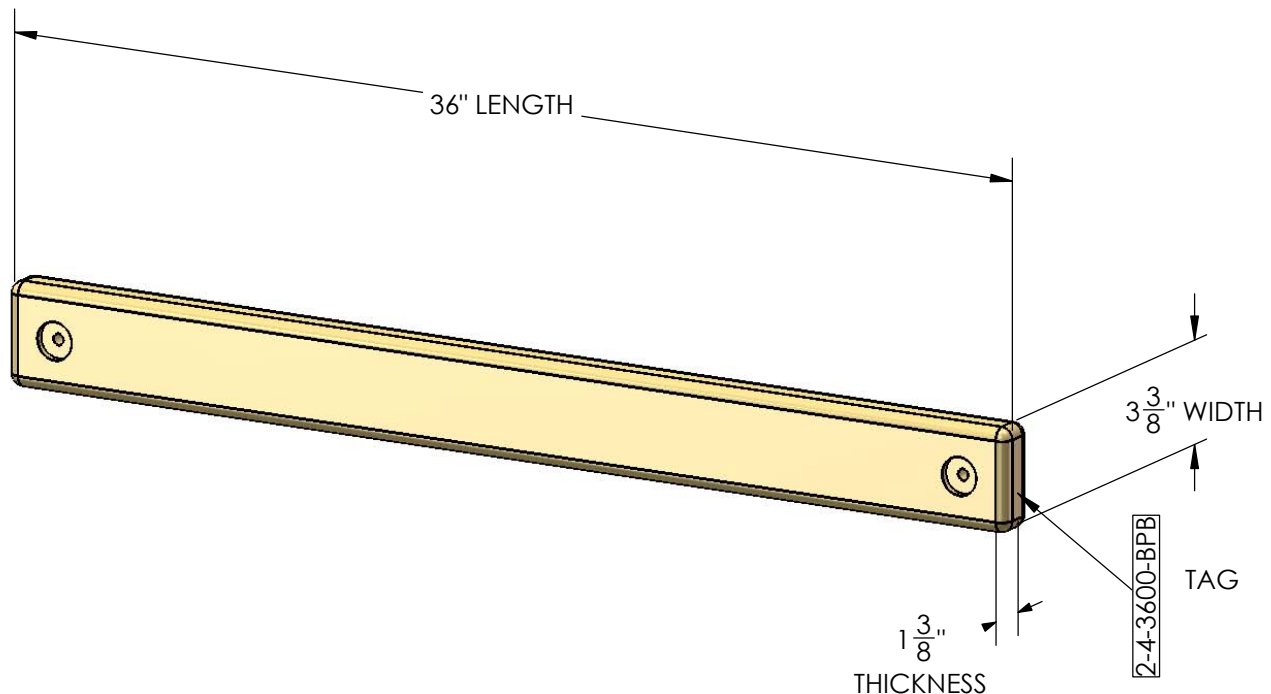

PRE-DRILL LAG SCREW DIRECTIONS

Pre-drilling holes for lag screws will make it easier to drive the screws in by hand. "Jobber" length drill bits are available in sizes that are longer than standard drill bits and those are ideal for the job. When using the drill bit you will have to "spot" drill the post and then remove the board you are attaching to finish drilling the hole.

Pay attention to the *DIAMETER* of the lag screw you are installing. Your playset may come with two different diameter lag screws. Each diameter will require a different size drill bit. When installing lag screws **DO NOT OVERTIGHTEN.**

LAG SCREW DIAMETER	DRILL BIT SIZE
5/16" DIAMETER	9/64"
3/8" DIAMETER	11/64"

Example: 3/8" diameter x 3-1/2" lag screw

This would be like the 2 x 4 board installation shown below. Place the board into position. Spot Drill through the holes in the 2 x 4 board into the corner posts with an 11/64" drill bit. Remove the 2 x 4 board. Continue to drill the holes to a total depth of 2-5/16" as shown at the right. Install the 2 x 4 board.

Example 5/16" diameter x 3-1/2" lag screw

This would be like the 2 x 4 board installation shown below. Place the board into position. Spot Drill through the holes in the 2 x 4 board into the corner posts with an 9/64" drill bit. Remove the 2 x 4 board. Continue to drill the holes to a total depth of 2-5/16" as shown at the right. Install the 2 x 4 board.

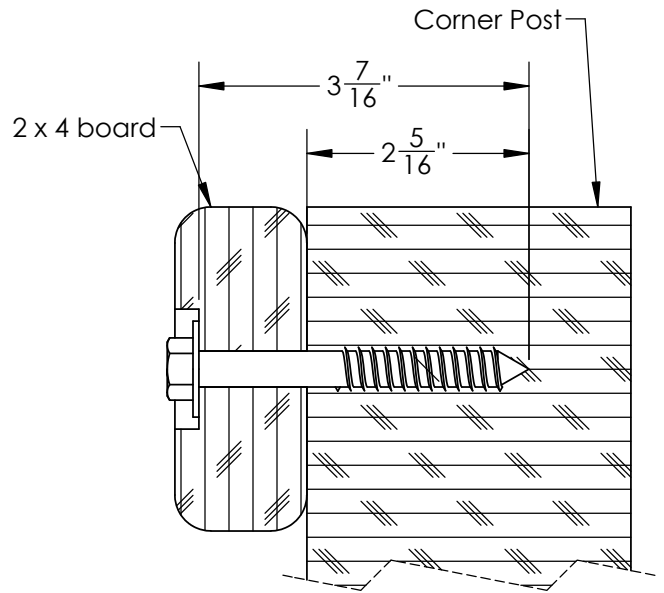

Example 3/8" diameter x 5" lag screw

This would be like the 4 x 4 board installation shown below. Place the board into position. Spot drill through the holes in the 4 x 4 board into the corner posts with an 11/64" drill bit. Remove the 4 x 4 board. Continue to drill the holes to a total depth of 2-13/16" as shown at the right. Install the 4 x 4 board.

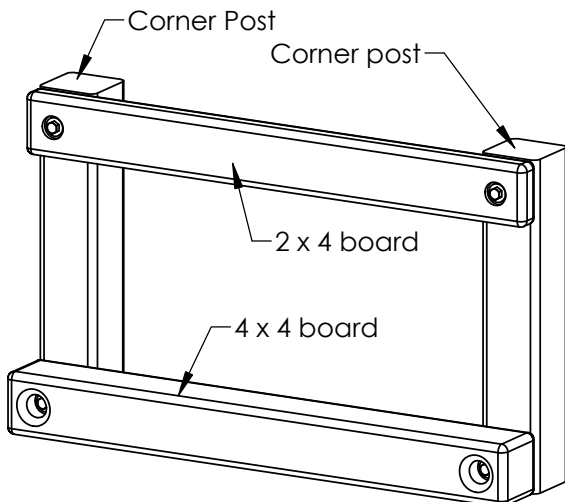
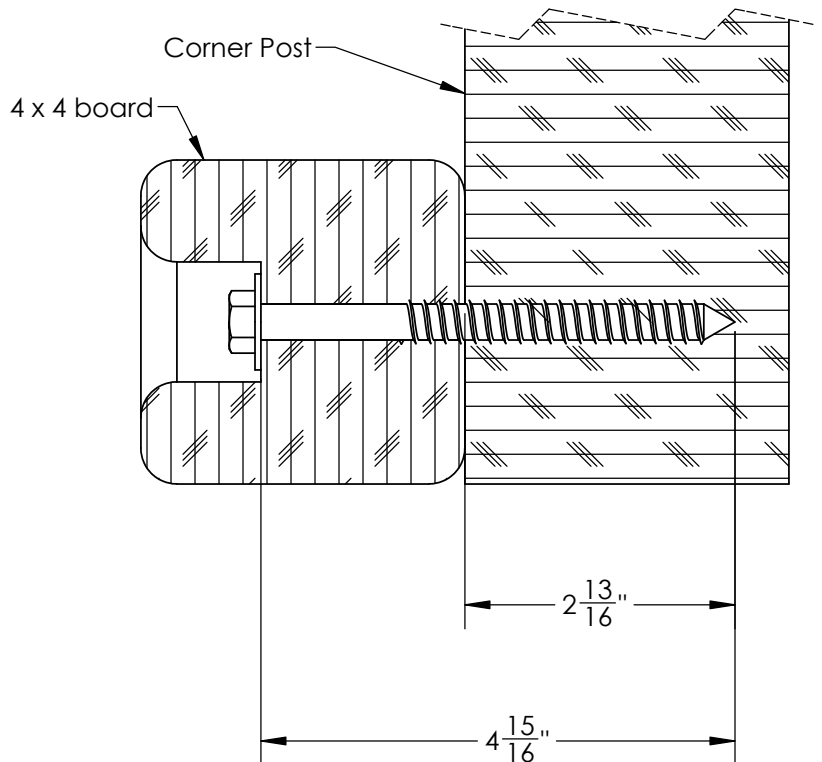

REQUIRED TOOL LIST:

- Standard or Cordless Drill
- #2 square bit
- Drill Bit 9/64"
- 1/2" Wrench and Socket
- Tape Measure
- Extension Cord (if using standard drill)
- Hammer
- Pencil

KIT CONTENTS**Swings, Slides, Accessories:**

NONE

Hardware:

see following pages

Wood Components:

see following pages

#8 X 1-1/4"
WOOD SCREW
QTY: 8



1509W HARDWARE

PAGE 1 OF 1

9/11/2014 JH

#8 X 1-1/2"
WOOD SCREW
QTY: 60



#8 X 2"
WOOD SCREW
QTY: 8



5/16" x 3-1/2"
HEX LAG
SCREW
QTY: 4

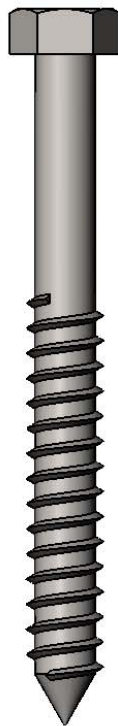

5/16" WASHER
QTY: 4

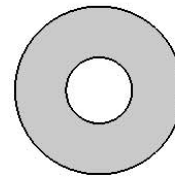

9

8

7

6

5







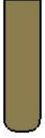
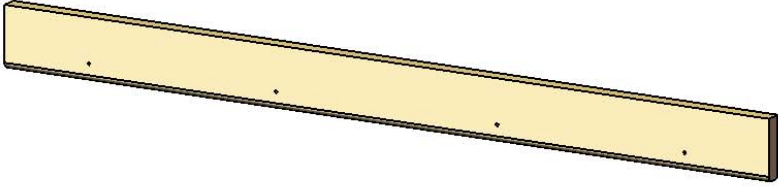

4

3

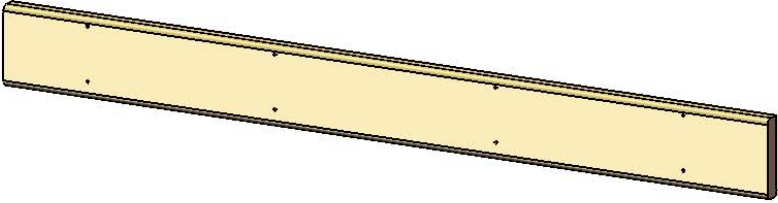
2

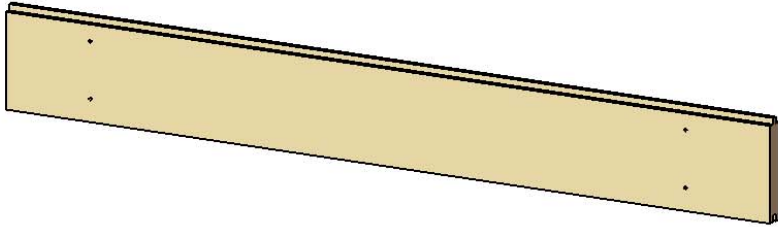
1

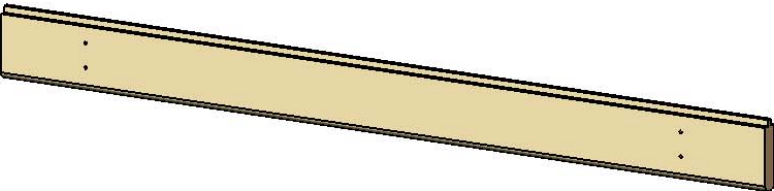
USE THE RULER TO THE RIGHT TO MEASURE YOUR BOLTS AND SCREWS. PICTURE VIEWS SHOWN ABOVE ARE 1:1 SCALE AND CAN BE USED TO MATCH BOLT AND SCREW SIZES.

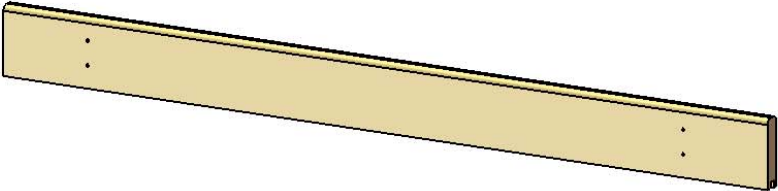
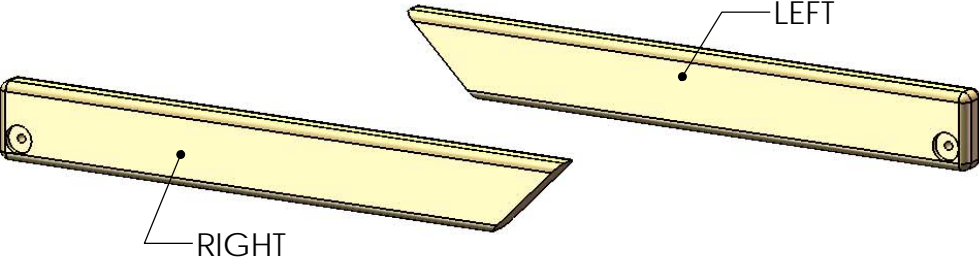
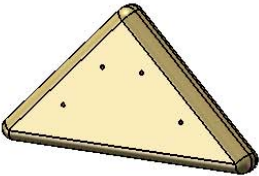
PICTURE	DESCRIPTION	QTY.
	 <p>1 X 3 X 36-3/4" ROOF PEAK BOARD 2 1-3-3675-RPB2</p>	1
	 <p>1 X 4 X 36-3/4" ROOF PEAK BOARD 1 1-4-3675-RPB1</p>	1
	 <p>1 X 5 X 36-3/4" ROOF BOARD 1-5-3675-RB</p>	10
	 <p>1 X 4 X 36-3/4" ROOF FINISHER 1-4-3675-RF</p>	2
	 <p>1 X 4 X 36-3/4" ROOF STARTER 1-4-3675-RS</p>	2
	<p>2 X 4 X 27" ROOF SUPPORT LEFT 2-4-2700-RSL RIGHT 2-4-2700-RSR</p>	2 2
	<p>5/4 X 6 X 10" ROOF PEAK SUPPORT 125-6-1000-RPS</p>	2

STEP 1: ROOF SUPPORT ASSEMBLIES

1: LOCATE FOUR 2 X 4 X 51-1/8" ROOF SUPPORT (LEFT), FOUR 2 X 4 X 51-1/8" ROOF SUPPORT (RIGHT) AND FOUR 5/4 X 6 X 10" ROOF PEAK SUPPORT PIECES.

2: FIND A FLAT SURFACE TO WORK ON. LAY THE ROOF SUPPORTS DOWN ON THE FLAT SURFACE WITH THE **COUNTERSUNK HOLES FACING DOWN**. ALIGN THE ANGLED ENDS OF THE ROOF SUPPORTS FLUSH WITH ONE ANOTHER. PLACE A ROOF PEAK SUPPORT ON TOP OF THE ROOF SUPPORTS AS SHOWN. THE EDGES SHOULD BE FLUSH WHERE SHOWN BELOW.

3: USE FOUR #8 X 2" WOOD SCREWS TO ATTACH THE ROOF PEAK SUPPORT TO THE ROOF SUPPORTS AS SHOWN BELOW.

4: MAKE ONE MORE ROOF SUPPORT ASSEMBLY BY REPEATING 2 AND 3.

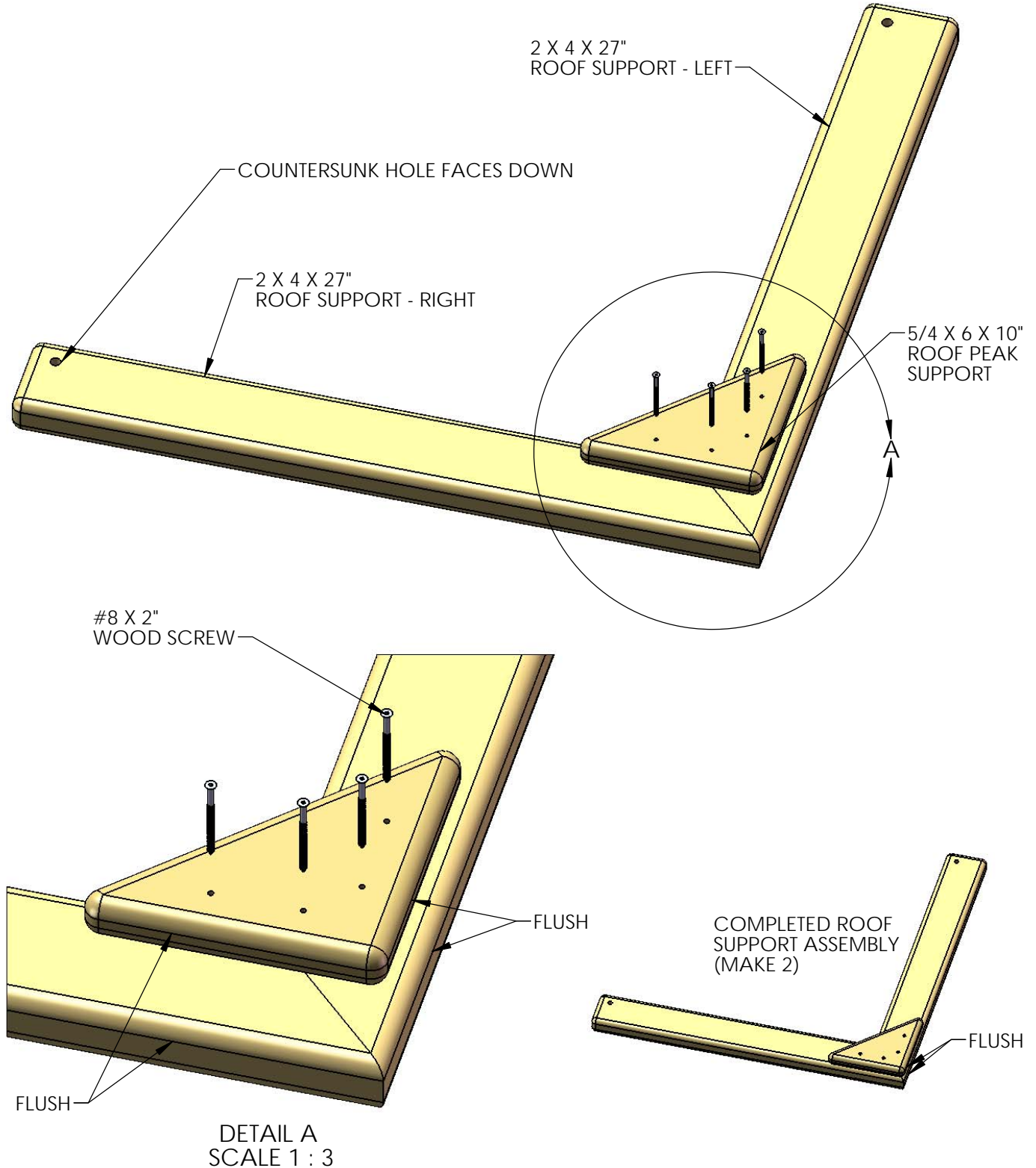

STEP 2: DRILLING CORNER POST HOLES

1: CHECK THE DIMENSION OF THE ROOF SUPPORT ASSEMBLIES AS SHOWN BELOW BEFORE DRILLING HOLES.

2: MEASURE AS SHOWN BELOW AND MAKE MARKS ON THE CORNER POSTS ON THE INSIDE.

3: DRILL A $\frac{9}{64}$ " HOLE BY 2-1/2" DEEP AT EACH MARK.

4: REPEAT SUBSTEPS 2-3 ON THE INSIDE OF THE OTHER POSTS AS POINTED OUT BELOW.

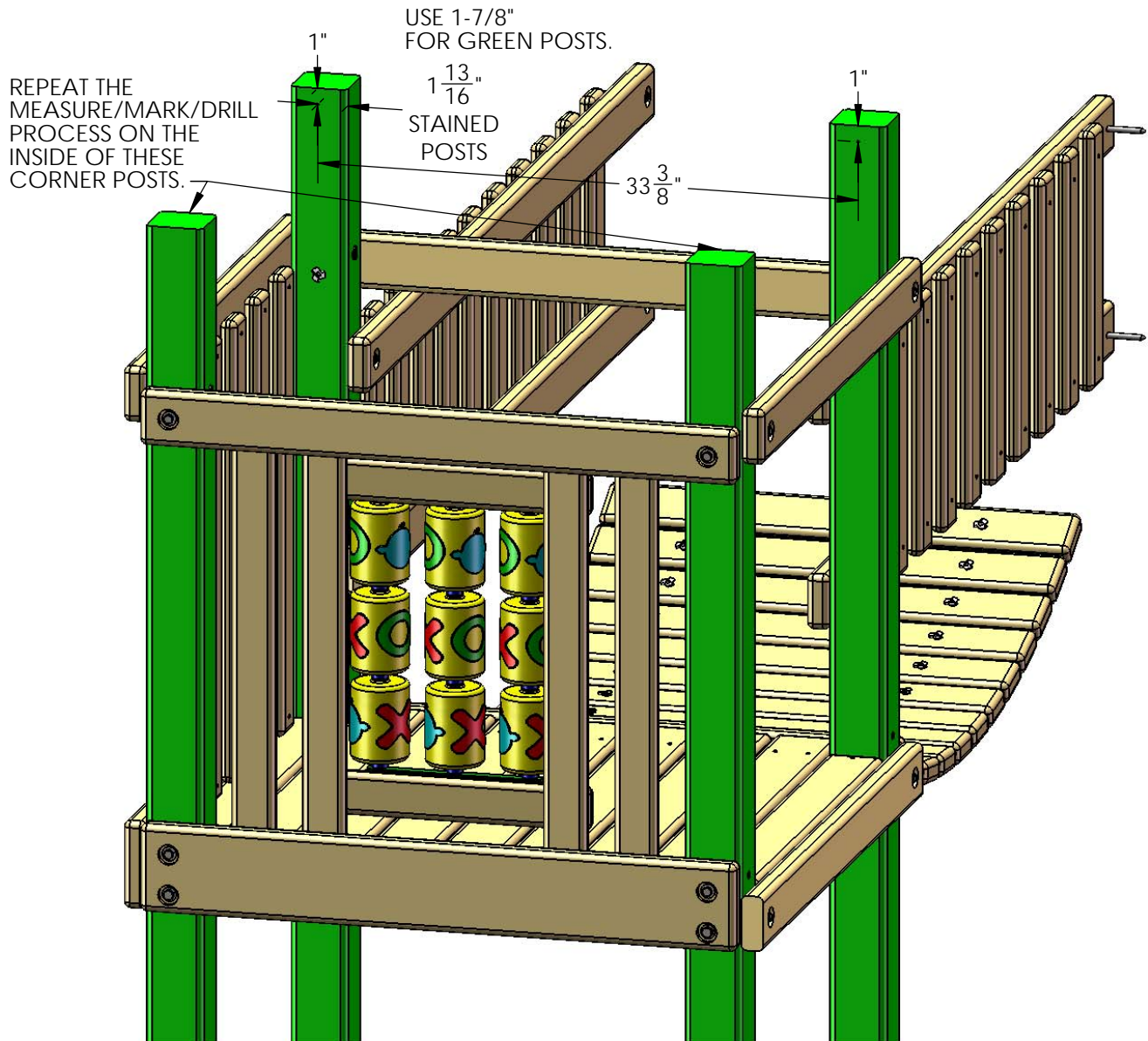
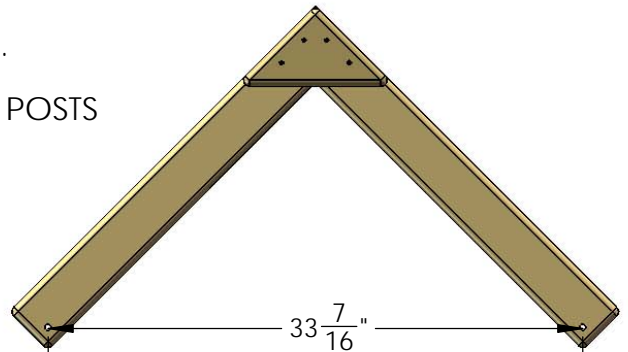

STEP 3: INSTALL ROOF SUPPORT ASSEMBLIES

- 1: PLACE TWO ROOF SUPPORT ASSEMBLIES ON THE CLATTER BRIDGE TOWER DECK.
- 2: THE (TRIANGLE) ROOF PEAK SUPPORT SHOULD FACE THE OUTSIDE.
- 3: ATTACH EACH ROOF SUPPORT ASSEMBLY TO THE HOLES DRILLED ON THE INSIDE OF THE CORNER POSTS WITH TWO 5/16" X 3-1/2" LAG SCREWS WITH TWO 5/16" WASHERS.

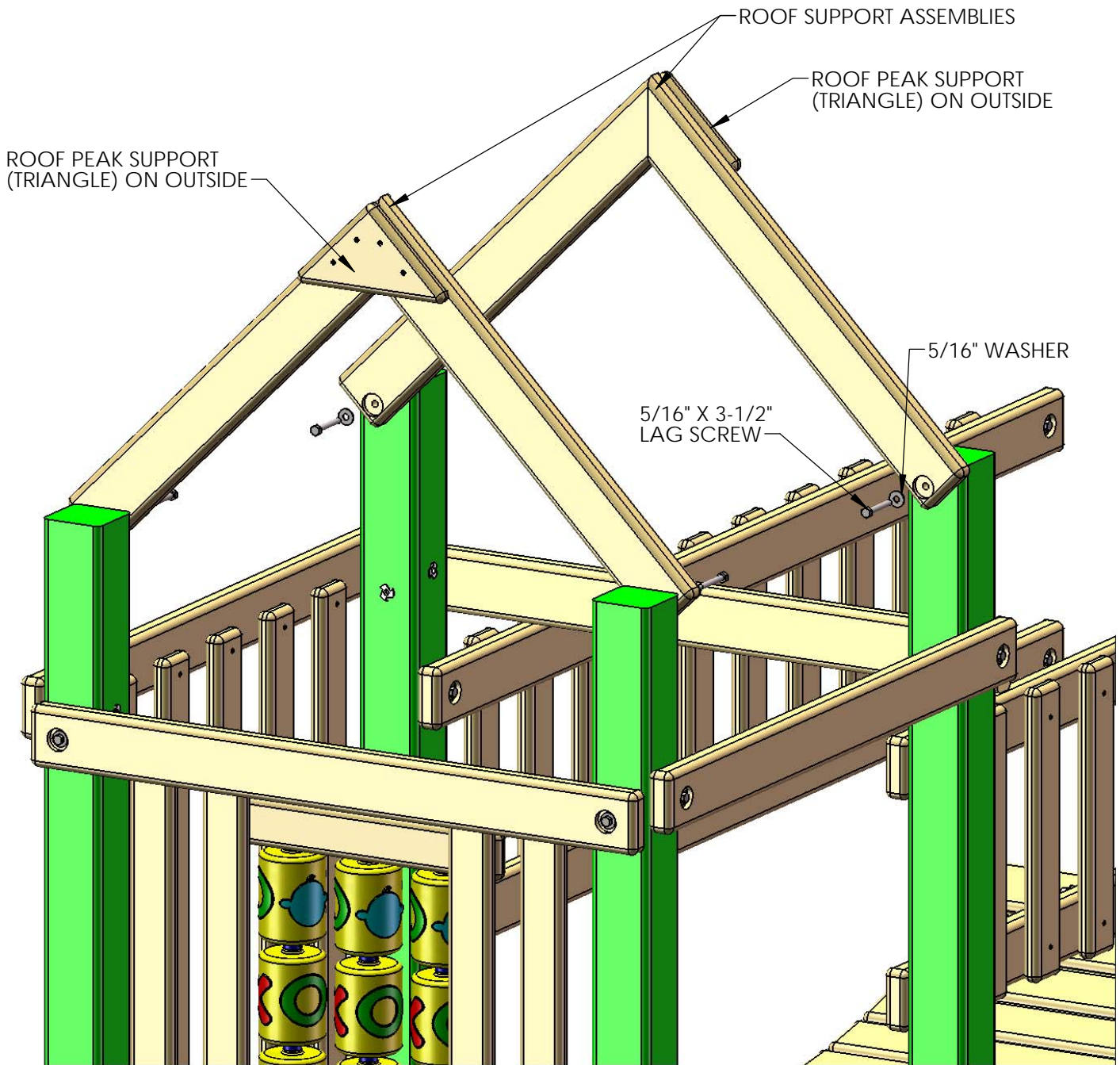

STEP 4: ROOF STARTERS

1: PLACE THE 1 X 4 X 36-3/4" GROOVE ONLY ROOF STARTERS AT THE PEAK OF THE ROOF. REFER TO THE DIAGRAM BELOW AND MAKE THE OVERHANG THE SAME ON EACH SIDE OF THE STARTER.

2: PLACE THE STARTERS AS CLOSE TO EACH OTHER AS POSSIBLE WITHOUT THEM OVERLAPPING.

3: FASTEN THE ROOF STARTER BOARDS TO THE ROOF SUPPORTS WITH 1-1/2" WOOD SCREWS.

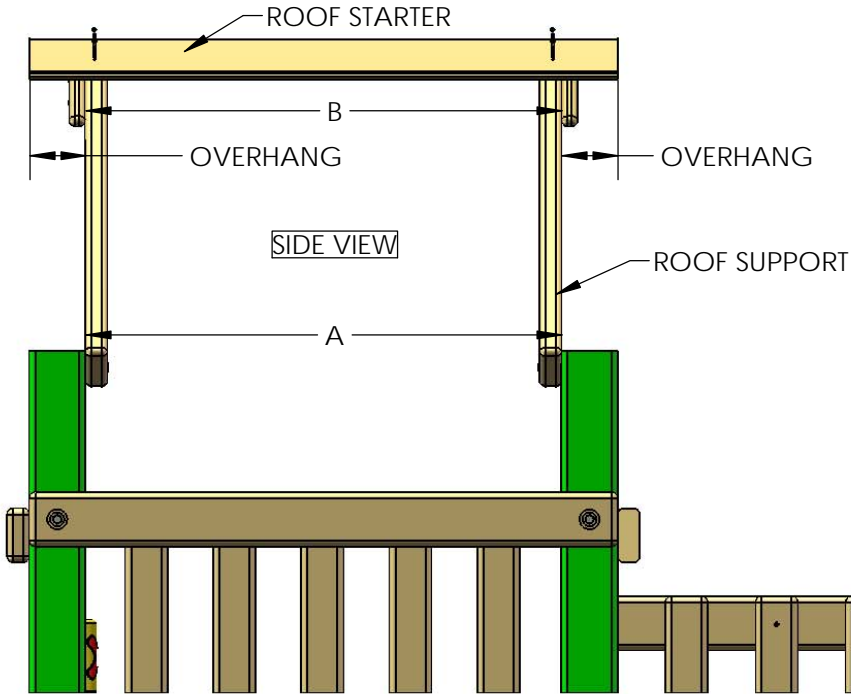

BEFORE INSTALLING THE ROOF STARTERS MAKE SURE DIMENSIONS A AND B MATCH. ALSO MAINTAIN THE SAME OVERHANG OF THE ROOF STARTERS ON EACH SIDE OF THE ROOF SUPPORTS.

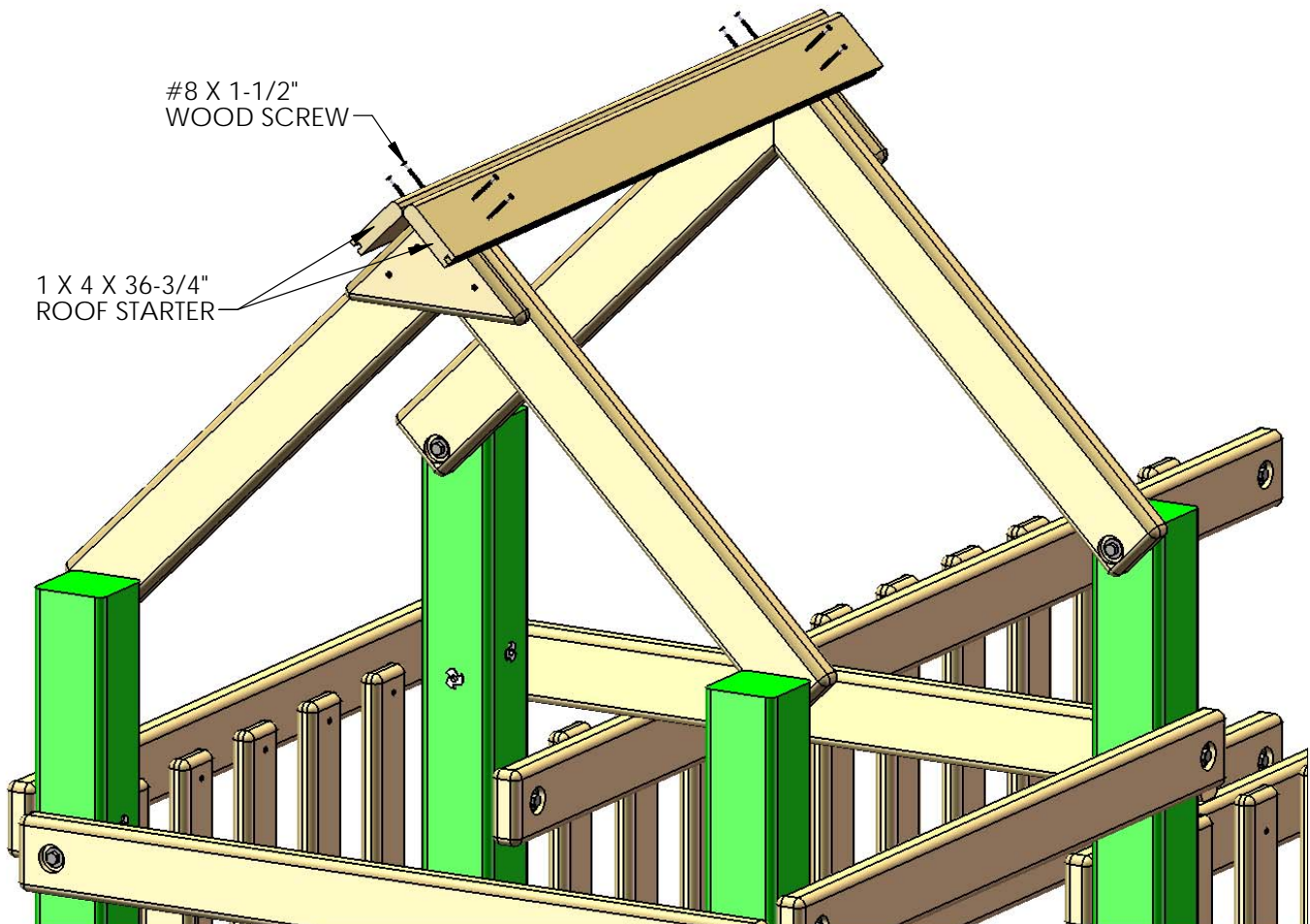

STEP 5: ROOF PEAK

1: FASTEN ROOF PEAK BOARD 1 TO ROOF PEAK BOARD 2 WITH FOUR #8 X 1-1/2" WOOD SCREWS TO MAKE A ROOF PEAK ASSEMBLY

2: PLACE THE ROOF PEAK ASSEMBLY ON TOP OF THE ROOF STARTERS. FASTEN THE ROOF PEAK ASSEMBLY TO THE ROOF STARTERS WITH EIGHT #8 X 1-1/4" WOOD SCREWS.

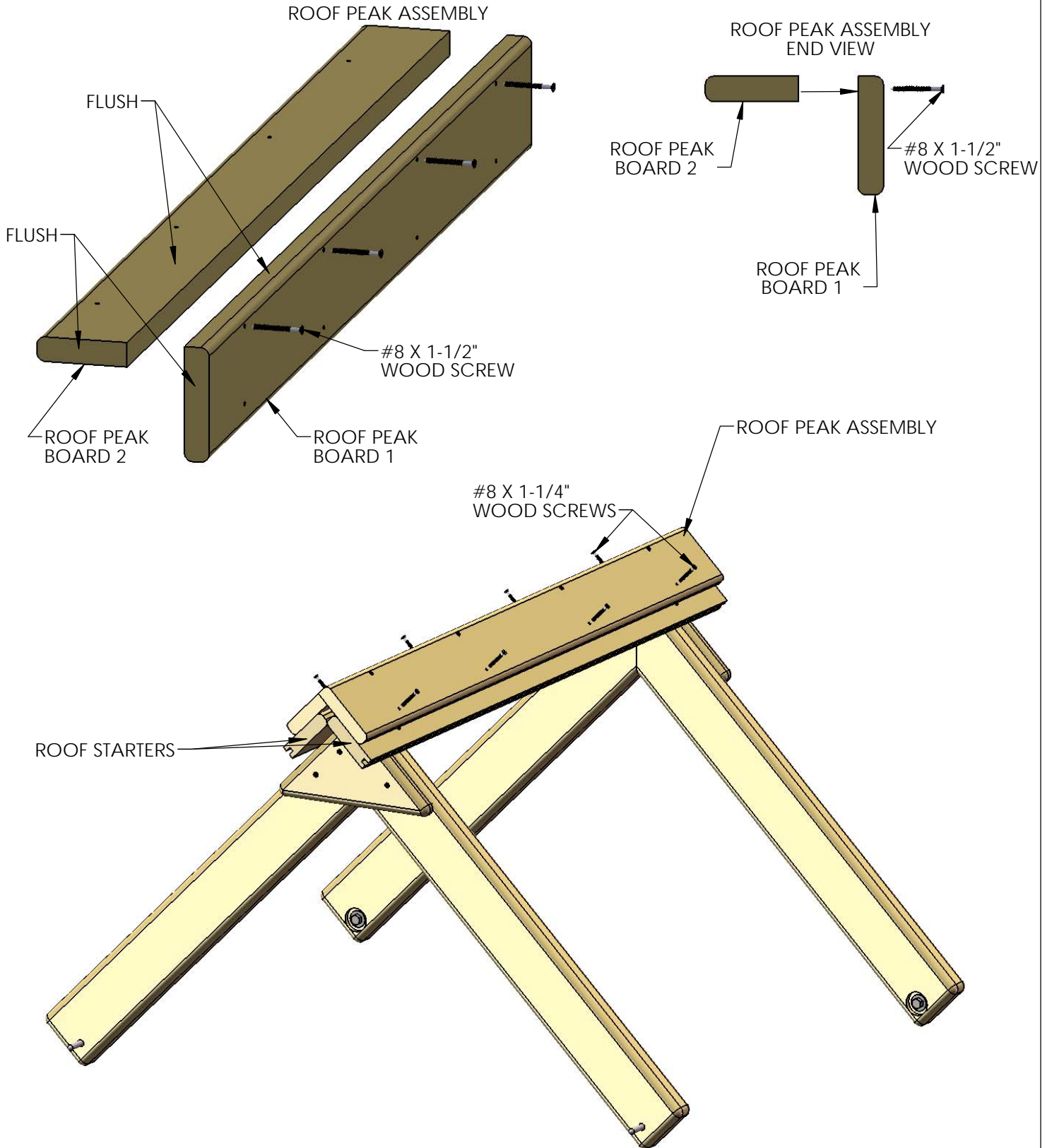

STEP 6: ROOF BOARDS AND ROOF FINISHERS

1: LOCATE TEN 1 X 5 X 36-3/4" ROOF BOARDS. SLIDE THE TONGUE OF THE ROOF BOARD INTO THE GROOVE OF THE ROOF STARTER. SECURE THE ROOF BOARD TO THE ROOF SUPPORTS WITH FOUR #8 X 1-1/2" WOOD SCREWS.

2: SLIDE THE NEXT ROOF BOARD TONGUE INTO THE GROOVE OF THE PREVIOUS ROOF BOARD. SECURE THE ROOF BOARD TO THE ROOF SUPPORTS WITH FOUR #8 X 1-1/2" WOOD SCREWS.

3: REPEAT SUBSTEP 2 FOR THE NEXT 3 ROOF BOARDS.

4: LOCATE A 1 X 4 X 36-3/4" ROOF FINISHER (TONGUE ONLY). INSERT THE TONGUE OF THE ROOF FINISHER INTO THE GROOVE OF THE LAST ROOF BOARD. SECURE THE ROOF FINISHER TO THE ROOF SUPPORTS WITH FOUR #8 X 1-1/2" WOOD SCREWS.

5: REPEAT SUBSTEPS 1 THROUGH 4 FOR THE ROOF BOARDS AND ROOF FINISHER ON THE OTHER SIDE OF THE ROOF.

