



Model # DC-3345

DATE STAMP

CALL US FIRST
1-877-PREPAC1
1-877-773-7221



Mon - Fri 7am - 4pm PST
10am - 7pm EST

- For help with assembly
- If you have received a damaged or defective part or are missing hardware.

We will process replacement parts in 2 business days or less. Parts are shipped via UPS Ground or mail.

Before you call please:

- 1) Record the following information from the shipping label on the outside of the box. You will need it for warranty purposes:
 - Ship To Name
 - Sales Order Number
- 2) Note the product model number.
- 3) Review the contents of your shipment to determine what you are missing. This unit is shipped in 2 cartons. Make sure you have received both.

Online Option:

Fill out the Replacement Parts Order form in the Product Support section of our website: www.prepacmfg.com

5-Drawer Chest Assembly Instructions

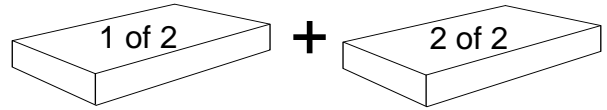

This product is shipped in
2 cartons



Make sure you have both cartons. Sometimes cartons shipped on the same day get separated and are delivered on different days.

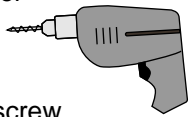

Depending on collection, the style of your product may vary from this picture.

Required Tools	Optional Tools
<p>Screwdrivers</p>  <p>Phillips Head</p>  <p>Flat Head</p>  <p>Hammer</p>	<p>Using a power screwdriver will speed up assembly.</p>  <p>Caution Do not over tighten any screw. The last few turns of each screw should be done very slowly or by hand.</p>

Prepac Manufacturing Ltd.
6705 Dennett Place
Delta, BC V4G 1N4

LB-0594-R
2012-06-15

Hardware Identification

Cabinet Hardware

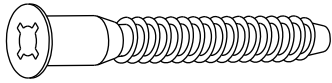

2" Confirmat Screws
(12)
RM-0001



Screw Cover Caps
(12)
RM-0226 black
RM-0620 cherry
RM-0304 espresso
RM-0523 maple
RM-0008 white



15mm Zinc Cam
(4)
RM-0103

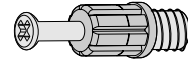

Green Twister Dowel
(4)
RM-0501

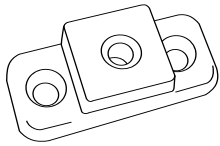

T Spacer
(20)
RM-0628



Drawer Slide Screw
(60)
RM-0074

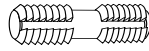

Plastic Dowels
(11)
RM-0072



3/4" Nail
(30)*
RM-0022
**More than required*

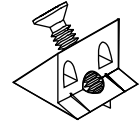

Drawer Bottom Stabilizer
(5)
RM-0839

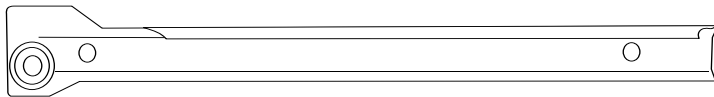

LEFT Cabinet Slide (5)

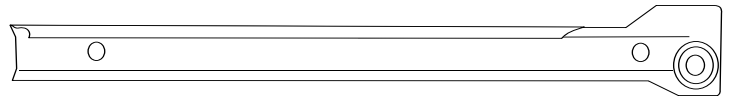

RIGHT Cabinet Slide (5)

Drawer Hardware

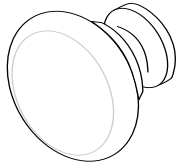

Knob (10)
RM-0464 maple / black
RM-0625 white / cherry
RM-0464E espresso



#8 7/8" Machine Screw
(10)
RM-0465



1 LEFT Drawer Slide per Drawer (Total = 5)



1 RIGHT Drawer Slide per Drawer (Total = 5)

Set of Grey Drawer & Cabinet Slides (5 Sets)
RM-0469-G

4 per drawer



#8 - 1 1/2" Hi Lo Screws
(20)
RM-0504



12mm Zinc Cam
(20)
RM-0715

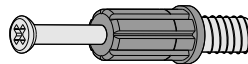

Black Twister Dowel
(20)
RM-0500

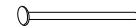

3/4" Nail
(20)
RM-0022



Drawer Slide Screw
(20)
RM-0074

Cable Tie Hardware Package

HP-0608

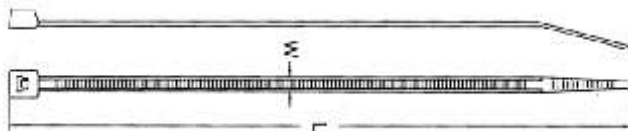

Cable Tie (1)
Attache pour câble
RM-0459



Mounting Base (2)
Base de support
RM-0458

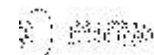

#6-3/4" Pan Head
Screw (1)
Vis #6-3/4 po.
RM-0460

Cabinet Parts

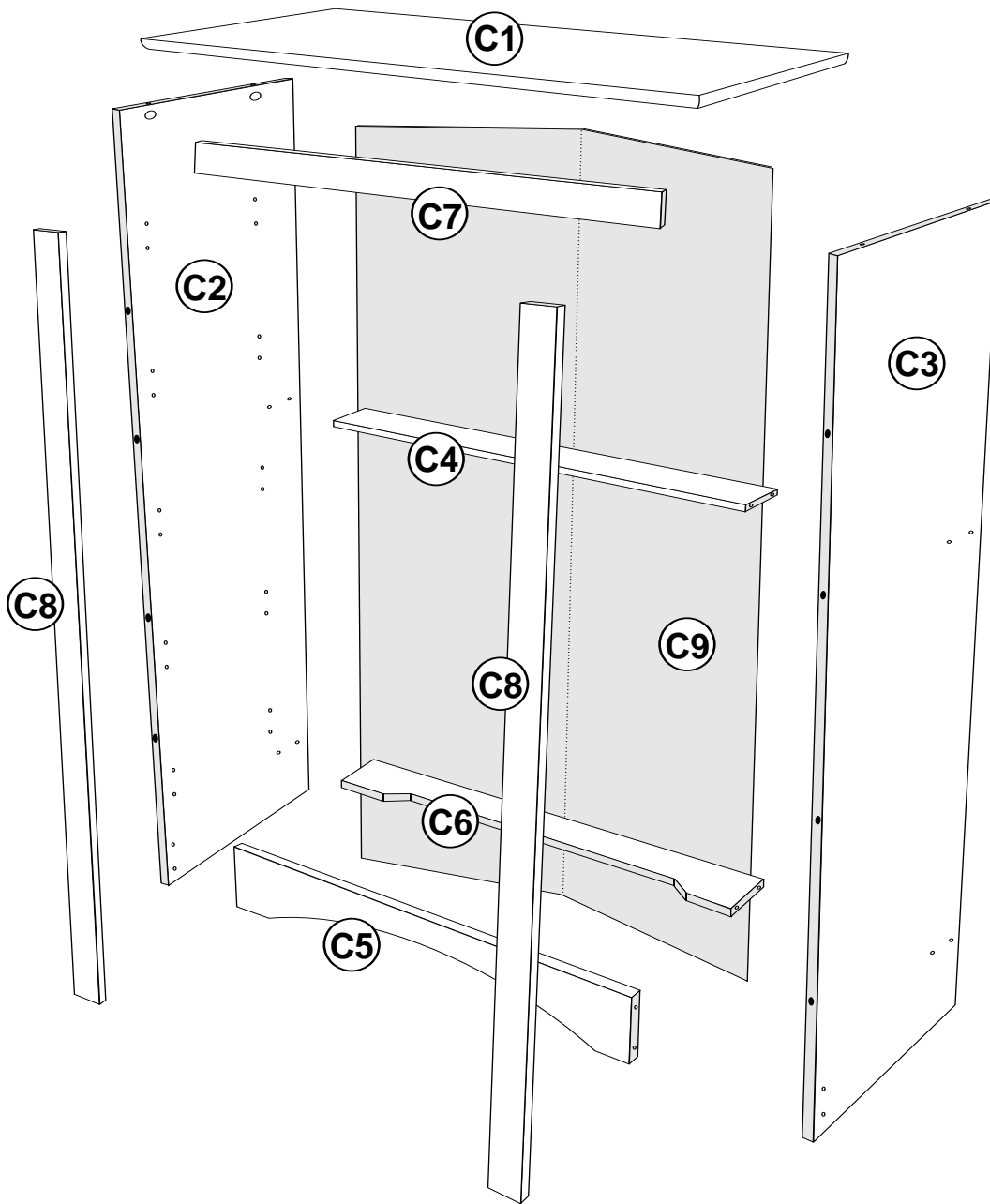

C1

Profiled Top (1)
TP-0412 black
TP-0492 cherry
TP-4630 espresso
TP-0472 maple
TP-0402 white

C2

Left Side (1)
SL-0412 black
SL-0492 cherry
SL-4611 espresso
SL-0472 maple
SL-0402 white

C3

Right Side (1)
SR-0412 black
SR-0492 cherry
SR-4611 espresso
SR-0472 maple
SR-0402 white

C4

Plain Stabilizer (1)
ST-4112 black
ST-4912 cherry
ST-4631 espresso
ST-4712 maple
ST-4012 white

C5

Decorative Stabilizer A (1)
KR-0412 black
KR-0492 cherry
KR-0462 espresso
KR-0472 maple
KR-0402 white

C6

Decorative Stabilizer B (1)
ST-4111 black
ST-4911 cherry
ST-4630 espresso
ST-4711 maple
ST-4011 white

C7

1 $\frac{3}{4}$ " Top Molding (1)
TR-4112 black
TR-4912 cherry
TR-4612 espresso
TR-4712 maple
TR-4012 white

C8

1 $\frac{3}{4}$ " Side Molding (2)
TR-0414 black
TR-0494 cherry
TR-0464 espresso
TR-0474 maple
TR-0404 white

C9

Foldable Backer (1)
BB-0106

STEP 1 Estimated Time: 15 - 25 minutes

1a Attach T-spacers to left and right cabinet sides using drawer slide screws

1b Then, attach metal cabinet slides to T-spacers using drawer slide screws

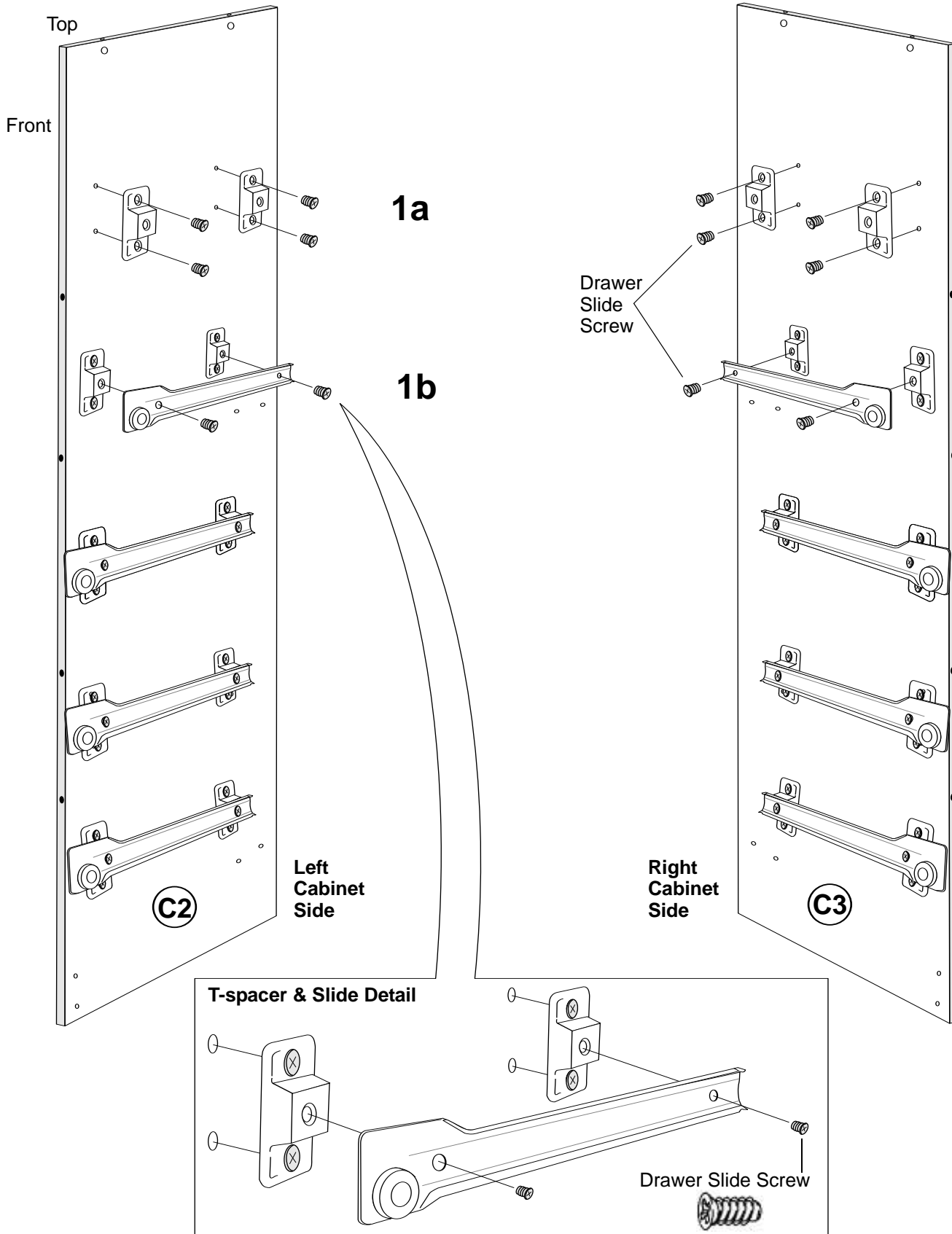

STEP 2 Estimated Time: 1 minute

Insert cams into holes on the top of each side.

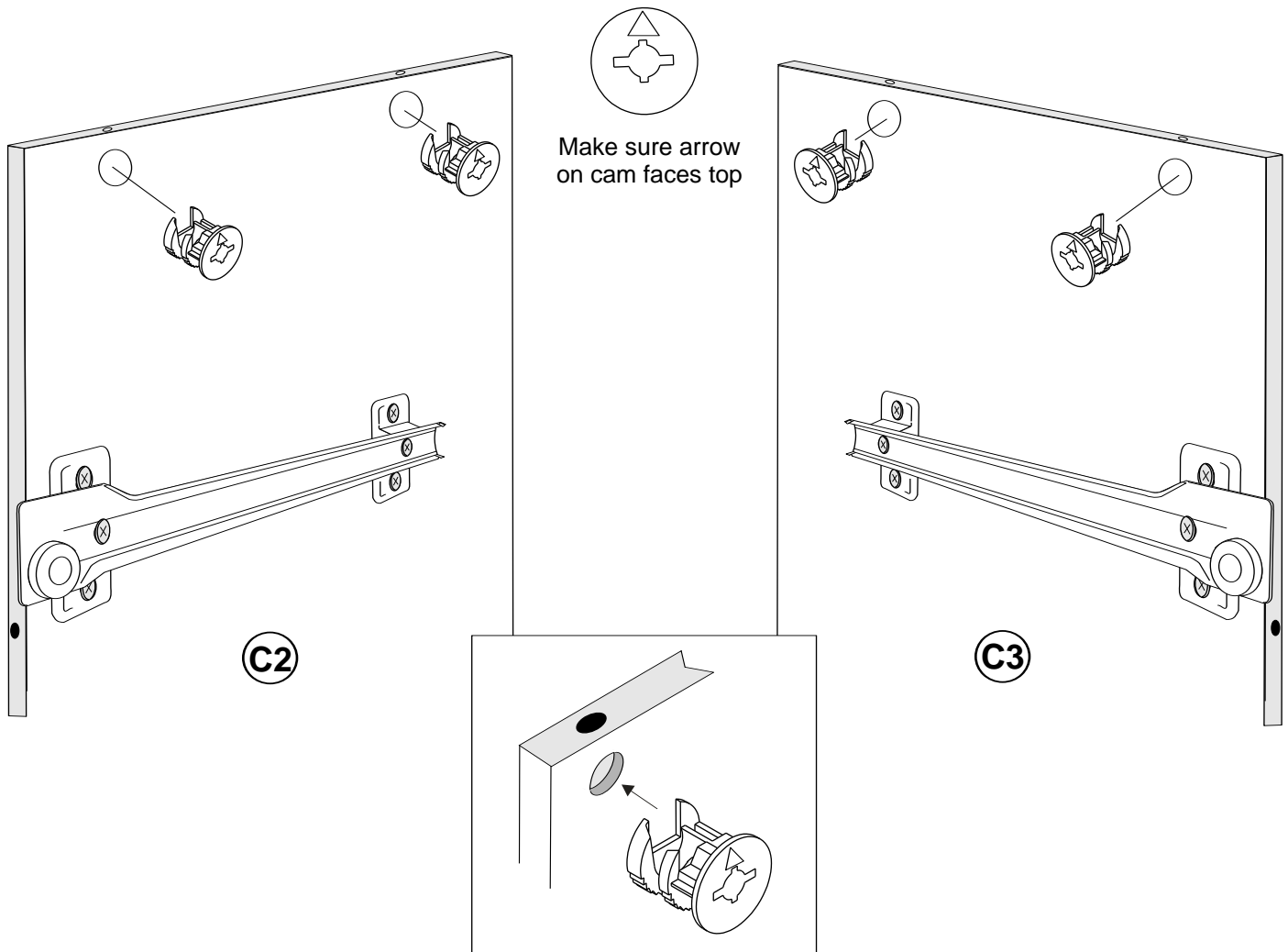

STEP 3 Estimated Time: 2 minutes

Screw **green** twister dowels into the underside of the top

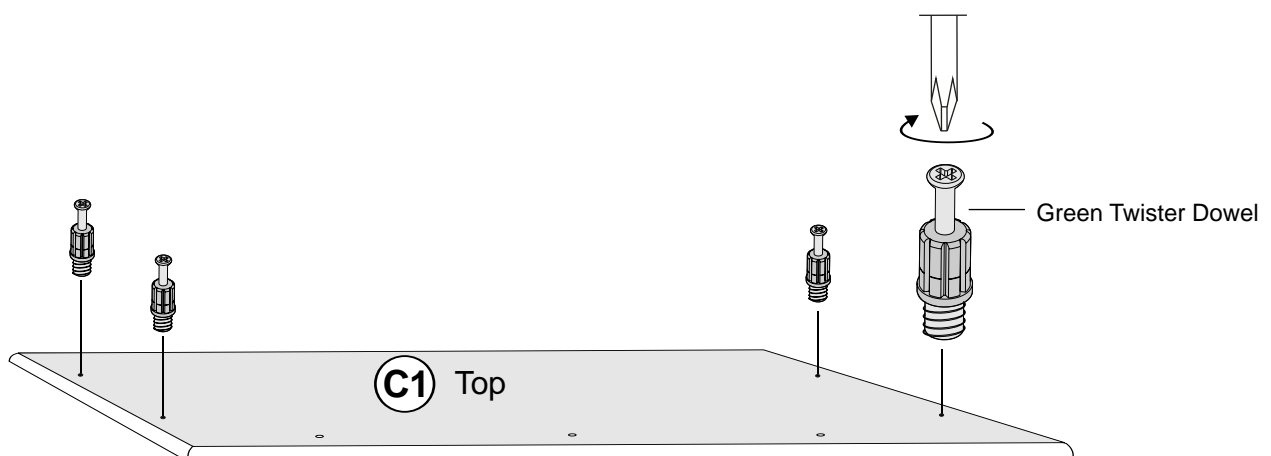

STEP 4 Estimated Time: 10 minutes

Attach all 3 stabilizers to left and right sides using Confirmat screws. Insert screw cover caps to finish.

Decorative stabilizers **C5** & **C6** are interchangeable. Please choose the style that you prefer and attach it to the front.

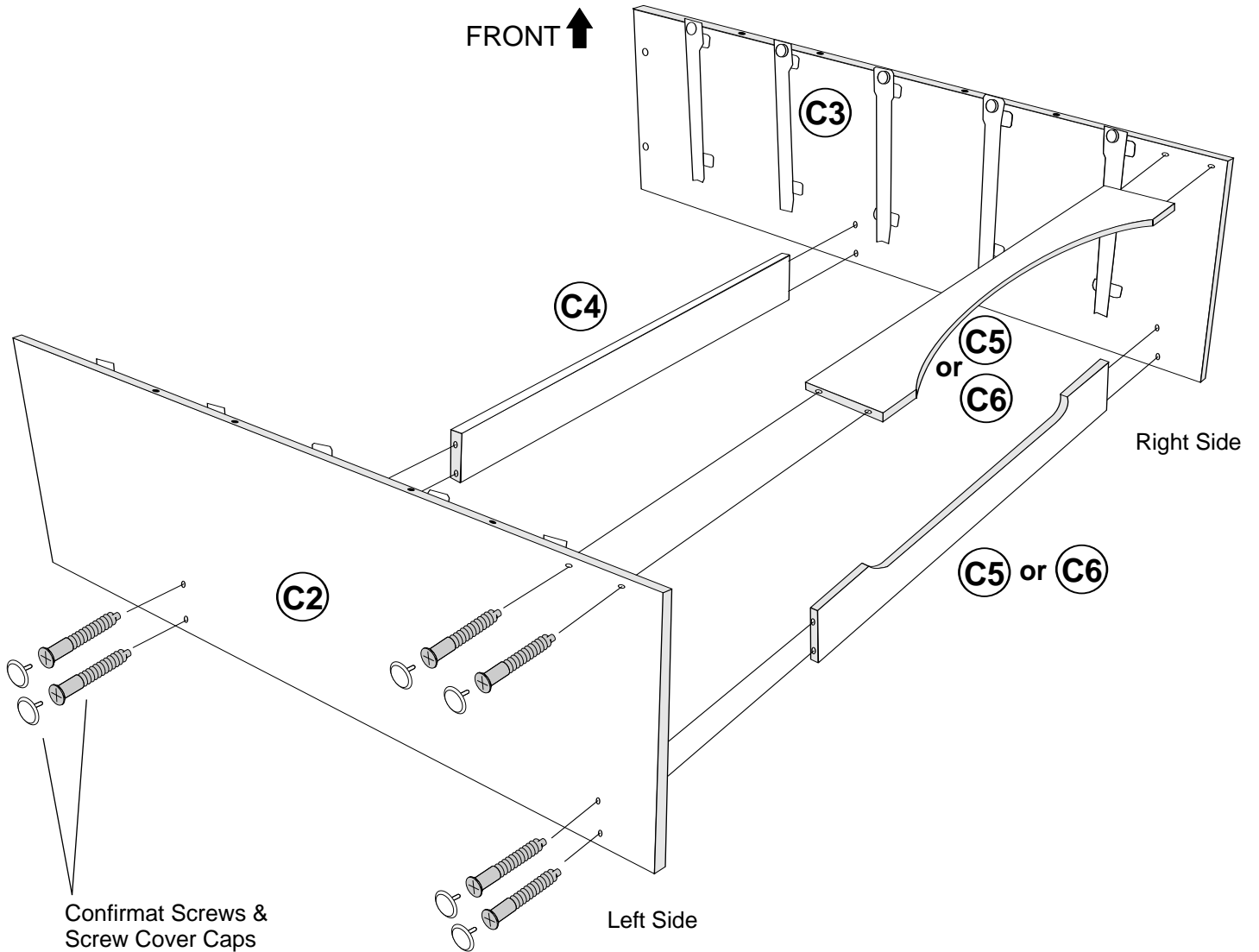

STEP 5 Estimated Time: 2 minutes

Attach top to sides and lock cams using a flat head screwdriver

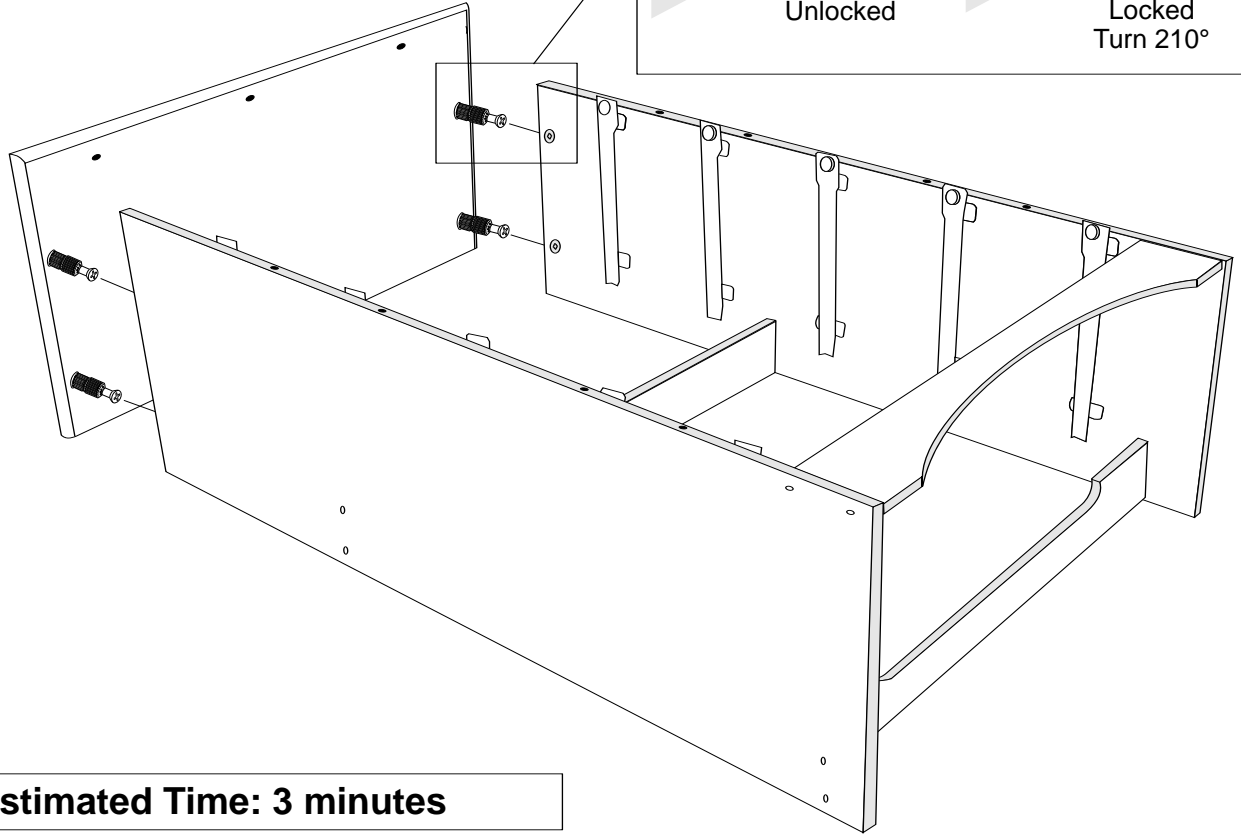
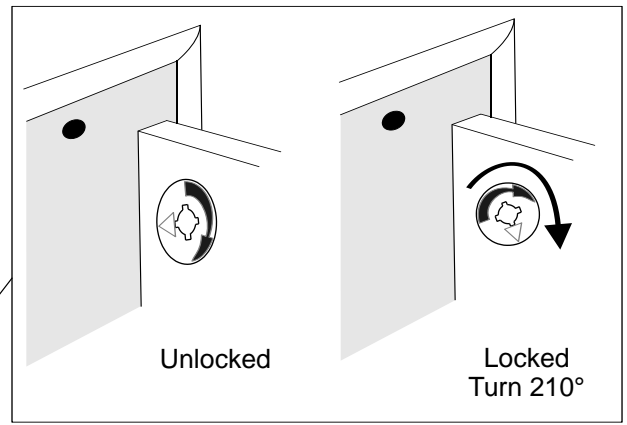
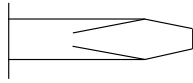

STEP 6 Estimated Time: 3 minutes

Hammer plastic dowels halfway into side and top moldings

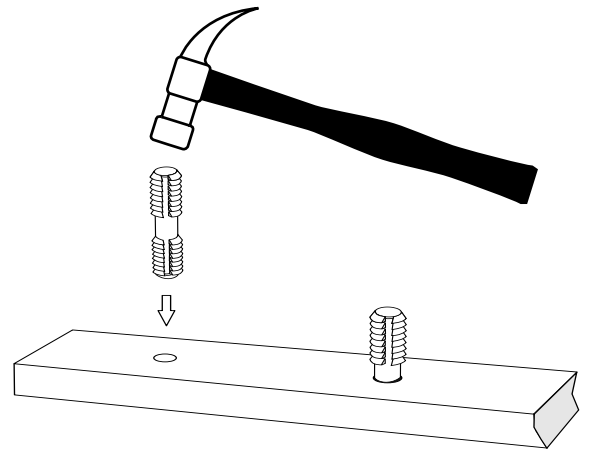
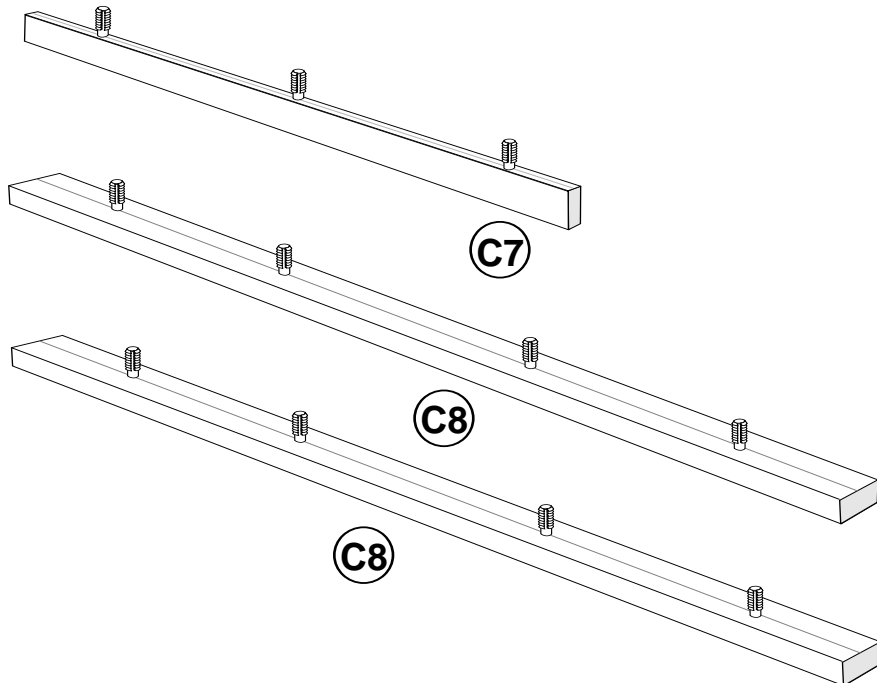

STEP 7 Estimated Time: 3 minutes

Attach top & side moldings.

Using your hands, apply even pressure to moldings and press firmly

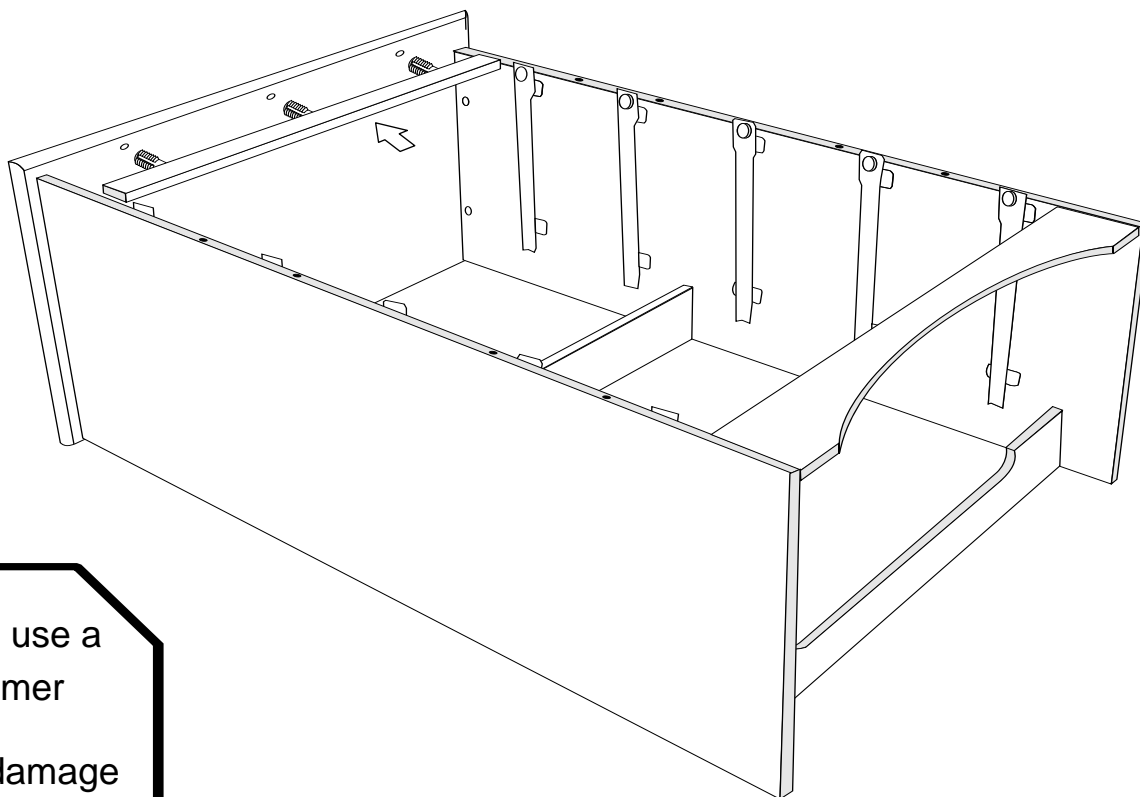

Do not use a
hammer
It may damage
the molding

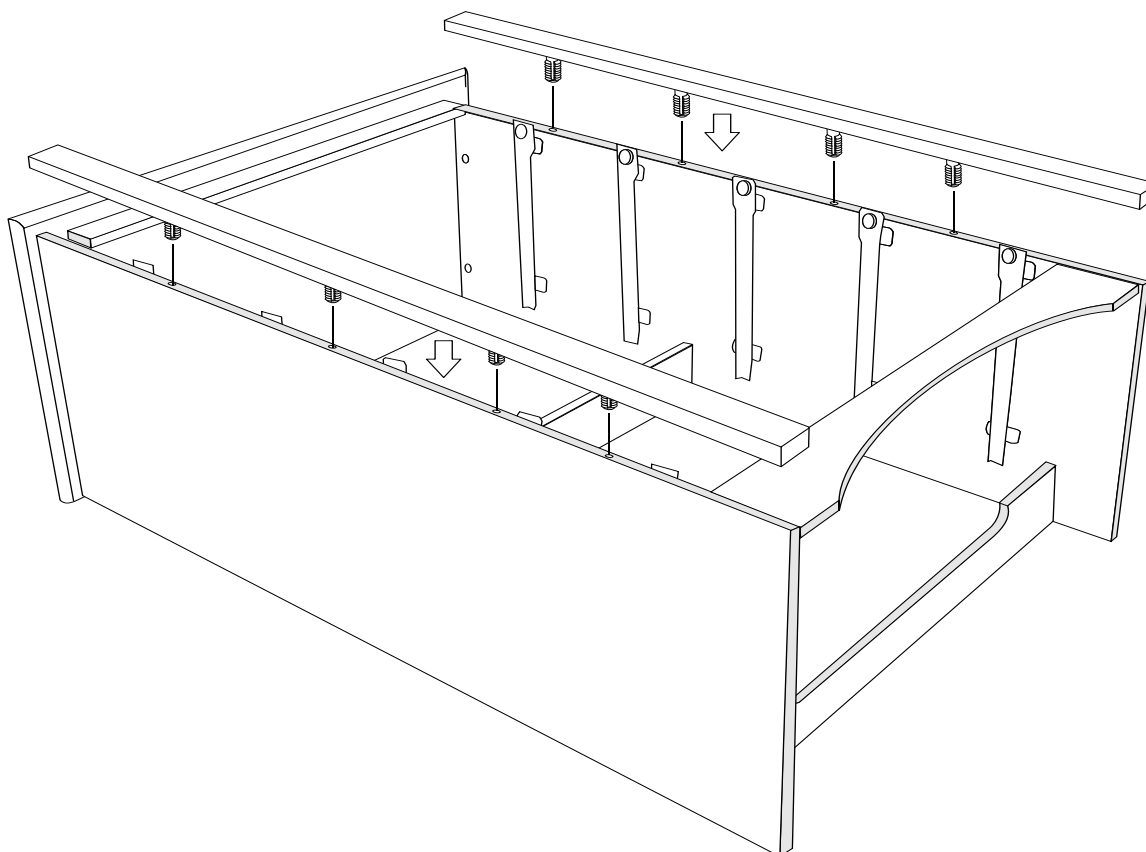

STEP 8 Estimated Time: 4 minutes

Carefully turn chest over and attach backer

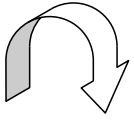

Nail backer as indicated. You may have more nails than are necessary



NOTE:
Do not stand
product up without
the backer
fastened

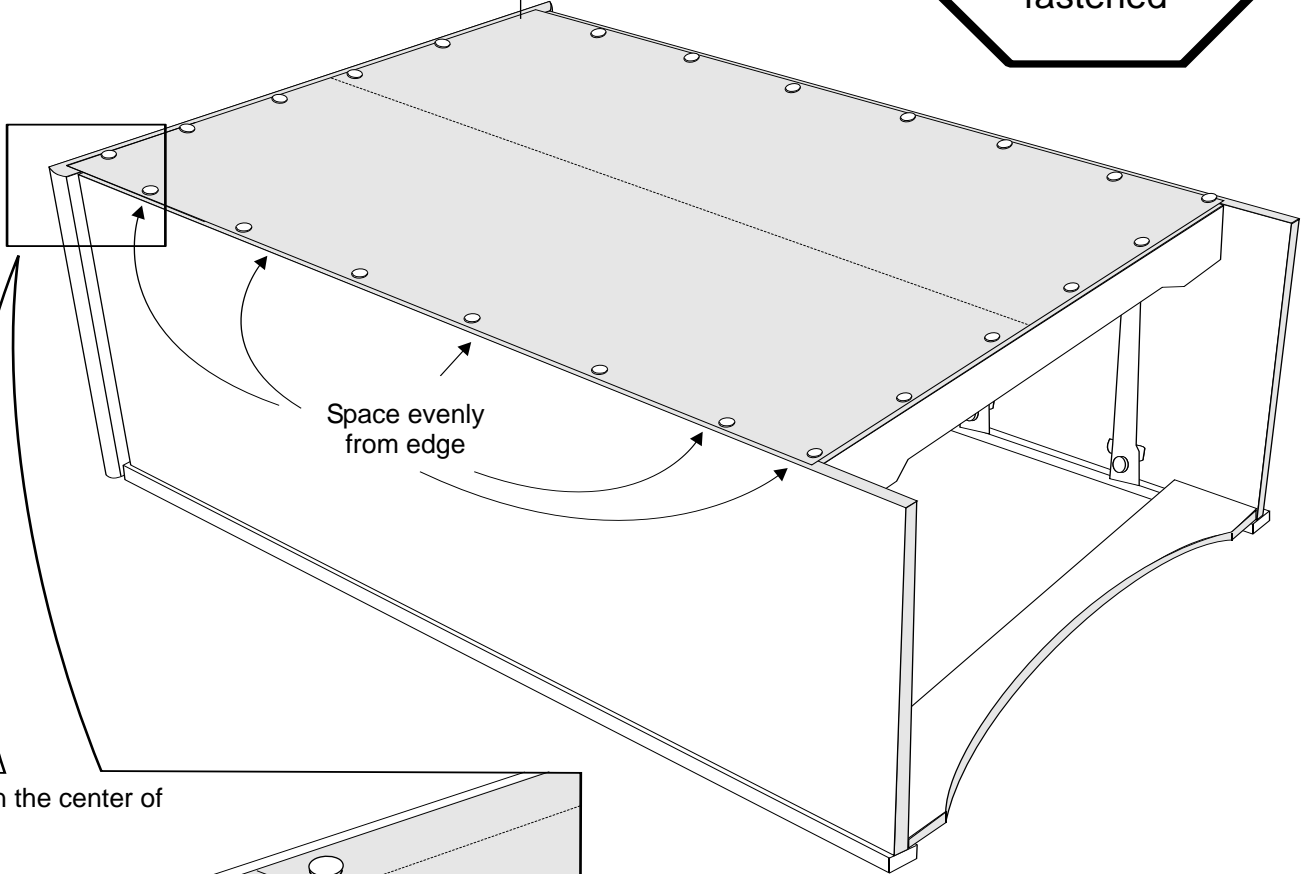

Position nails in the center of the board

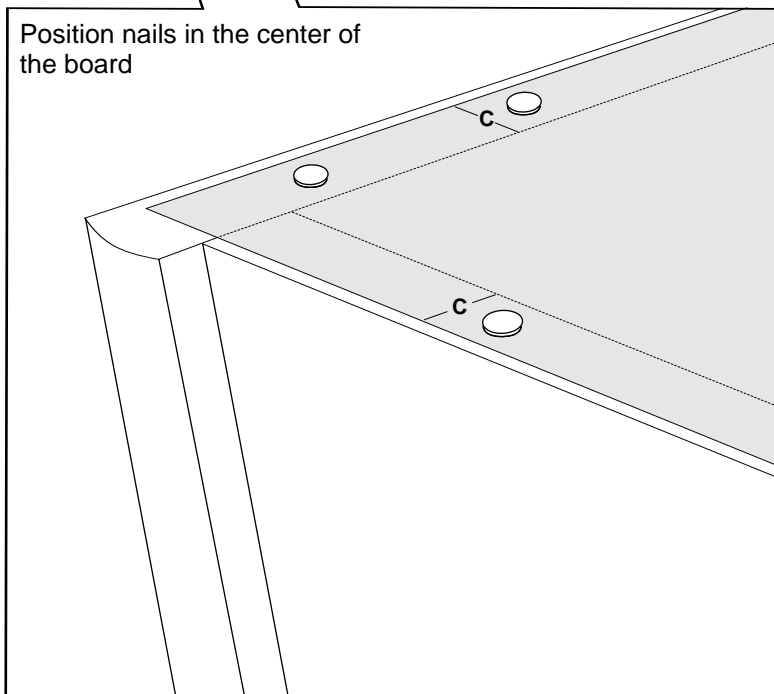

Drawer Parts Identification

D1
 Drawer Front (5)
DF-10014-B black
DF-10017-C cherry
DF-10014-E espresso
DF-10014-M maple
DF-10017-W white

D2
 Left Drawer Side (5)
DS-0412W-L

D4
 Drawer Back (5)
DK-0415W

D3
 Right Drawer Side (5)
DS-0412W-R

D5
 Drawer Bottom (5)
DB-0415
 unfinished

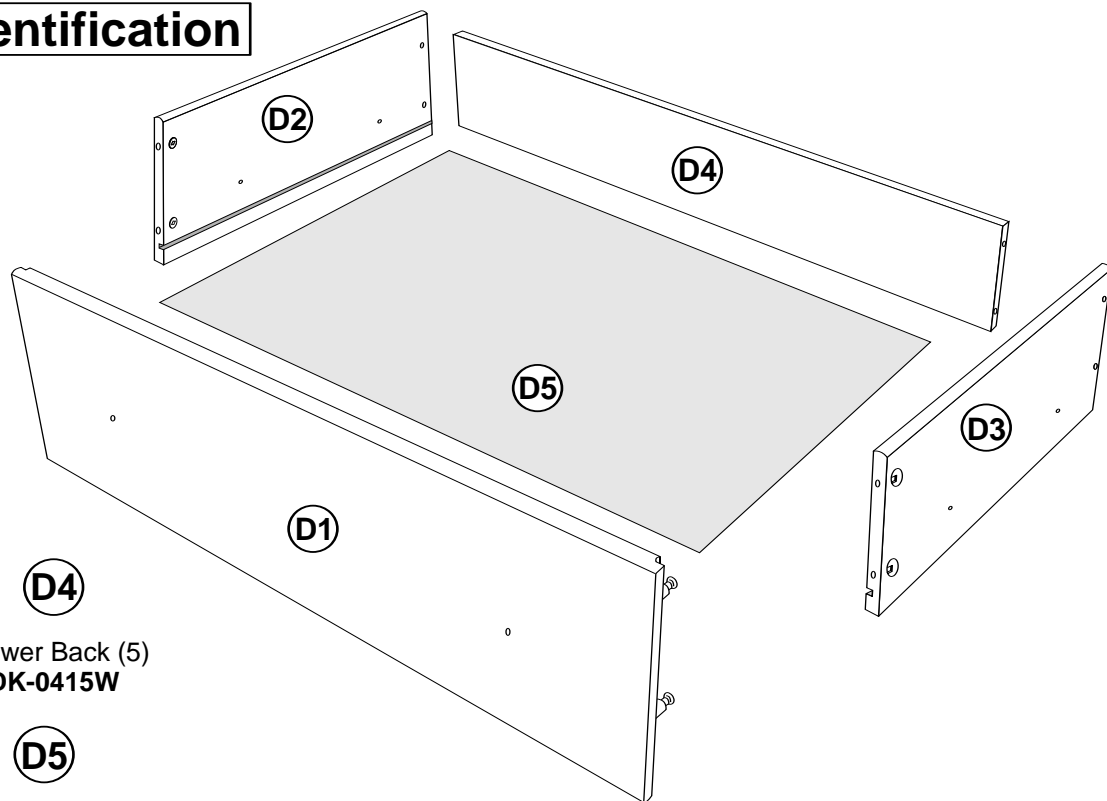

STEP 9 Estimated Time: 5 minutes PER DRAWER

9a Insert cams into drawer sides

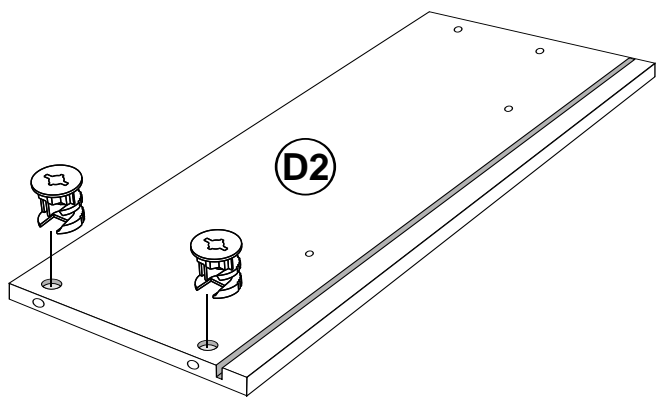

Left Drawer Side

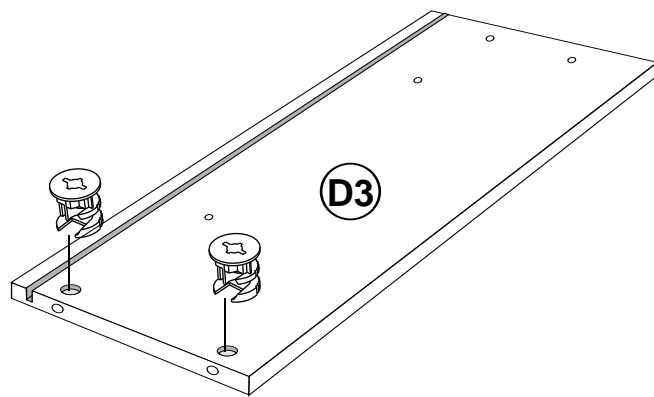

Right Drawer Side

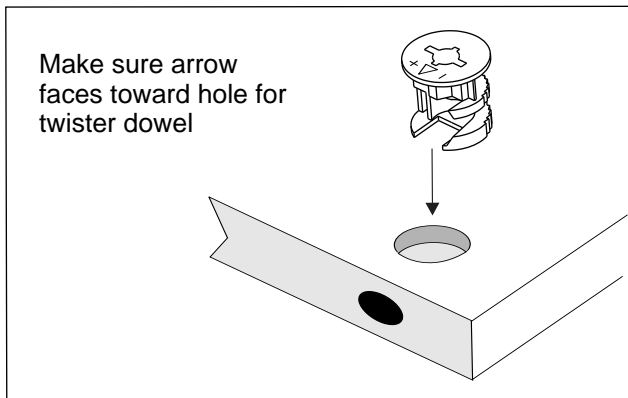

9b Screw **black** twister dowels into drawer fronts

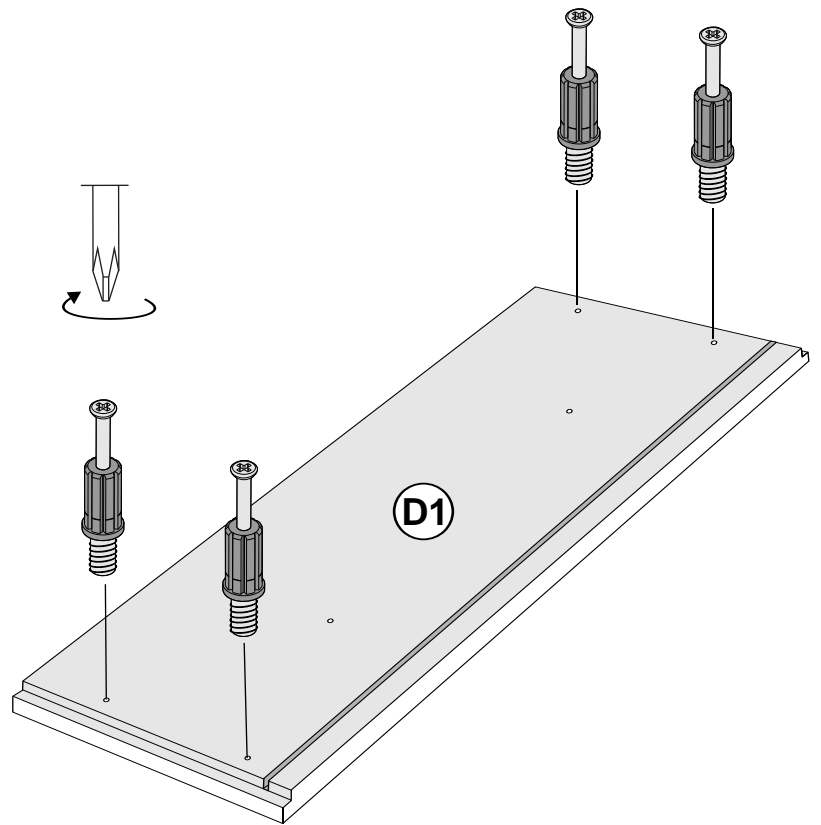

9c Attach drawer sides to drawer back with 1½" Hi Lo screws

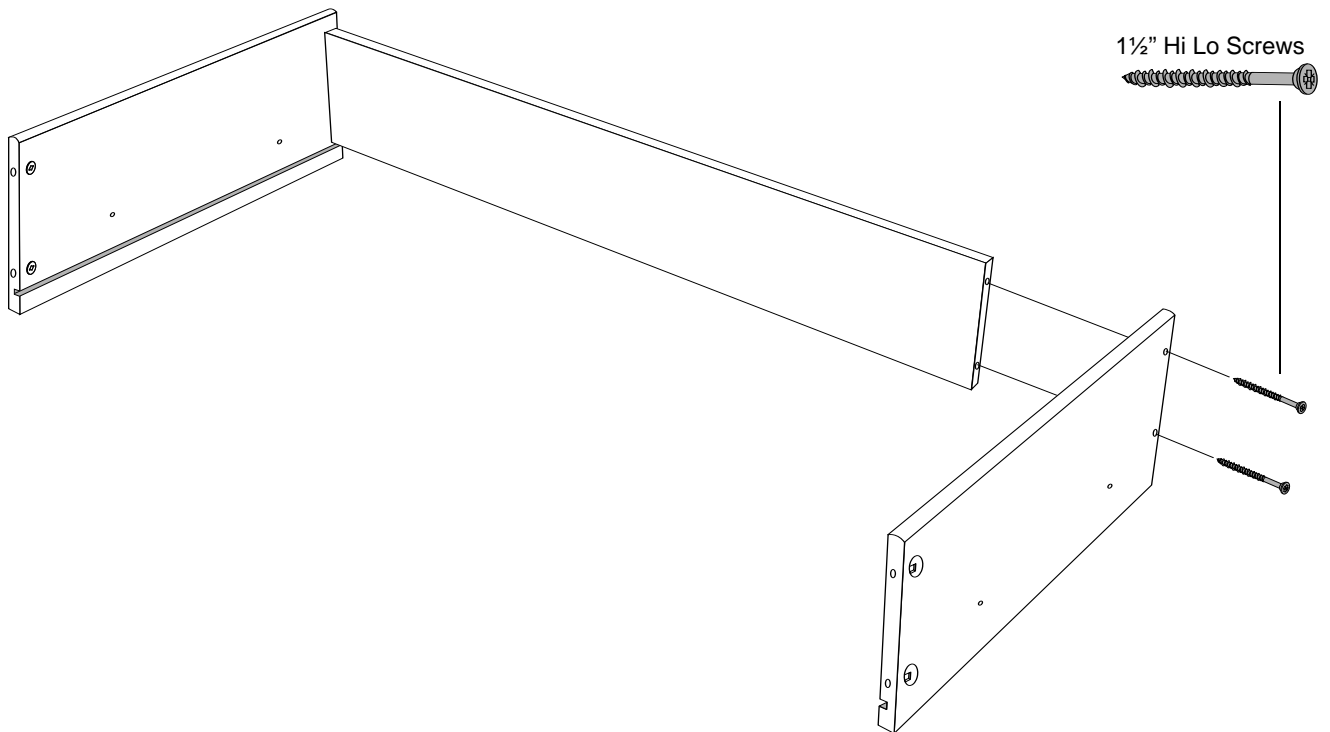

9d

Attach drawer front and tighten cams using a flat head screwdriver

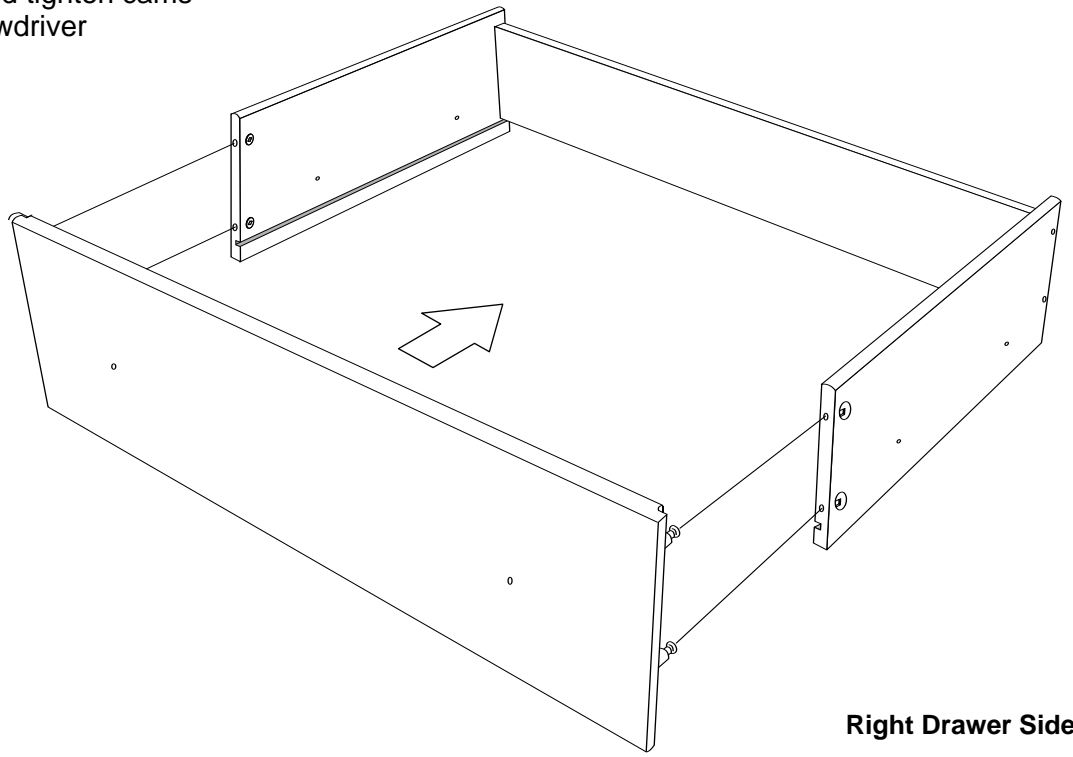
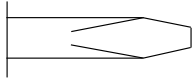

Left Drawer Side

Right Drawer Side

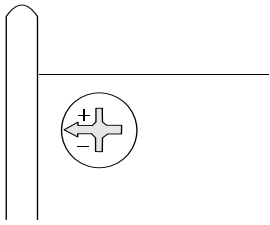

Unlocked

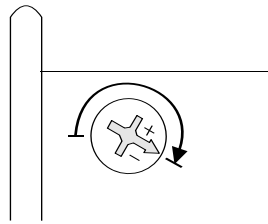

Locked
Turn 210°

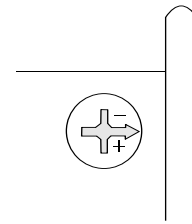

Unlocked

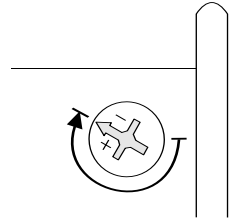

Locked
Turn 210°

9e

Turn drawer upside down and slide drawer bottom into grooves

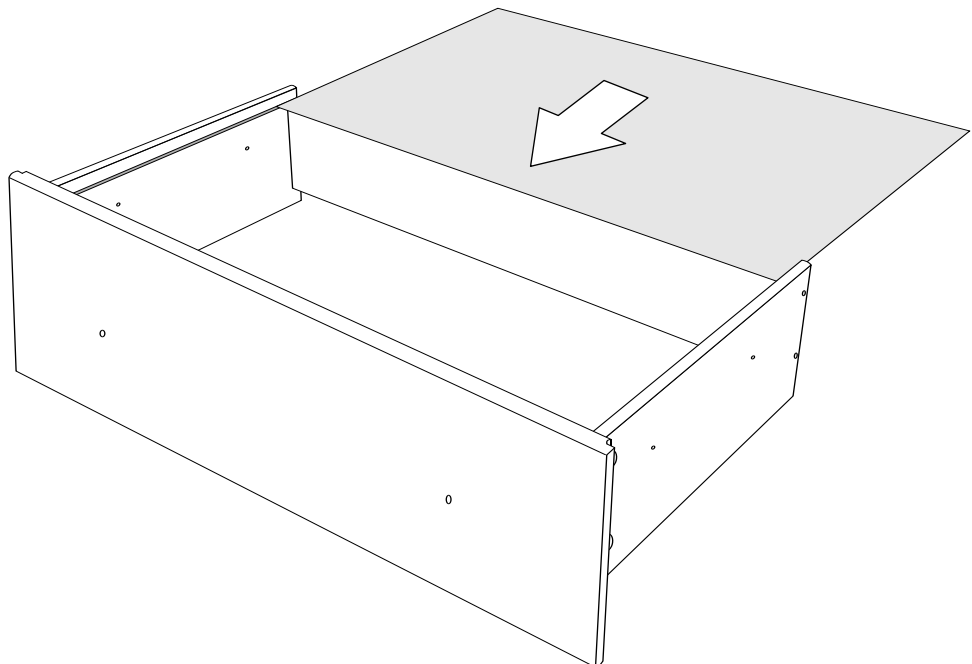
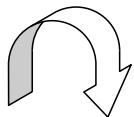

9f

Secure the drawer bottom to the drawer back with nails

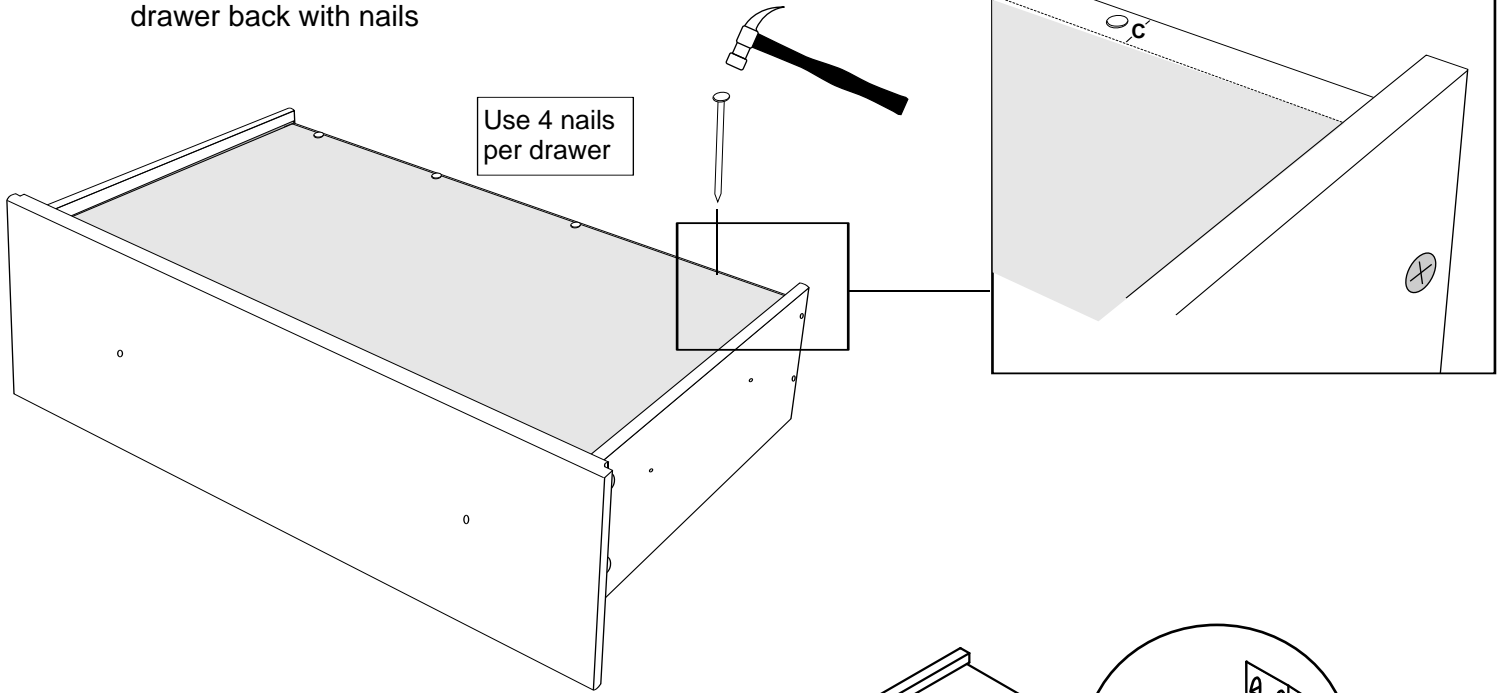

9g

Insert the Drawer Bottom Stabilizer

Position the Stabilizer in the center of the drawer and insert it into the groove on the drawer front. This is the same groove that you inserted the drawer bottom into.

Then, tighten screw until it is flush

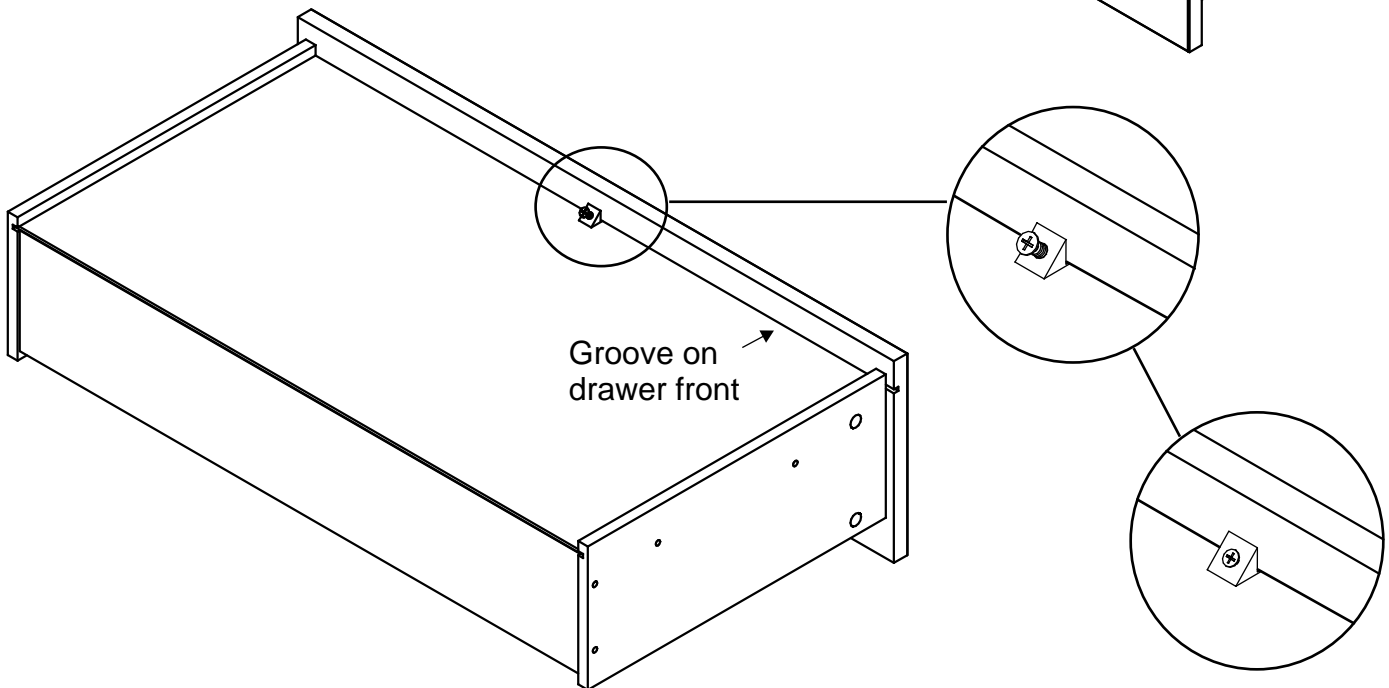
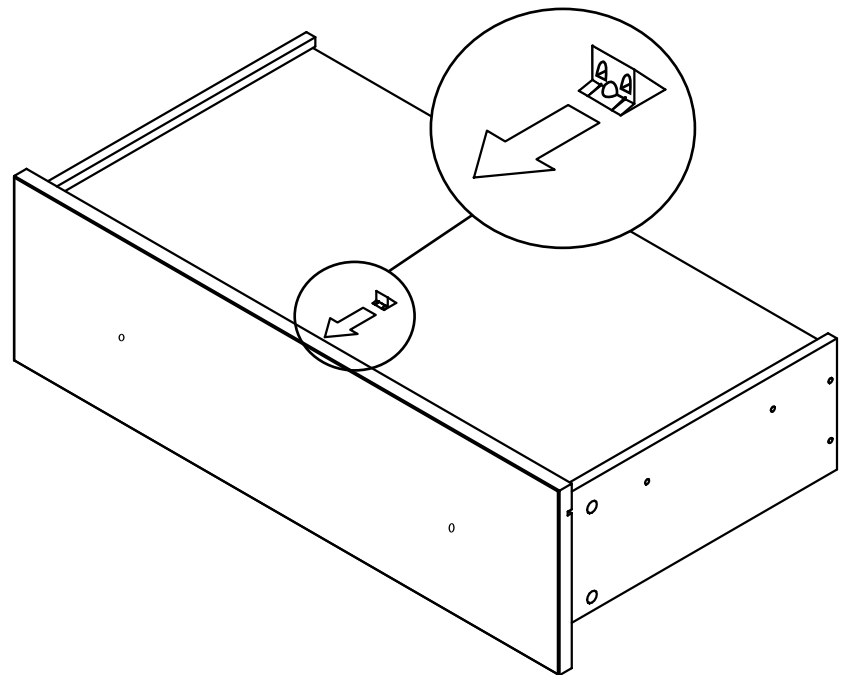

9h

Attach drawer slides to left and right drawer sides using drawer slide screws

Left Drawer Side

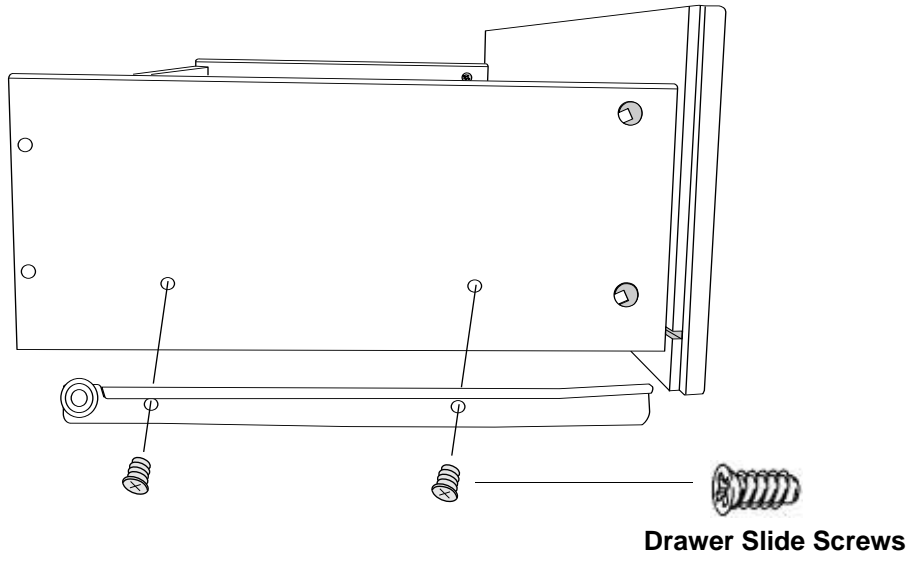

Right Drawer Side

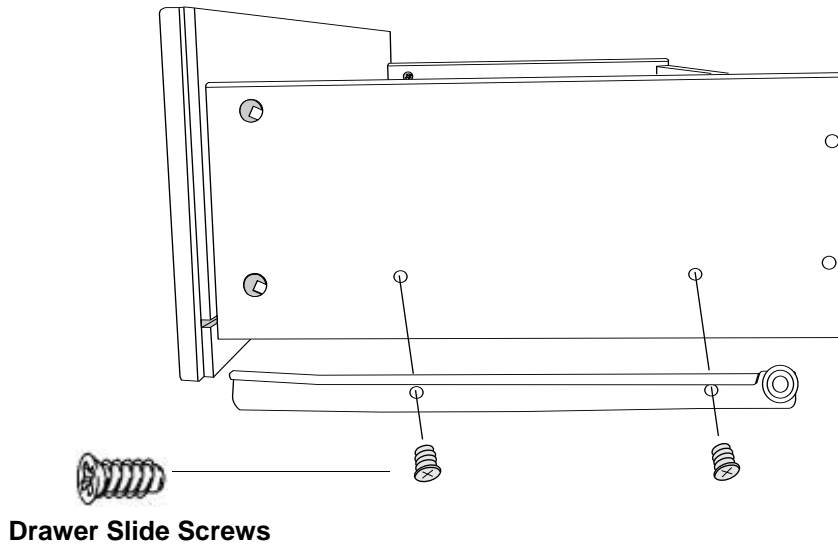

9i

Attach knobs with machine screws

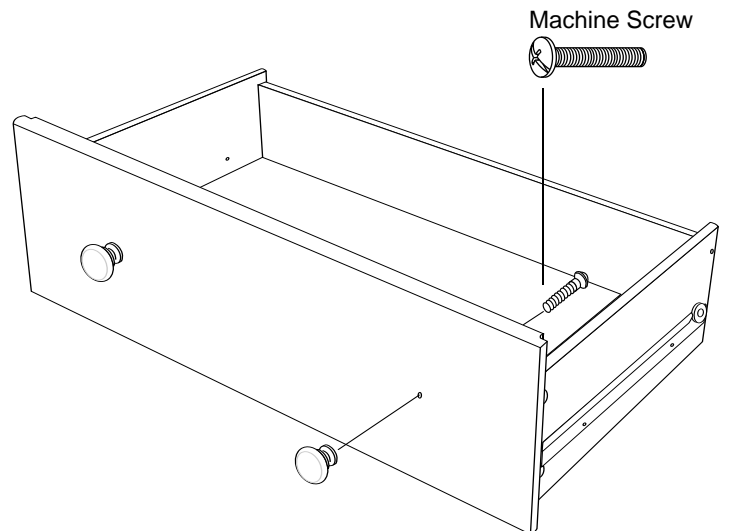

STEP 10 Estimated Time: 2 minutes

Insert drawers

A.

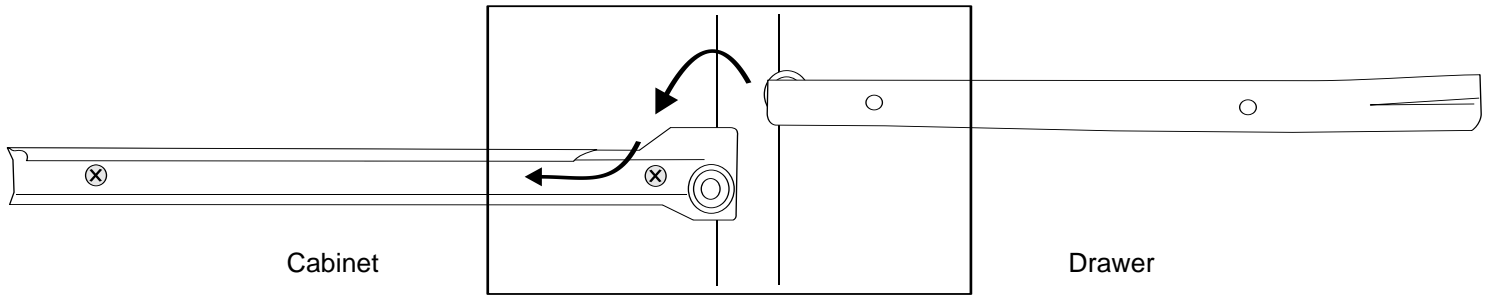
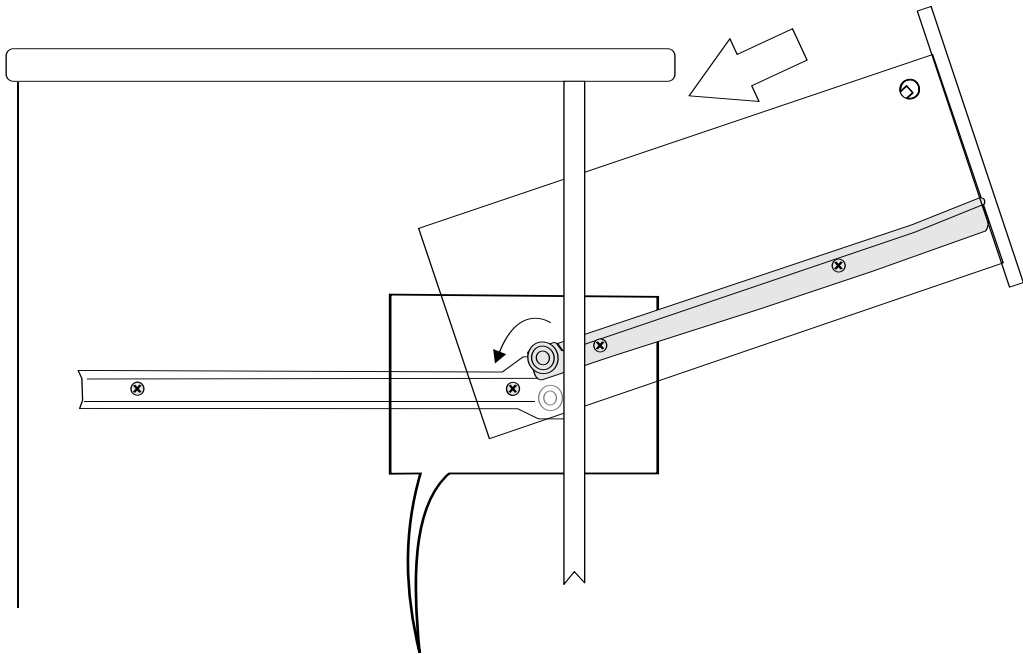

B.

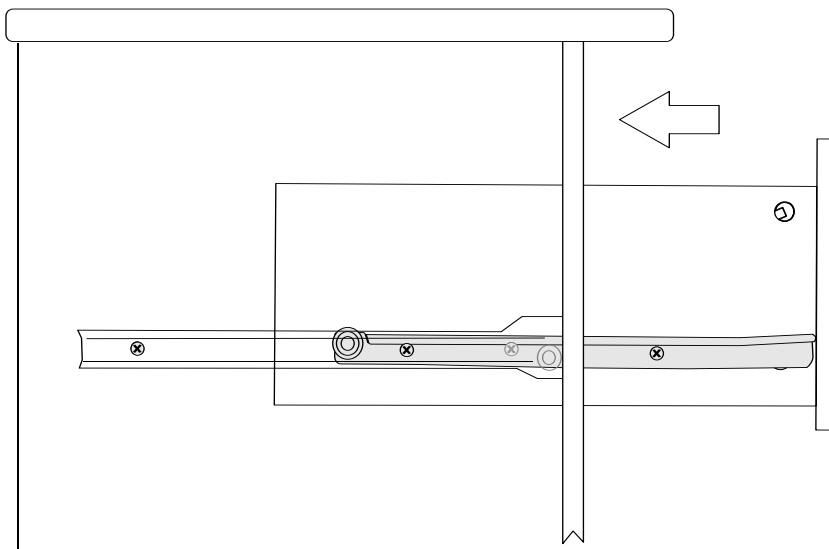

Note: When drawers are installed correctly, you will not be able to remove them without first lifting up the drawer front.

STEP 11 Attaching and Using the Cable Tie

We strongly recommend using a cable tie on all furniture, especially if small children have access

11a. With the #6-3/4" screw, attach one of the mounting bases to one of the sides 1 inch from the top.

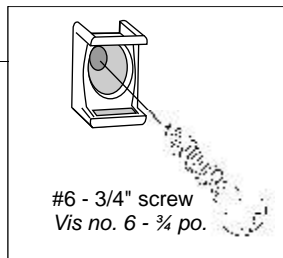
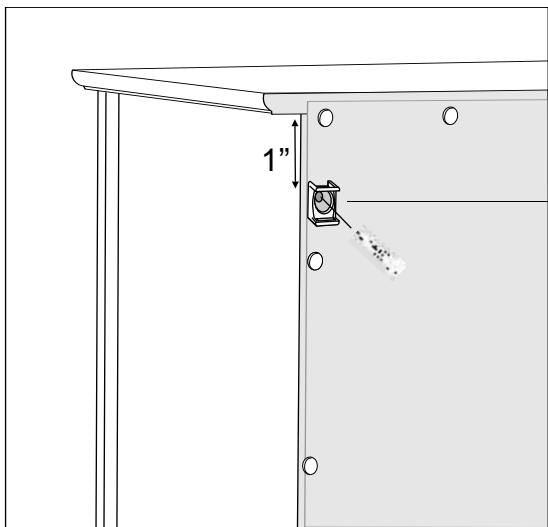

11b. Attach the 2nd mounting base to the wall 2" lower than the one on the cabinet

Important: Find a wall stud and attach the mounting base with a 1 1/2" screw (not included). If you cannot locate a stud, use an approved wall mounting system

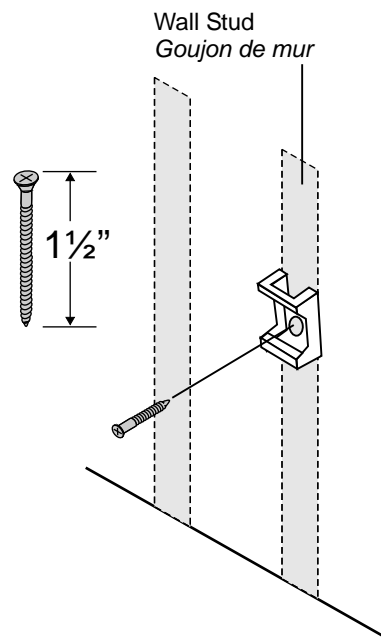

11c. Feed the cable tie through each mounting base and then through the locking mechanism to tighten.

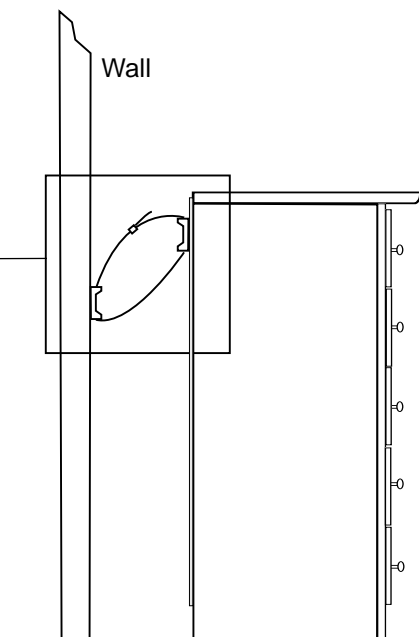
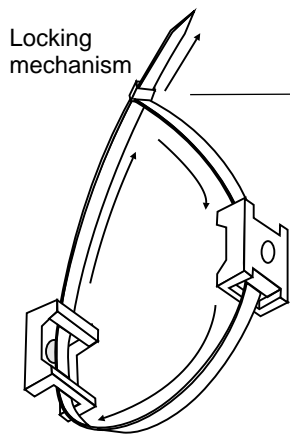

Give Us Your Feedback



CALL US

1-877-PREPAC1 (1-877-773-7221)

Mon - Fri 7am - 4pm PST

10am - 7pm EST

Email Us: assembly@prepacmfg.com

Thanks!