

Assembly Instructions Mode d'assemblage

Console for 60" Plasma TV Console pour le plasma TV de 60"

Series / Série # PS-6000





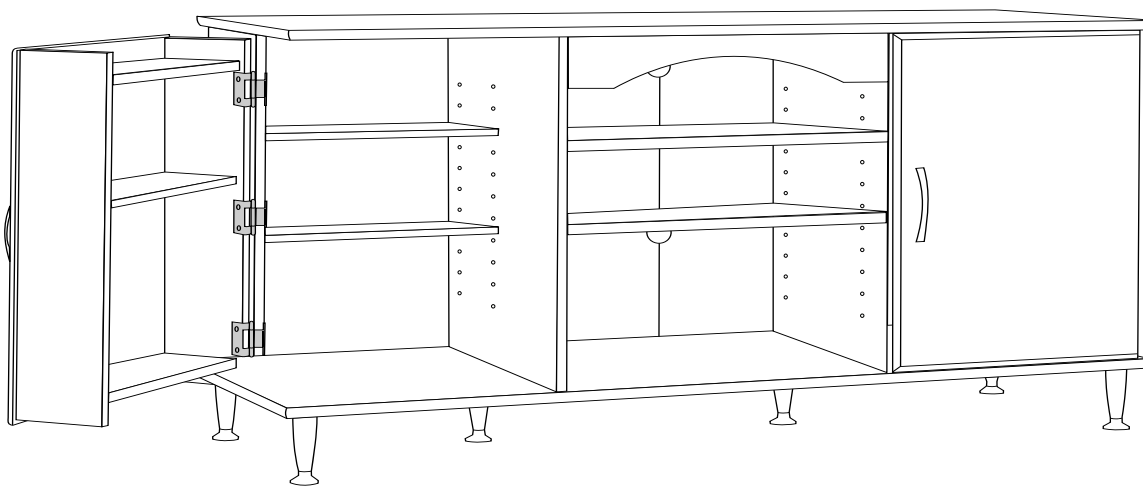







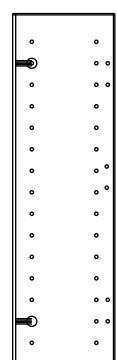
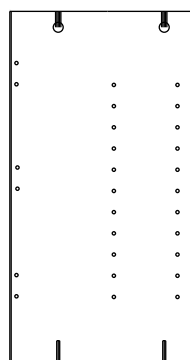
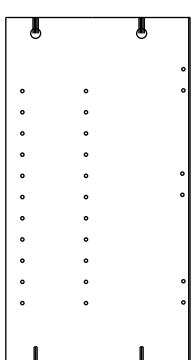
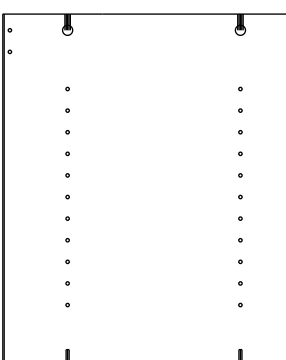
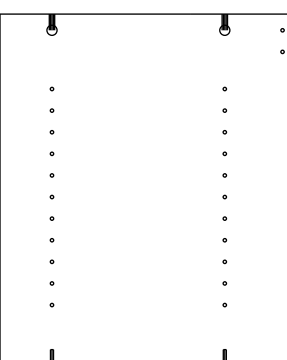
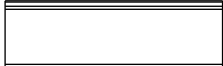

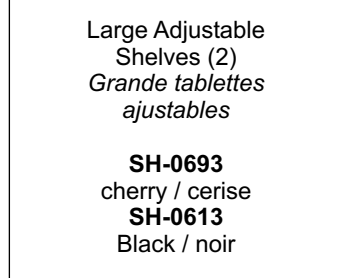
If you have any missing parts, please send an email to parts@prepacmfg.com, visit www.prepacmfg.com or call: **1-877-PREPAC1 (1-877-773-7221) Mon - Fri 7:00am to 4:30pm Pacific Time (10:00am - 7:30pm Eastern)**. Please have your product series number available.

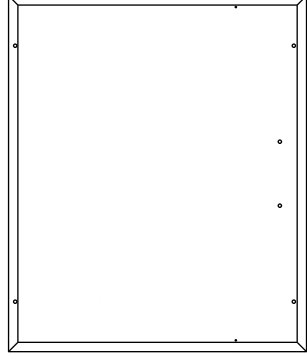
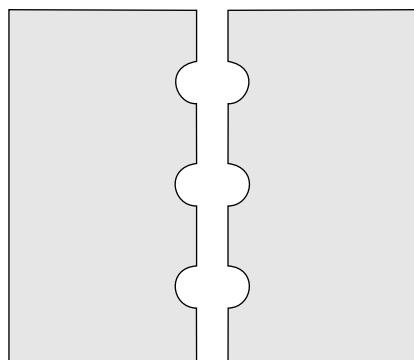
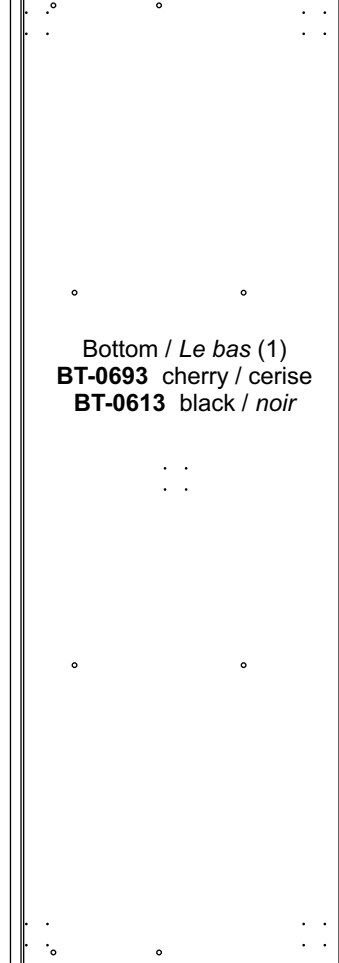
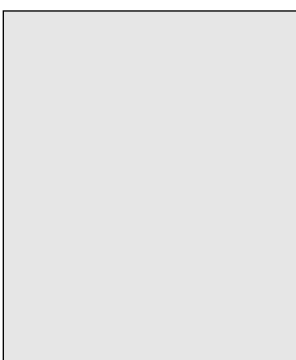
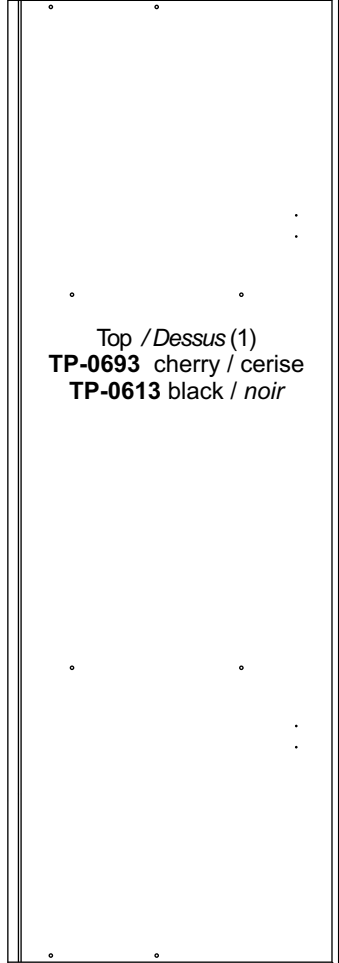
Si des pièces sont manquantes, veuillez envoyer un email à parts@prepacmfg.com, visitez www.prepacmfg.com ou téléphoner au **1-877-PREPAC1 (1-877-773-7221) lors des heures suivantes: LUN - VEN 7h à 16h 30, heure du Pacifique**. Veuillez noter le numéro de série avant de téléphoner. Pour le service en français, contactez s'il vous plaît votre détaillant.

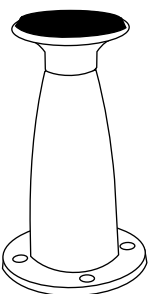

PREPAC™

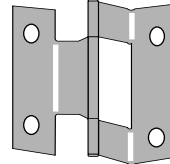
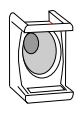
DATE CODE

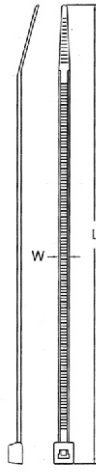
Tools Needed / Outils nécessaires	Cabinet Parts / Pièces de l'armoire				
 Flathead Screwdriver <i>Tournevis principal plat</i>  Phillips Screwdriver <i>Tournevis à pointe cruciforme</i>  Hammer / Marteau	 Door Sides (4) <i>Côtés de la porte</i> SG-0691 cherry / cerise SG-0611 black / noir	 Left Outer Side (1) <i>Côté gauche extérieur</i> SL-0692 cherry / cerise SL-0612 black / noir	 Right Outer Side (1) <i>Côté droit extérieur</i> SR-0692 cherry / cerise SR-0612 black / noir	 Left Inner Side (1) <i>Côté gauche intérieur</i> SL-0693 cherry / cerise SL-0613 black / noir	 Right Inner Side (1) <i>Côté droit intérieur</i> SR-0693 cherry / cerise SR-0613 black / noir
 Long Adjustable Shelves (4) <i>Longues tablettes ajustables</i> SH-0615  Short Adjustable Shelves (2) <i>Petites tablettes ajustables</i> SH-0614 Black / noir  Fixed Door Shelves (4) <i>Tablettes fixe de porte</i> DO-0612 Black / noir	 Large Adjustable Shelves (2) <i>Grande tablettes ajustables</i> SH-0693 cherry / cerise SH-0613 Black / noir  Stabilizer / Renforcement (1) ST-0692 cherry / cerise ST-0612 black / noir	 Door (2) <i>Porte</i> DR-0693 cherry / cerise DR-0613 black / noir  Inside Backer (2) <i>Dos intérieur</i> BB-0611	 Bottom / Le bas (1) BT-0693 cherry / cerise BT-0613 black / noir  Outside Backer (2) <i>Dos extérieur</i> BB-0613	 Top / Dessus (1) TP-0693 cherry / cerise TP-0613 black / noir	
Hardware / Quincaillerie		<p>HP-0736</p>  Satin Nickel Handle (2) RM-0300  #4-20mm Machine Screw (4) <i>Vis de machine de 20mm</i> RM-0471  Wood Dowel (4) <i>Goujon de bois</i> RM-0069	<p>HP-0899</p>  #8 - 5/8" Screw <i>Vis no. 8 - 5/8 po.</i> (24) RM-0394  Nickel Finished Adjustable Legs <i>Pieds ajustable en finition nickel</i> (6) RM-0662	<p>HP-0588</p>  Drawer Slide Screw (24) <i>Vis pour coulisse de tiroir</i> RM-0074  Hinge <i>Penture</i> (6) RM-0638	<p>HP-0608</p>  Mounting Base (2) <i>Base de support</i> RM-0458  #6-3/4" Pan Head Screw (1) <i>Vis #6-3/4 po.</i> RM-0460  Cable Tie (1) <i>Attache pour câble</i> RM-0459

- 1.** Attach the bottom to sides using Confirmat Screws.
Fixez le bas aux côtés à l'aide des vis Confirmat

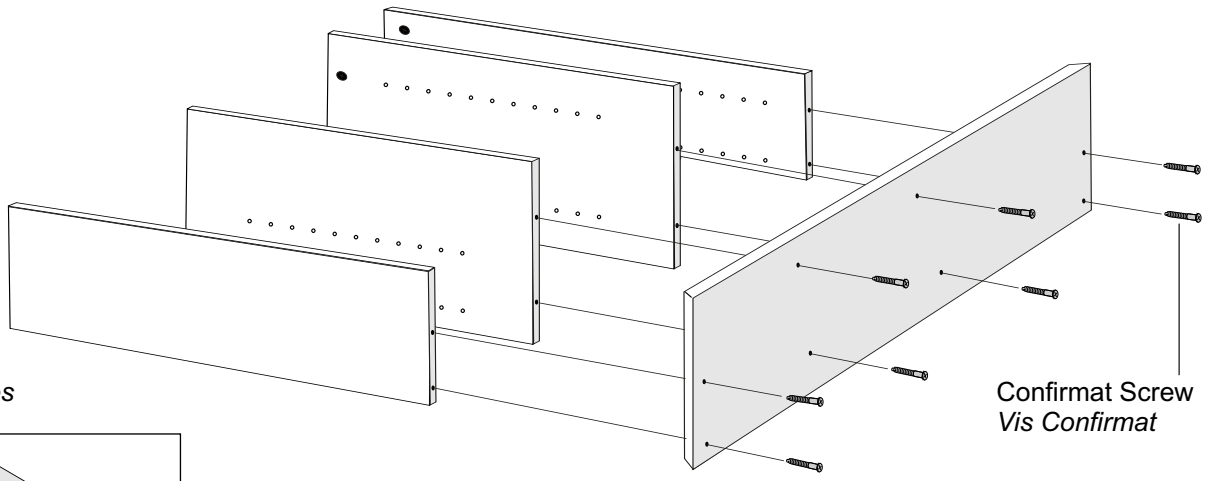

- 2.** Insert cams into the **top** of all sides.
*Insérez les ferrures **au dessus** de chacun des côtés*

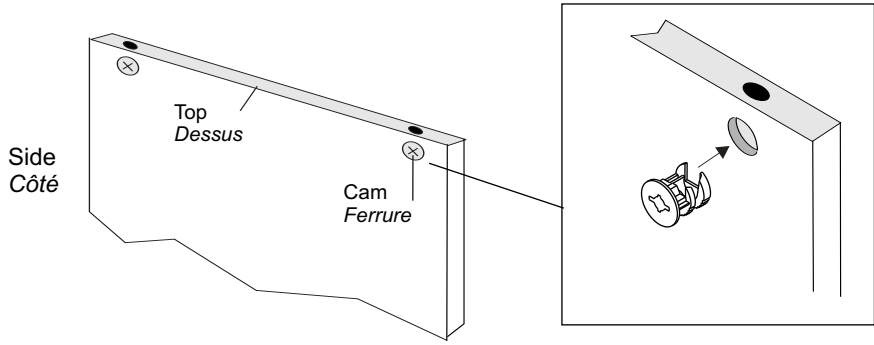

ONLINE HELP



To see a video showing how the cam and connectors work, visit our website:
www.prepacmfg.com/support/assemblyvideos.html

Confirmat Screw
 Vis Confirmat

- 3.** Attach stabilizer with wood dowels
Attachez le stabilisateur avec les goujons de bois

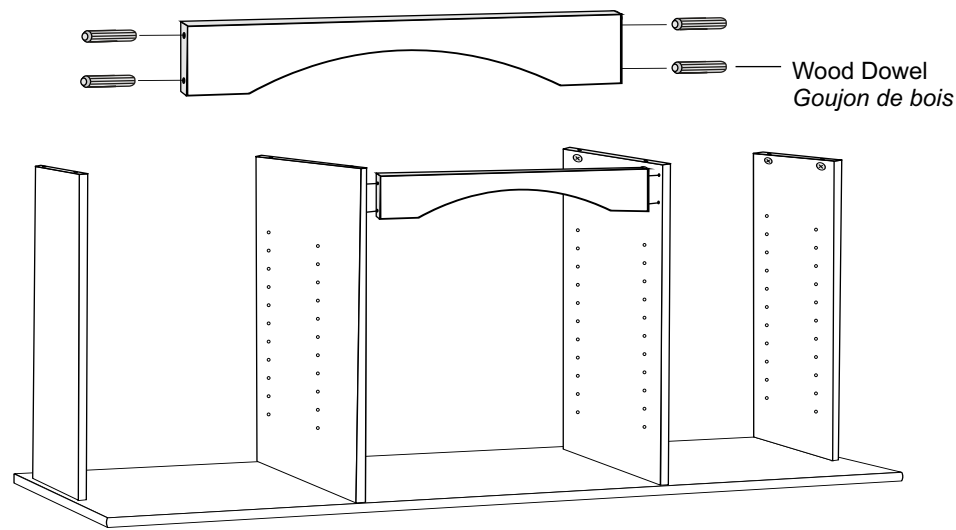

- 4.** Screw **green twister dowels** and **magnetic catches** into the underside of the top.
*Vissez les **goujon de torsion vert** et les attaches magnétique dans le dessous du dessus.*

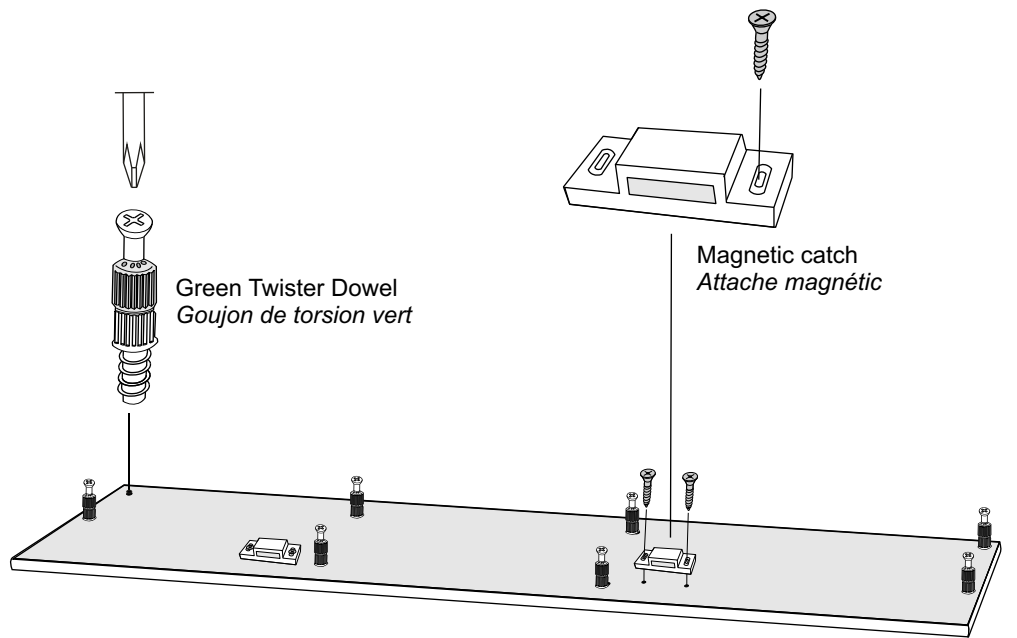

- 5.** Turn top over, attach to sides & tighten cams.
Faites tourner le dessus, fixez aux côtés et serrez les ferrures.

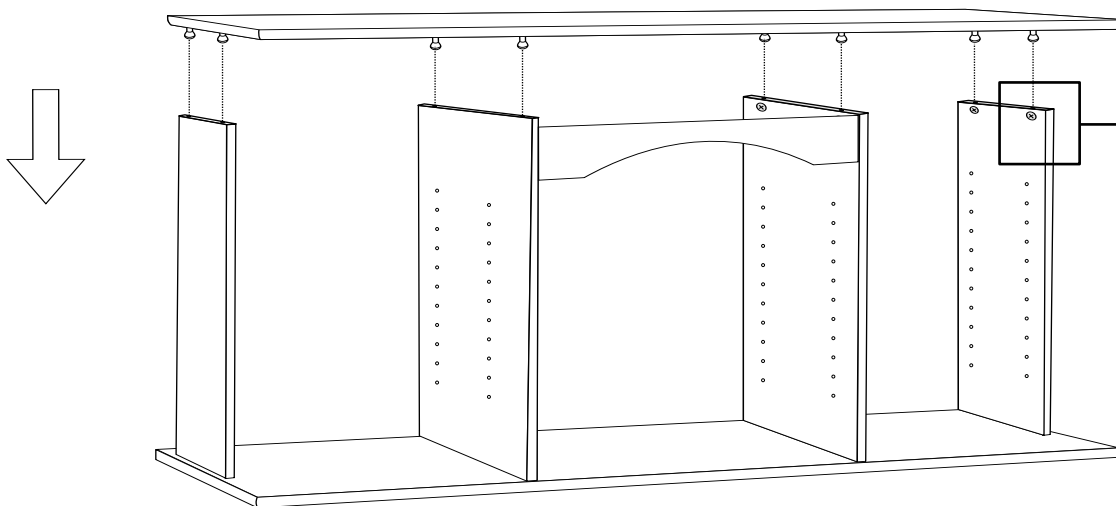

Tightening Cams
Serrez les ferrures

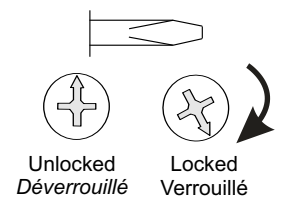

- 6.** Turn upside down and attach feet
Faites tourner le dessus, fixez aux côtés et serrez les ferrures.

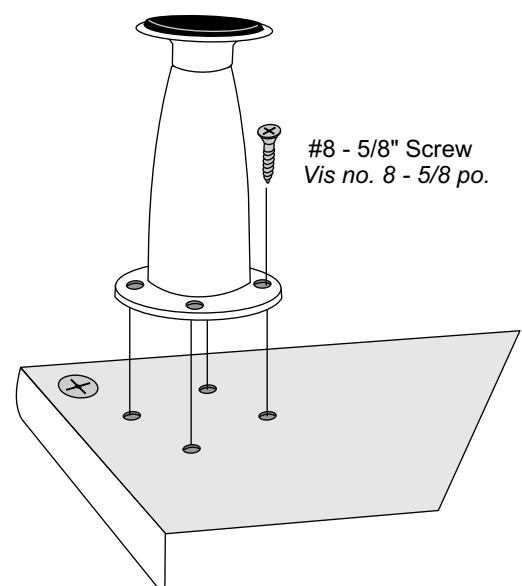
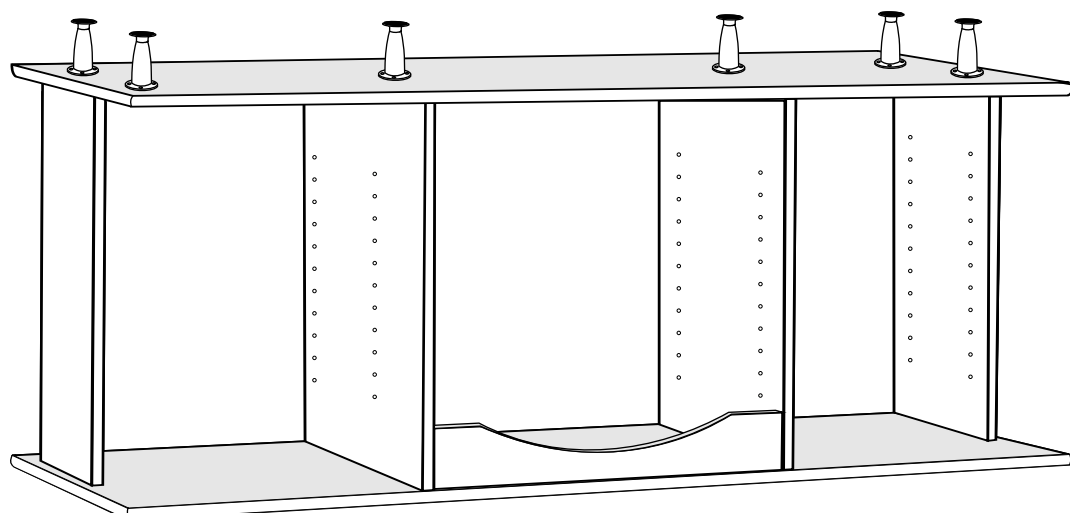

Assembling and Attaching the Doors / Assembler et fixer les portes

- 7.** Insert cams into fixed shelves and all 4 door sides
Insérez les ferrures dans les tablettes fixes et chacun des 4 côtés de porte

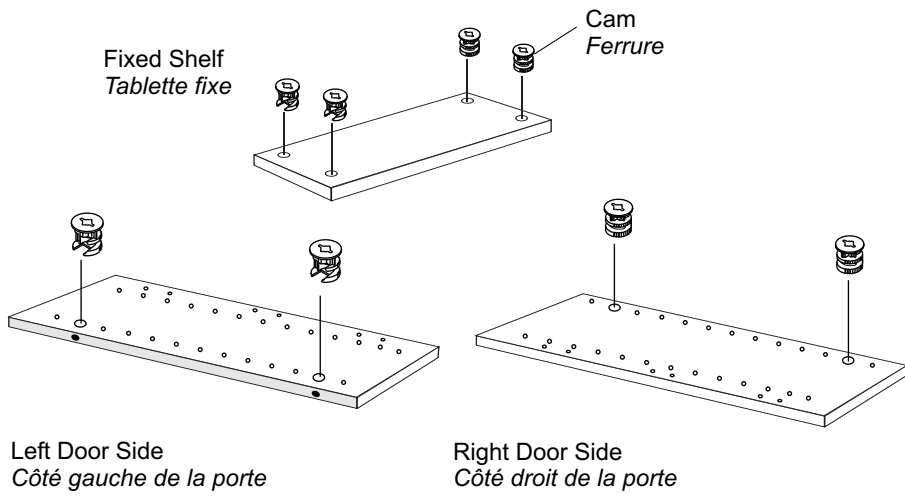

- 8.** Insert **green twister dowels** into the bottom and top row on ALL door sides.
*Insérez les **goujon de torsion vert** dans le fond et la rangée supérieure de TOUS LES côtés de porte.*

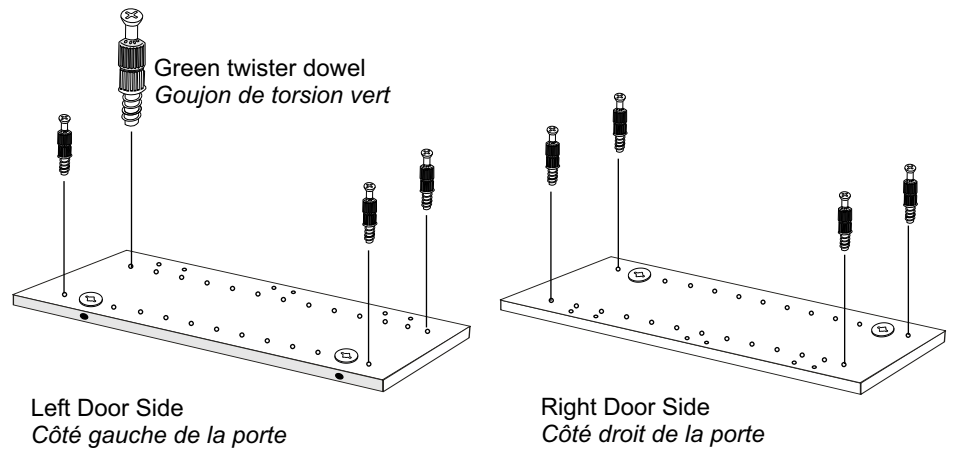

- 9.** Attach Door Sides to fixed shelves and tighten cams.
Fixez les côtés de la porte aux tablettes fixes et serrez les ferrures.

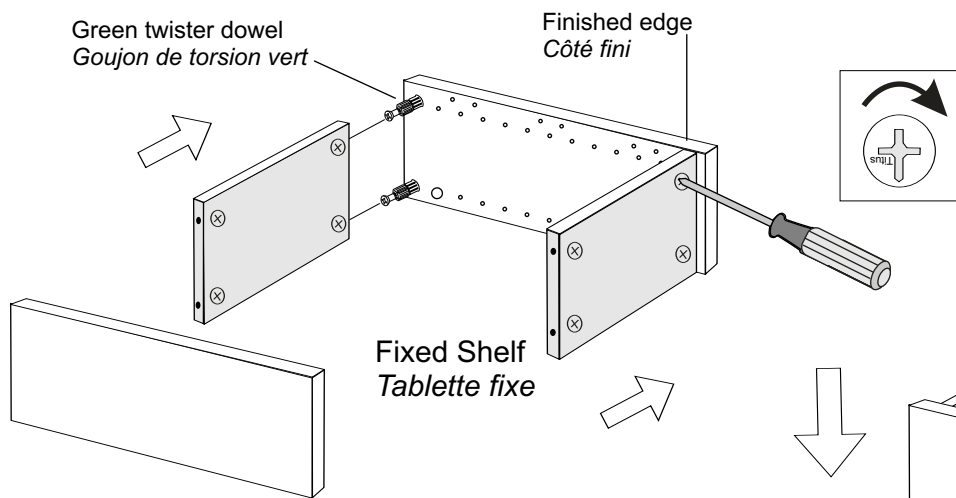

- 10.** Insert green twister dowels into each door front.
Insérez les goujons de torsion vert dans le devant des portes.

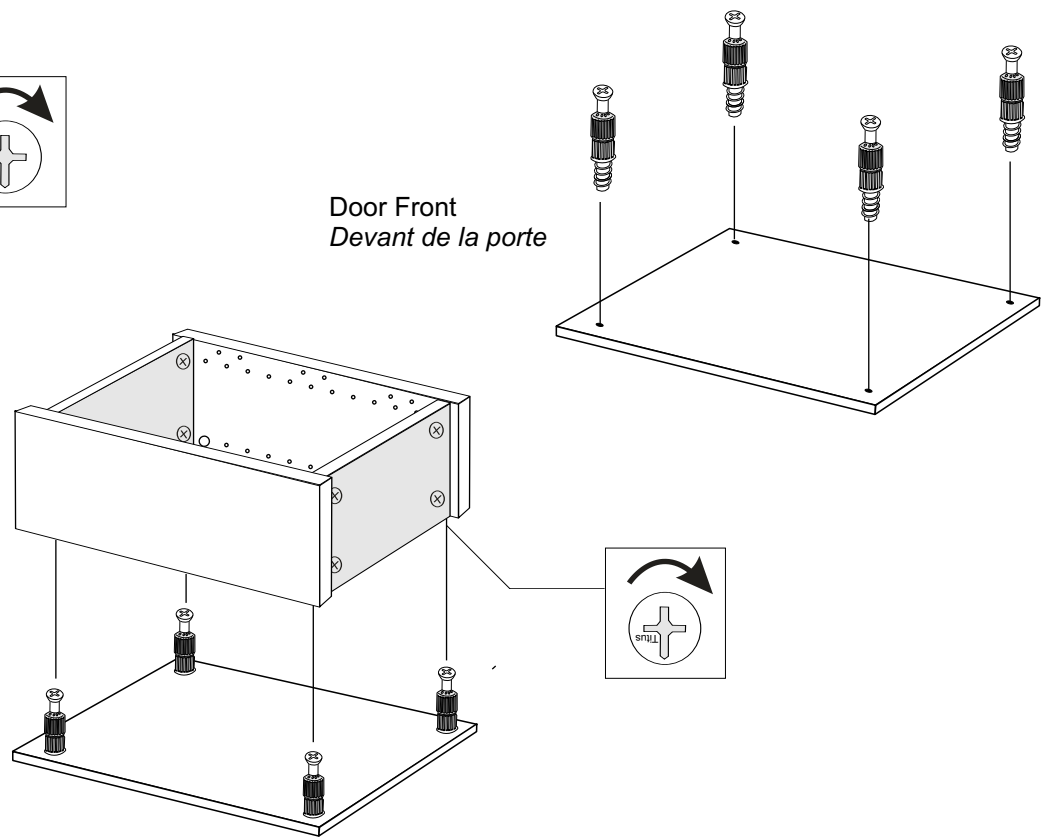

- 11.** Attach door sides to door fronts and tighten cams
Fixez les côtés de la porte au devant des portes et serrez les ferrures.

- 12.** Attach hinges to cabinet side. Then, align door with cabinet and attach hinges to door.
Posez les pentures aux côtés de l'armoire. Alignez ensuite la porte avec l'armoire et fixez les pentures à la porte.

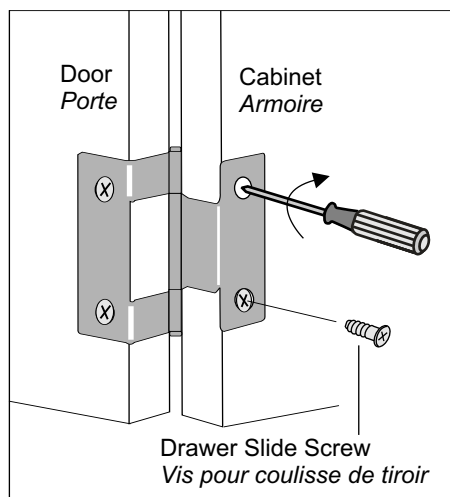

- 13.** Insert metal dowels into shelf holes and add adjustable shelves. Shelves for doors and cabinet vary slightly in size.
Insérez les goujons de métal dans les trous des tablettes ajustable et posez les tablettes. Les tablettes pour des portes et le coffret changent légèrement dans la taille.

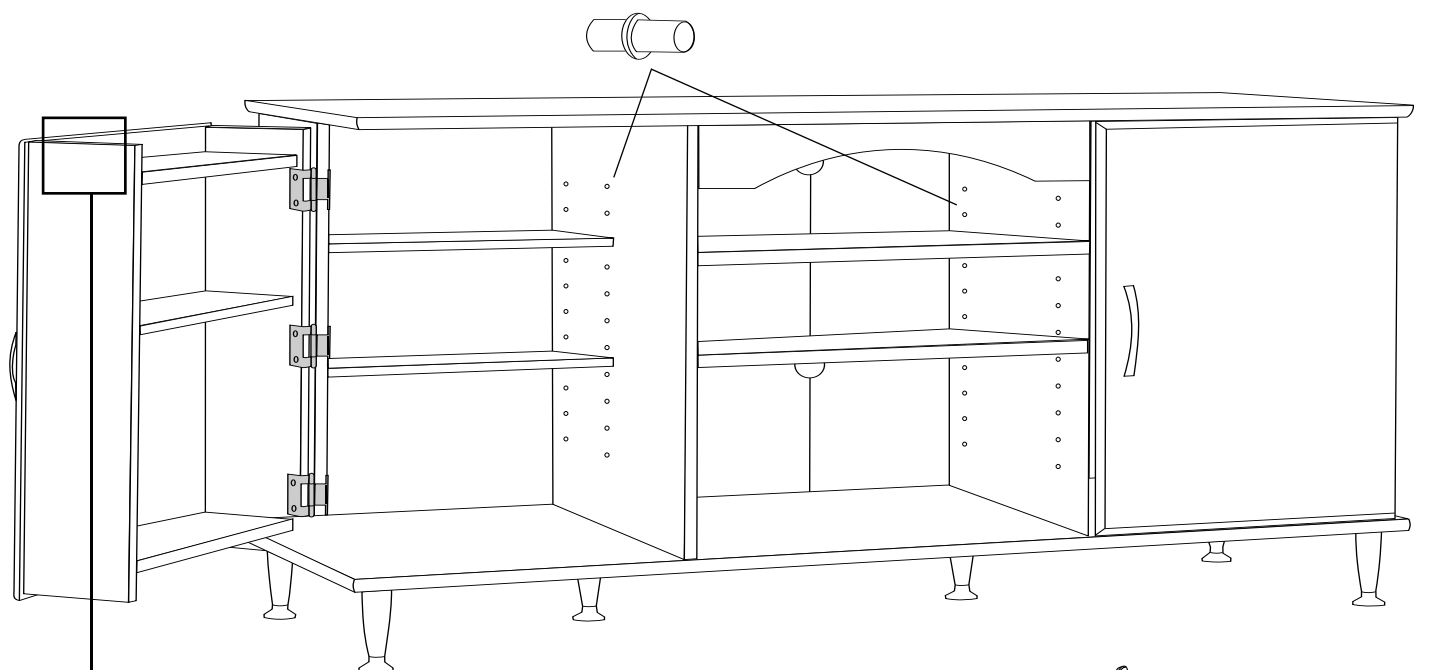

- 14.** Attach the metal plates to the top of **each** door with screw supplied.
Posez les plaques métalliques au-dessus de chaque porte la vis étant fourni.

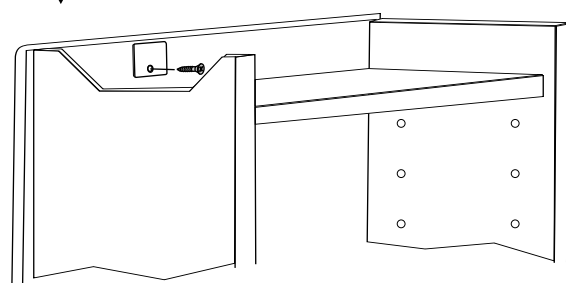

- 15.** Attach nickel finished metal handles
Fixez les poignée métallique en finition nickel satinée

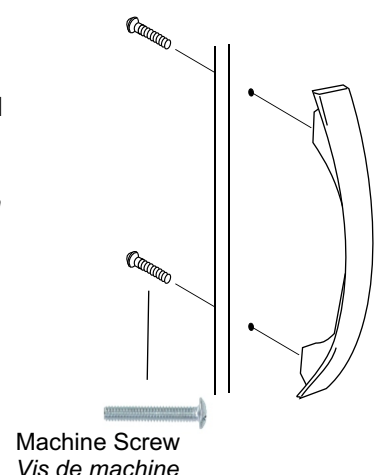

- 16.** Attach the two **outer backers** to top and sides using **3/4" nails**. Leave 2-3 inches space from each corner.

*Attachez les deux **dos extérieures** à l'aide des **clou 3/4 po.** Laissez des 2 ou 3 " l'espace de chaque coin.*

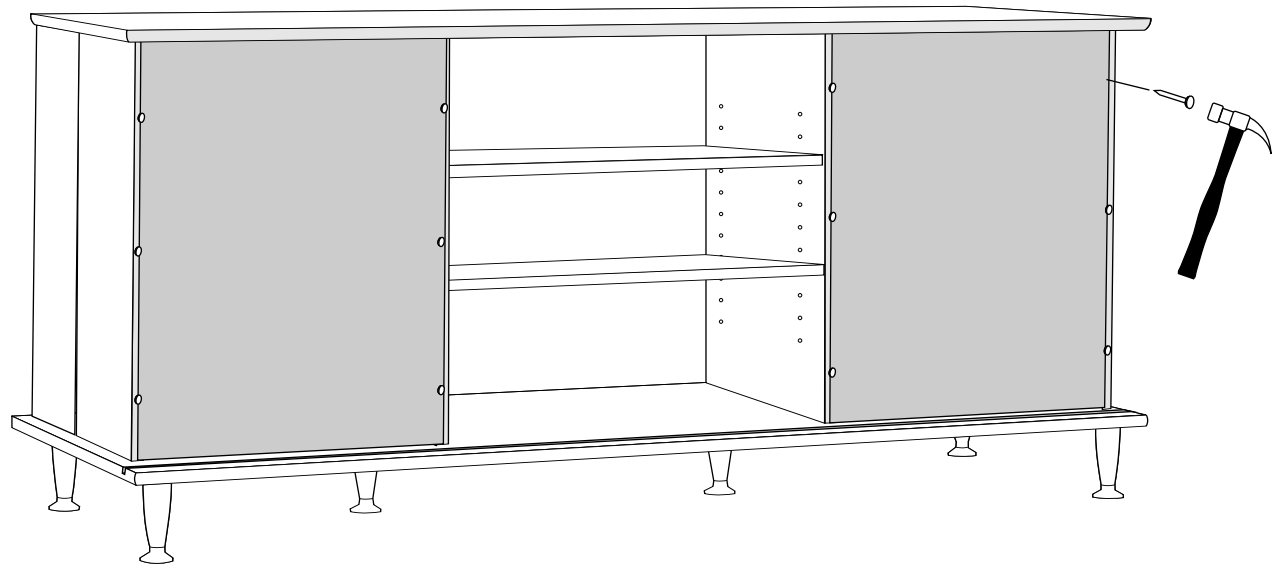

- 17.** Slide inner backers along the rear groove. Slide open and closed to access electronic components

Glissez les appuis intérieurs le long de la cannelure arrière. Glissière ouverte et fermée aux composants électroniques d'accès

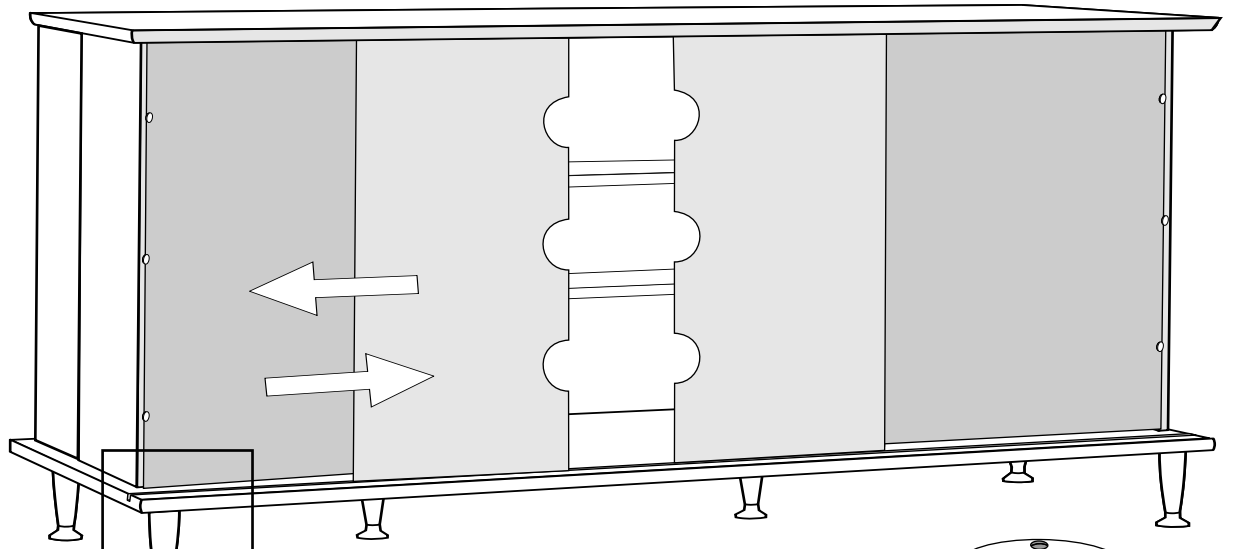
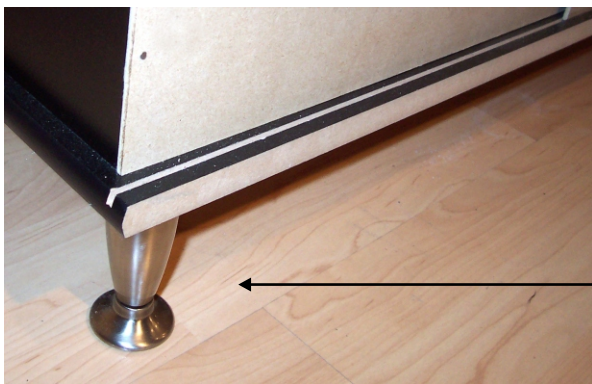

- 18.** If your floor is uneven, tighten or loosen bottom of legs to adjust height. *loosen bottom of legs to adjust height.*

Si votre plancher est inégal, serrez ou détachez le fond des jambes pour ajuster la taille.

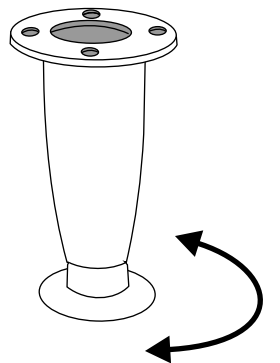

Secure Plasma TV Stand to wall using the Cable Ties (see next step for details)

Fixez le stand du plasma TV au mur en utilisant l'attache pour câble (voir la prochaine étape pour des détails)

- 19a.** With the #6-3/4" screw, attach one of the mounting bases to the center gable 1 inch from the top.
Avec #6 le 3/4 " vis, attachez un des bases de support au pignon central 1 pouce de l'attache supérieure.

- 19b.** Attach the 2nd mounting base to the wall 2" lower than the one on the cabinet
Important: Find a wall stud and attach the mounting base with a 1 1/2" screw (not included). If you cannot locate a stud, use an approved wall mounting system

Le 2ème base de support au mur 2 " inférieurs à celui sur le module.

Important: *Trouvez un goujon de mur et attachez la base de support avec la " vis un 1 1/2 (non inclus). Si vous ne pouvez pas localiser un goujon, utilisez un système approuvé de support de mur*

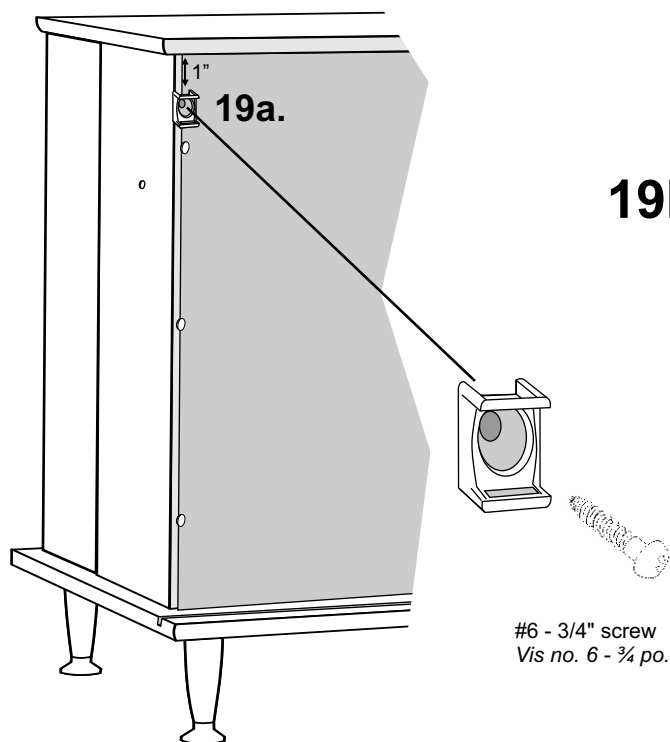

#6 - 3/4" screw
Vis no. 6 - 3/4 po.

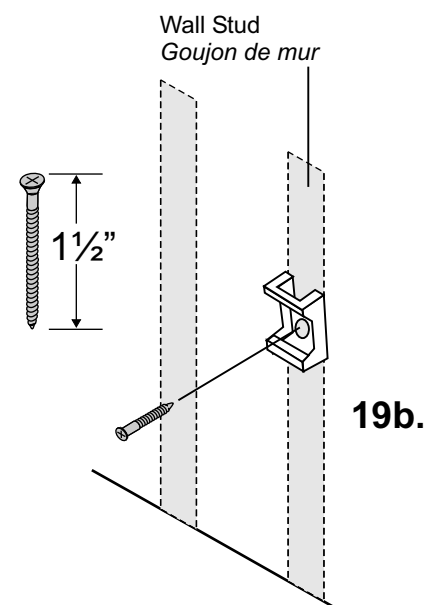

We recommend you screw into a stud. If you cannot locate a stud use a wall anchor appropriate for your type of wall.

Nous vous recommandons vis dans un goujon. Si vous ne pouvez pas localiser une utilisation de goujon une ancre de mur appropriée pour votre type de mur.

- 20.** Feed the cable tie through each mounting base and then through the locking mechanism to tighten.

Alimentez le serre-câble par chaque base de support et alors par le dispositif de verrouillage pour serrer.

