



Assembly Instructions

Queen Platform Storage Bed

Model # BQ-6200-3K

This product is shipped in **3 cartons**

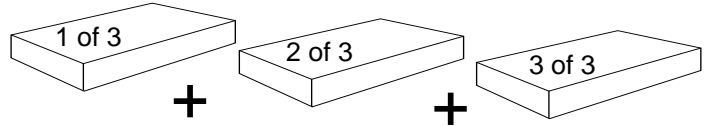

Make sure you have all cartons. Sometimes cartons shipped on the same day get separated and are delivered on different days.

DATE STAMP

CALL US FIRST
1-877-PREPAC1
1-877-773-7221



Mon - Fri 7am - 4pm PST
10am - 7pm EST

- For help with assembly
- If you have received a damaged or defective part or are missing hardware.

We will process replacement parts in 2 business days or less. Parts are shipped via UPS Ground or mail.



Before you call please:

- 1) Record the following information from the shipping label on the outside of the box. You will need it for warranty purposes:
 - Ship To Name
 - Sales Order Number
- 2) Note the product model number.
- 3) Review the contents of your shipment to determine what you are missing. This unit is shipped in 3 cartons. Make sure you have received all cartons.



Online Option:

Fill out the Replacement Parts Order form in the Product Support section of our website: www.prepacmfg.com

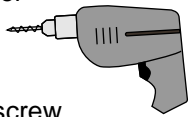
Required Tools	Optional Tools
<p>Screwdrivers</p>  <p>Phillips Head</p>  <p>Flat Head</p>  <p>Hammer</p>	<p>Using a power screwdriver will speed up assembly.</p>  <p>Caution Do not over tighten any screw. The last few turns of each screw should be done very slowly or by hand.</p>

Prepac Manufacturing Ltd.
6705 Dennett Place
Delta, BC V4G 1N4

LB-0625-R
2012-06-20

Hardware Identification

Bed Hardware



JRN Nut
(24)
RM-0312

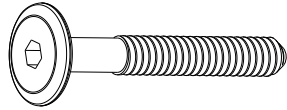

JCB Connector
(24)
RM-0310 bronze (cherry / espresso)
RM-0311 chrome (white / maple)
RM-0314 black

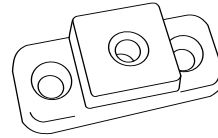

T Spacer
(24)
RM-0628



Drawer Slide Screw
(90)
RM-0074



Allen Key
(1)
RM-0313

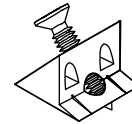

Drawer Bottom
Stabilizer (6)
RM-0839

Drawer Slides for Bed

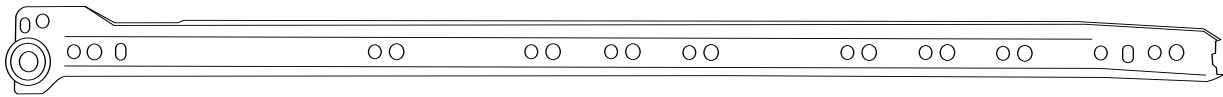

LEFT Slide (6)

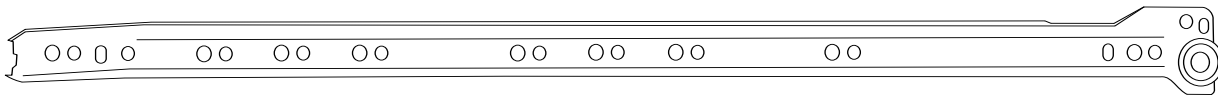

RIGHT Slide (6)

Drawer Hardware

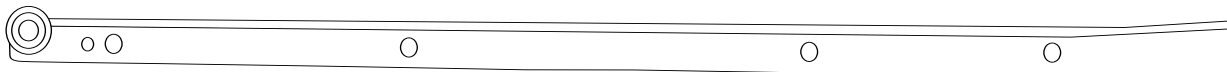

1 LEFT Drawer Slide per Drawer (Total = 6)

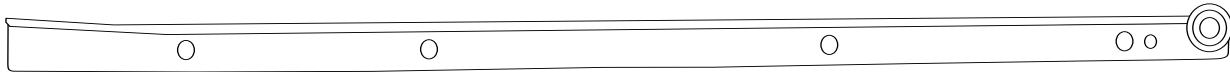

1 RIGHT Drawer Slide per Drawer (Total = 6)

4 per drawer



#8 - 1 1/2" Hi Lo Screws
(24)
RM-0504



12mm Zinc Cam
(24)
RM-0715

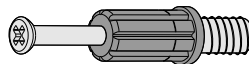

34mm Black Twister Dowel
(24)
RM-0500

5 per drawer

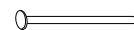

3/4" Nail
(30)
RM-0022

8 per drawer



Drawer Slide Screw
(48)
RM-0074

Bed Parts

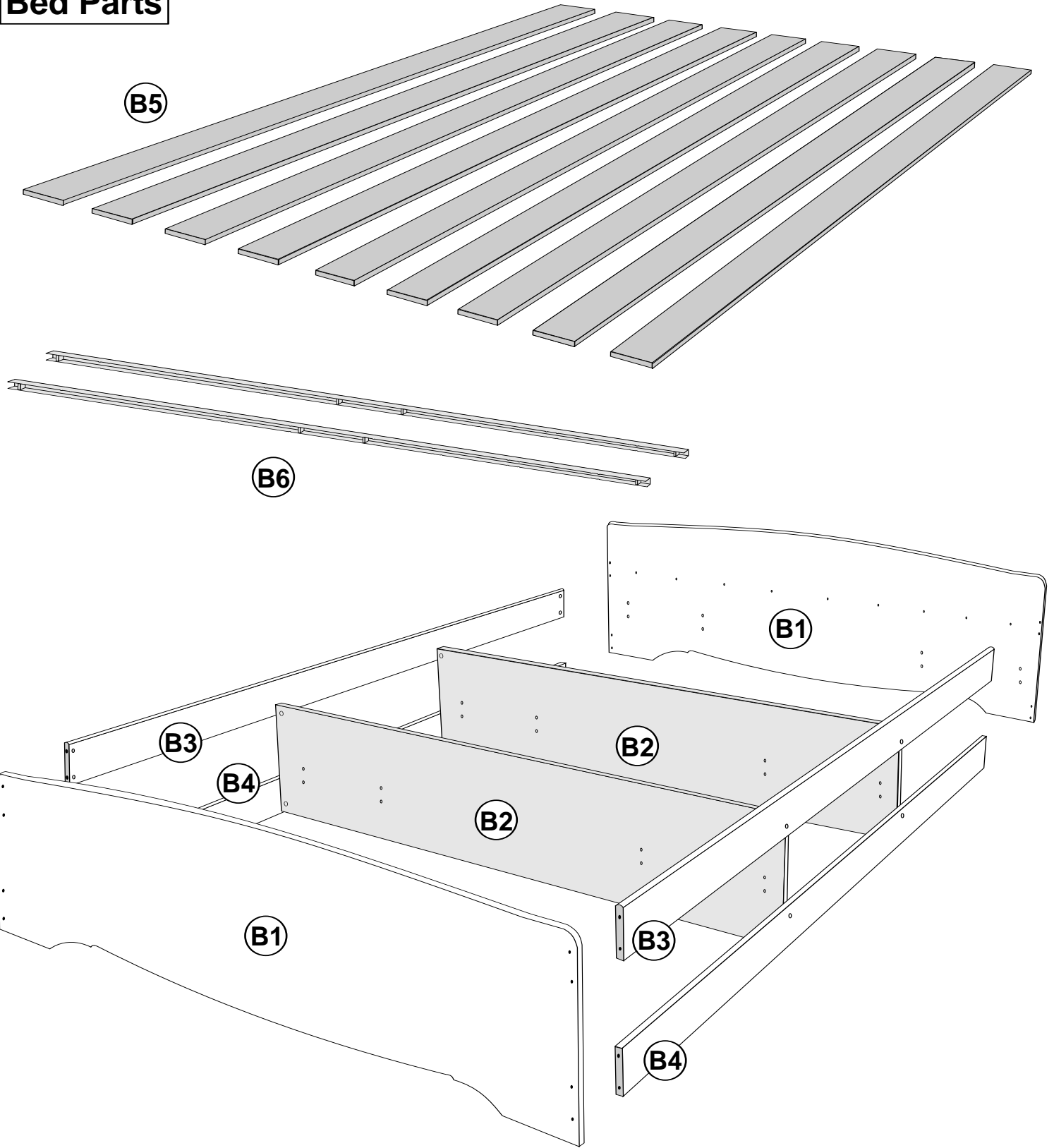

(B1)

Outer Gables (2)
GA-4120 black
GA-4920 cherry
GA-4620 espresso
GA-4720 maple
GA-4020 white

(B2)

Inner Gables (2)
GA-4108 black
GA-4908 cherry
GA-4608 espresso
GA-4708 maple
GA-4008 white

(B3)

Upper Stabilizer (2)
ST-4120 black
ST-4920 cherry
ST-4620 espresso
ST-4720 maple
ST-4020 white

(B4)

Lower Stabilizer (2)
ST-4121 black
ST-4921 cherry
ST-4621 espresso
ST-4721 maple
ST-4021 white

(B5)

Plywood Slats (9)
BF-2000-PW

(B6)

Metal U-channel with
 Blocks (2)
BF-3000-C

STEP 1 Estimated Time: 10 minutes

Attach metal U-channels to each outer gable using drawer slide screws

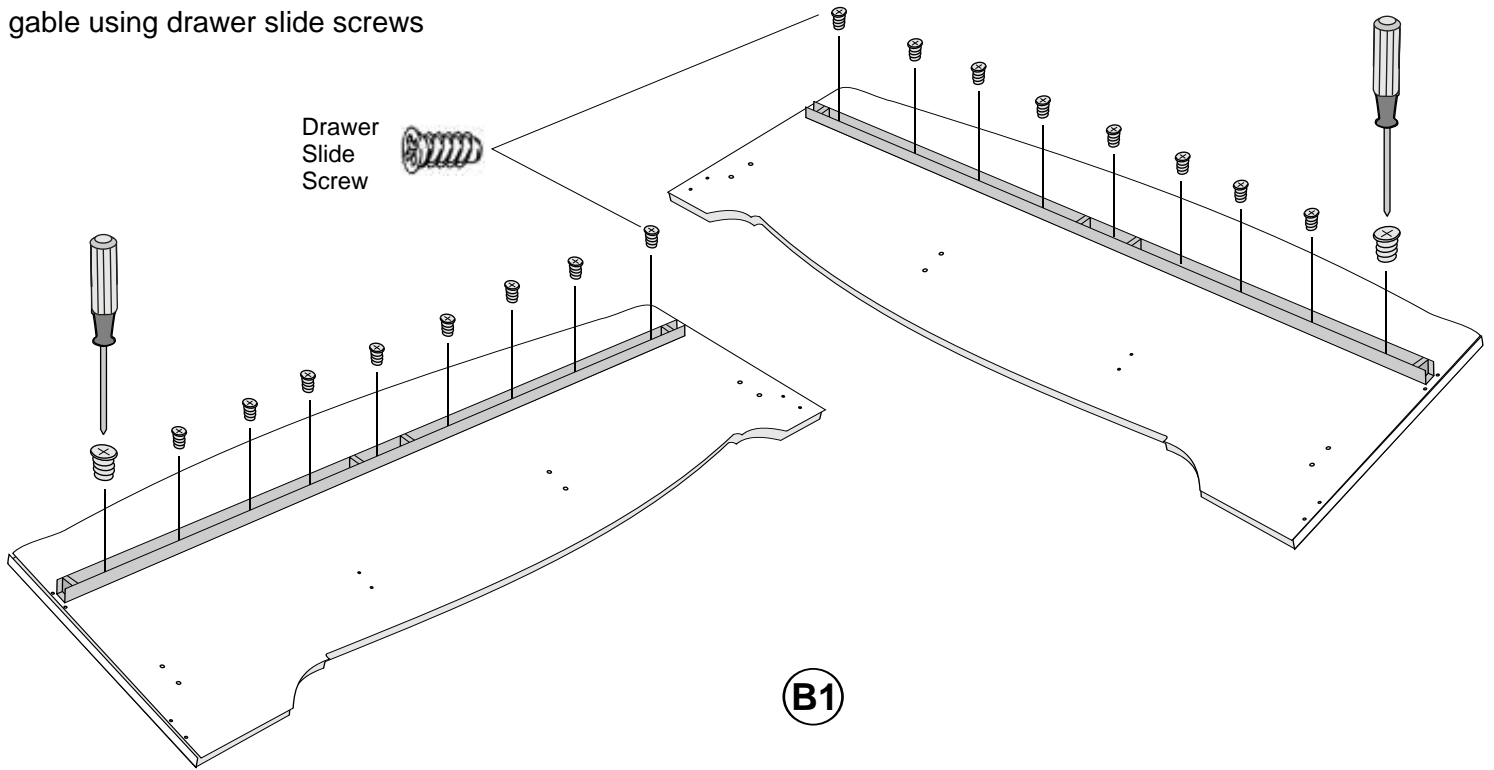

B1

STEP 2 Estimated Time: 15 minutes

Attach T spacers to outer gables with drawer slide screws.

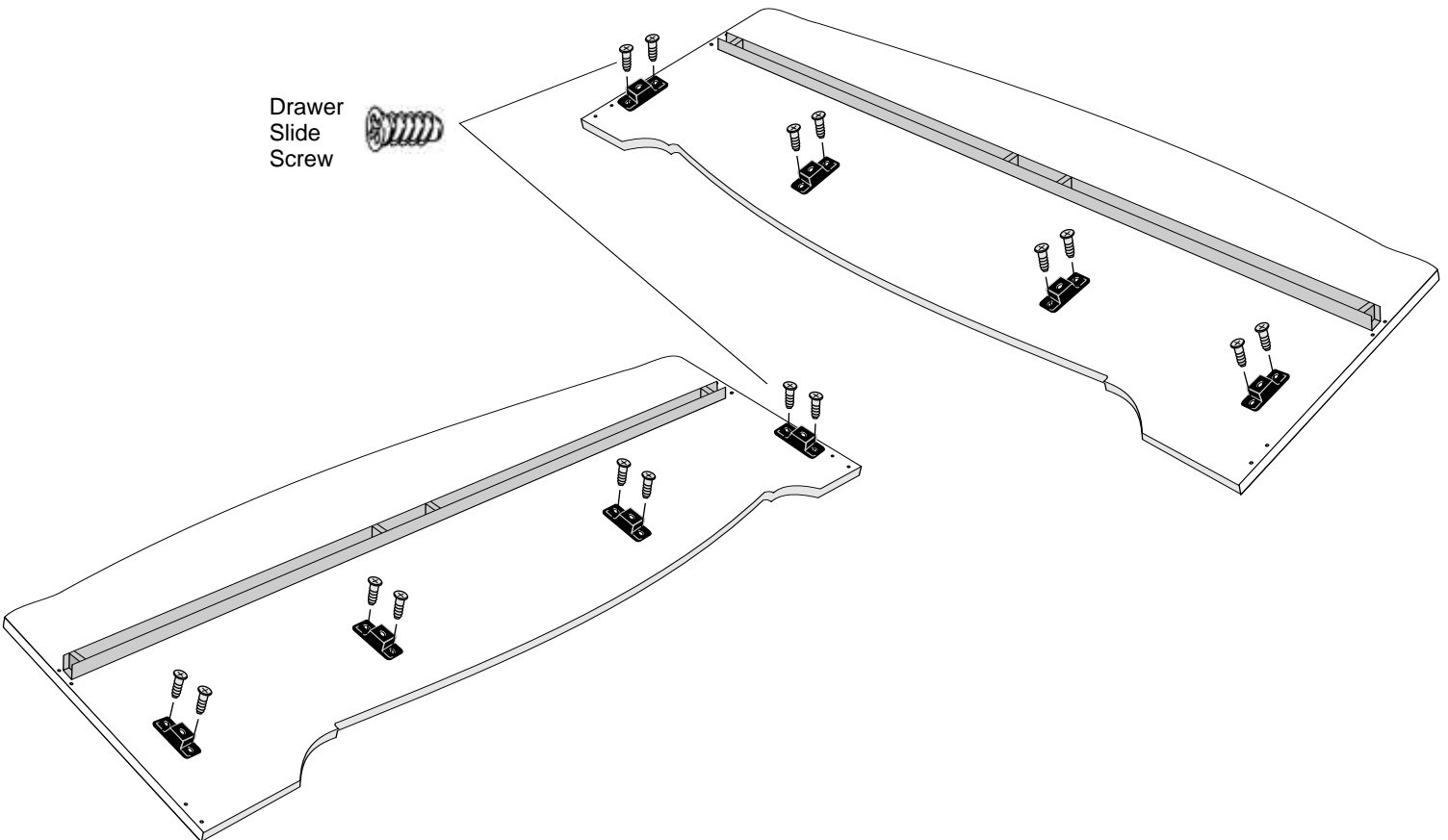

STEP 3 Estimated Time: 10 minutes

Attach drawer glides to T-spacers on outer gables as shown in the photo

Position the Drawer Glides with:

- A) The wheel at the finished side
- B) The wheel on the unfinished bottom

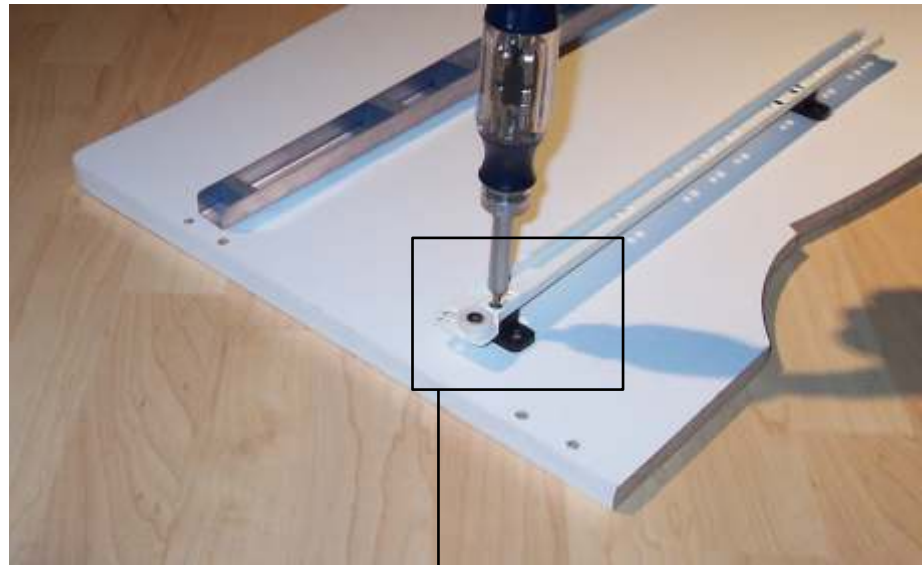
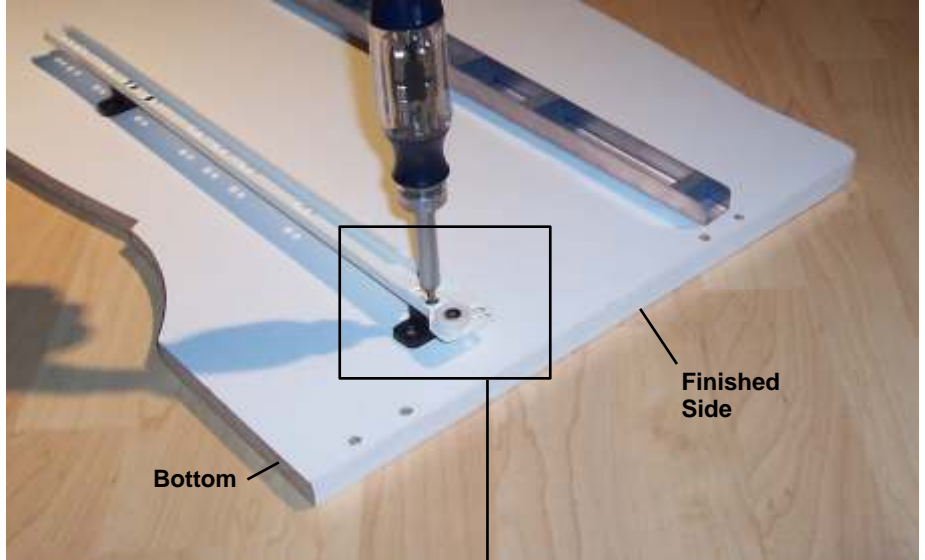

STEP 4 Estimated Time: 5 minutes

Insert JRN nuts into the holes on each end of the inner gables.

The holes are drilled through. You can insert them from either side.

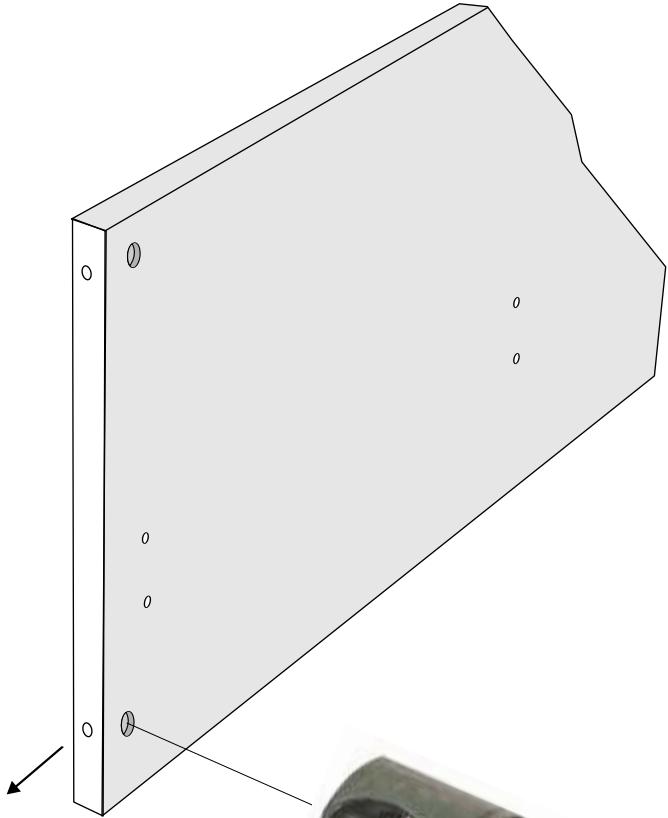
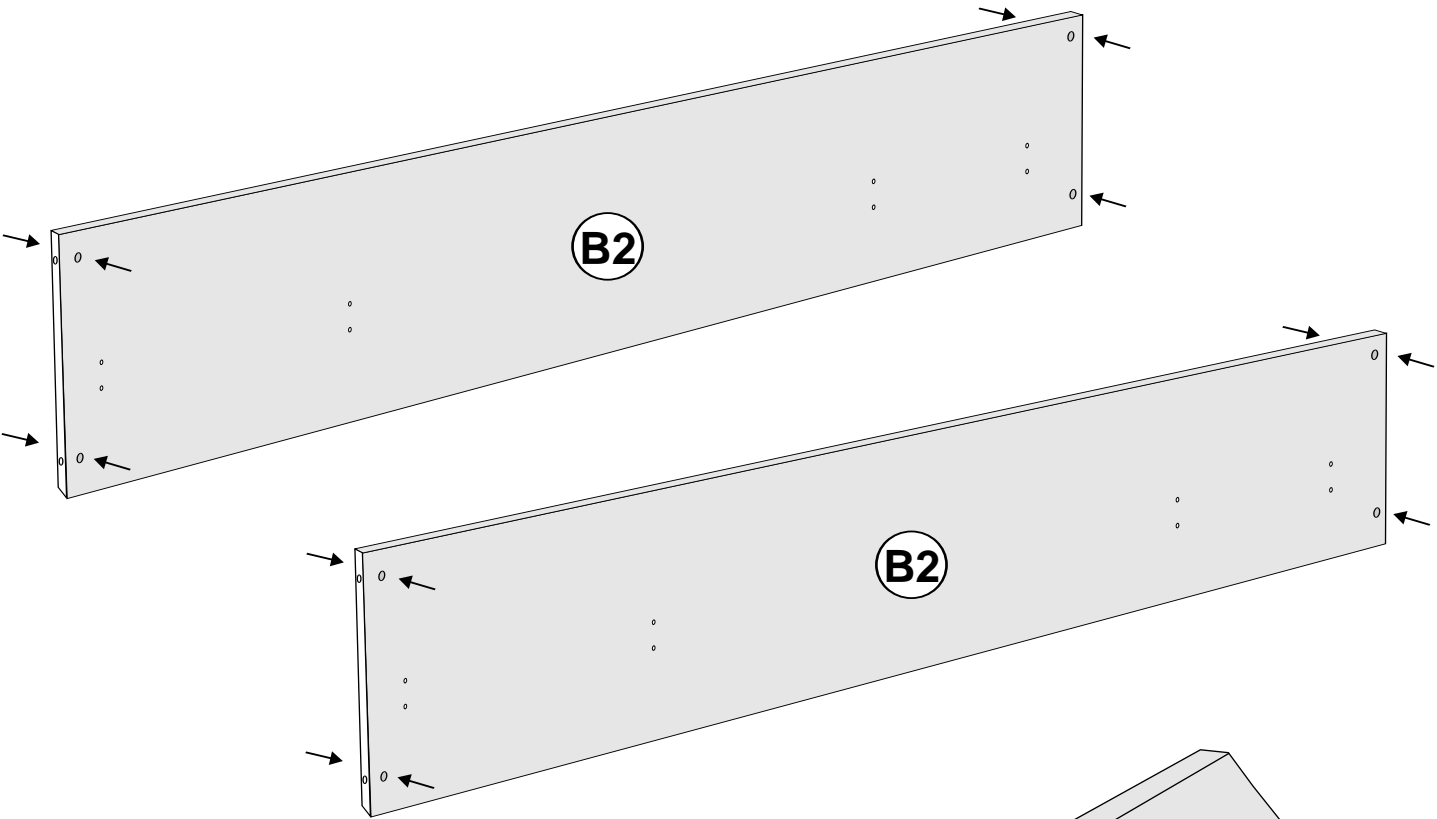

Insert the nut as shown, so that the hole lines up with the hole on the edge of the gable.

STEP 5 Estimated Time: 5 minutes

Insert JRN nuts into the holes on each end of the upper (B3) and lower (B4) stabilizers.

B3 Upper Stabilizers

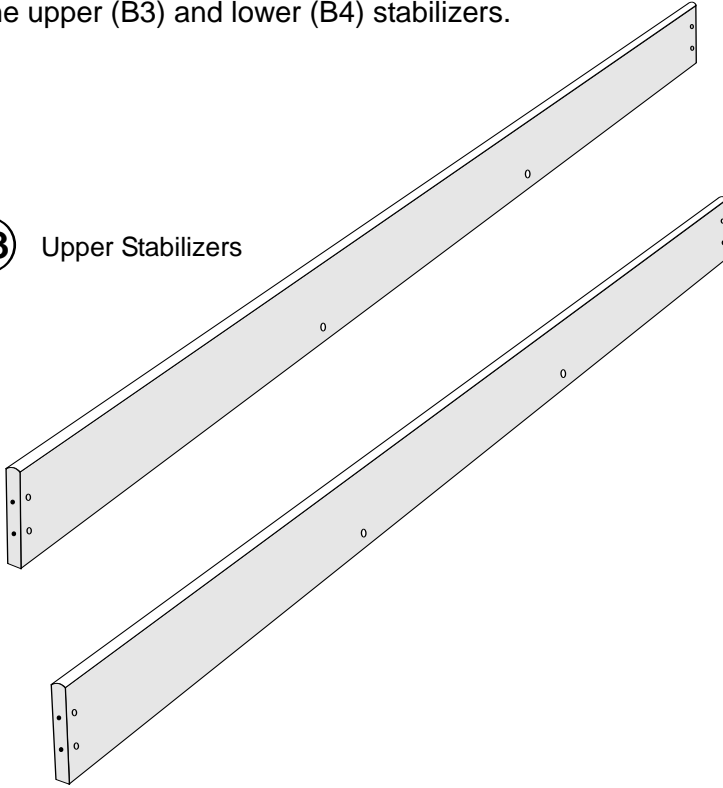

B4 Lower Stabilizers

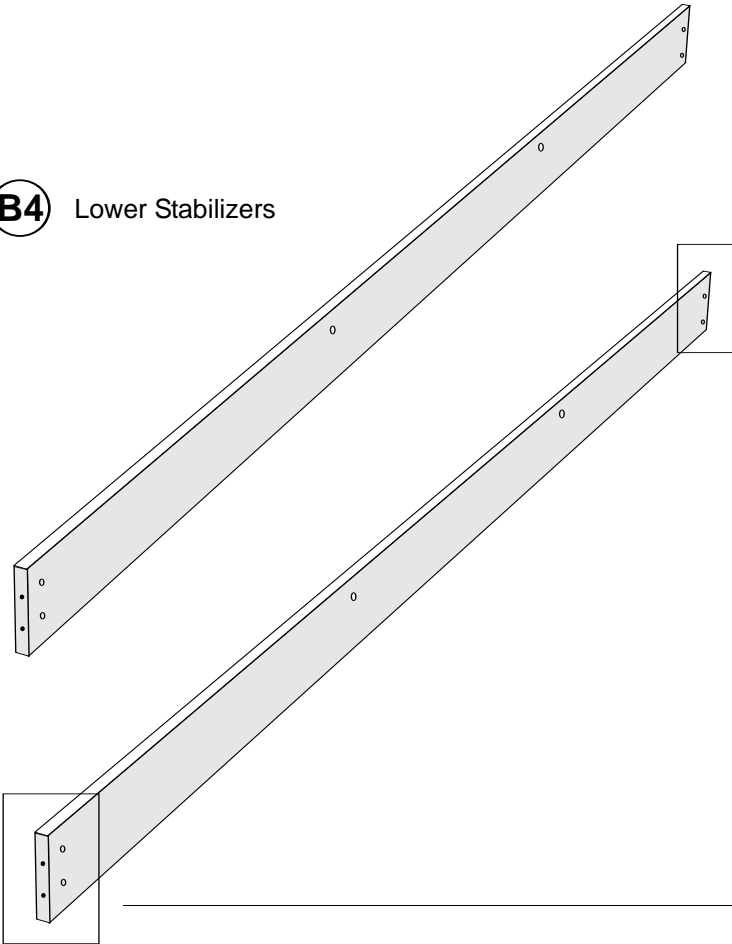

Identifying the upper and lower stabilizers

Upper Stabilizers

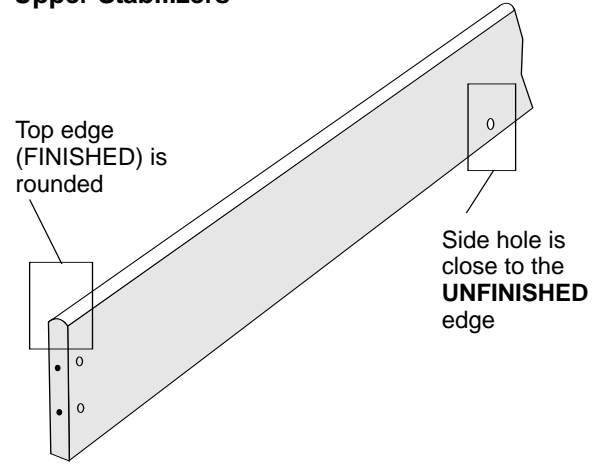

Lower Stabilizers

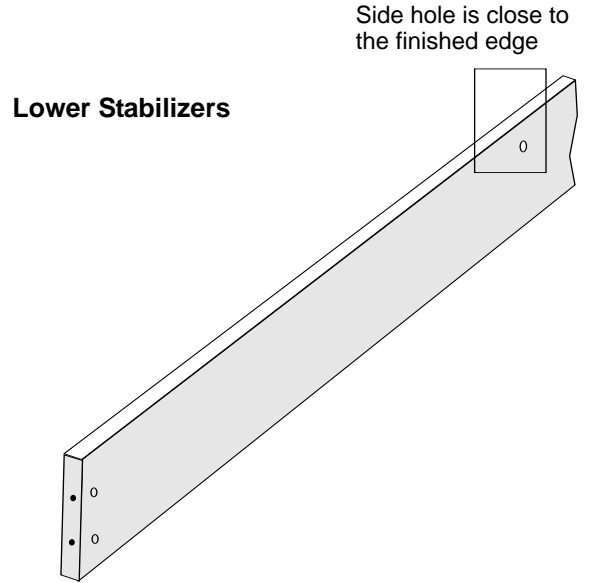

STEP 6 Estimated Time: 10 minutes

Attach "T" spacers and drawer glides to Inner Gables

6a Attach "T" spacers to ONE side of each inner gable with drawer slide screws

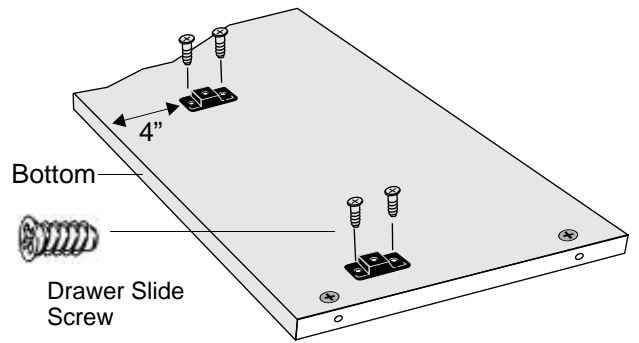

6b Attach drawer glides to "T" spacers on inner gables.

Position the drawer glides with:

- A) The wheel at the finished edge
- B) The wheel on the bottom

IMPORTANT:

Before attaching the drawer glides, determine the TOP and BOTTOM of each inner gable.

A. Measure from each edge of the "T" Spacer to each unfinished edge.

B. The measurement that is approximately 4" will be the **BOTTOM**.

Check the position of the drawer glides carefully before you attach them to the inner gables.

CORRECT

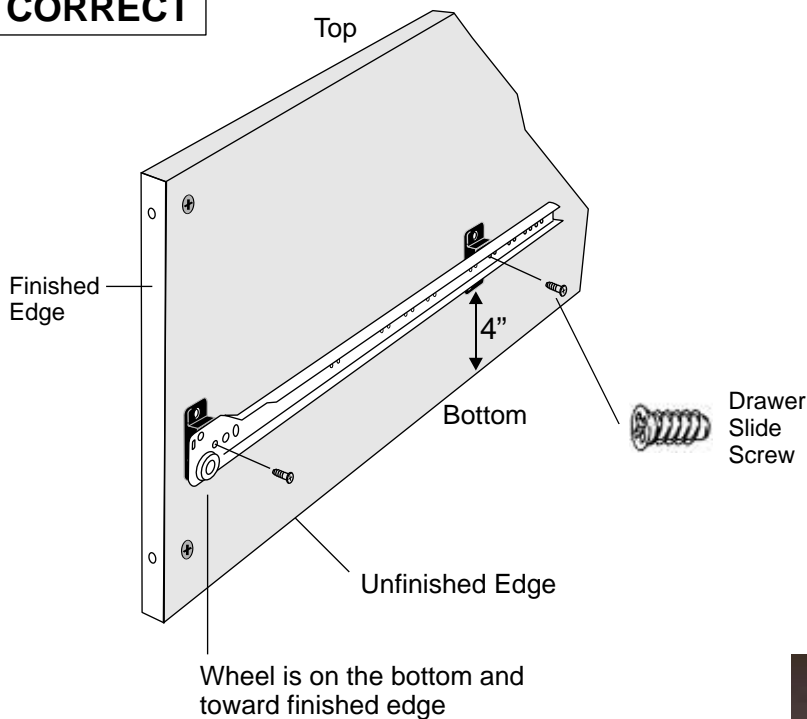

INCORRECT

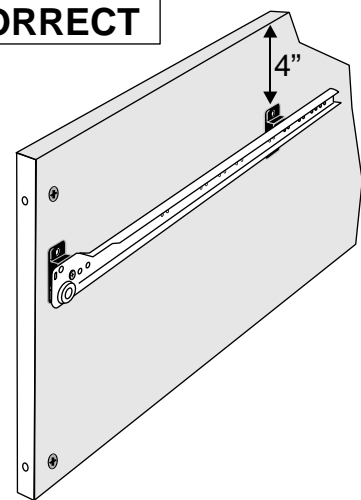

6c Repeat steps 6a & 6b for the 2nd side of the inner gables.



STEP 7 Estimated Time: 5 minutes

Using JCB connectors, and the Allen Key provided, attach each lower stabilizer (B4), one at a time, to both inner gables

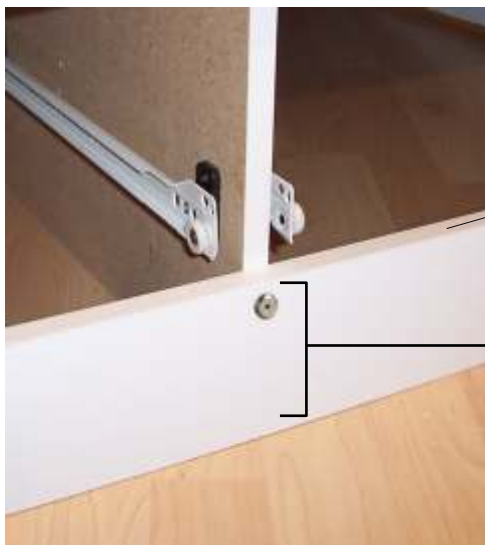
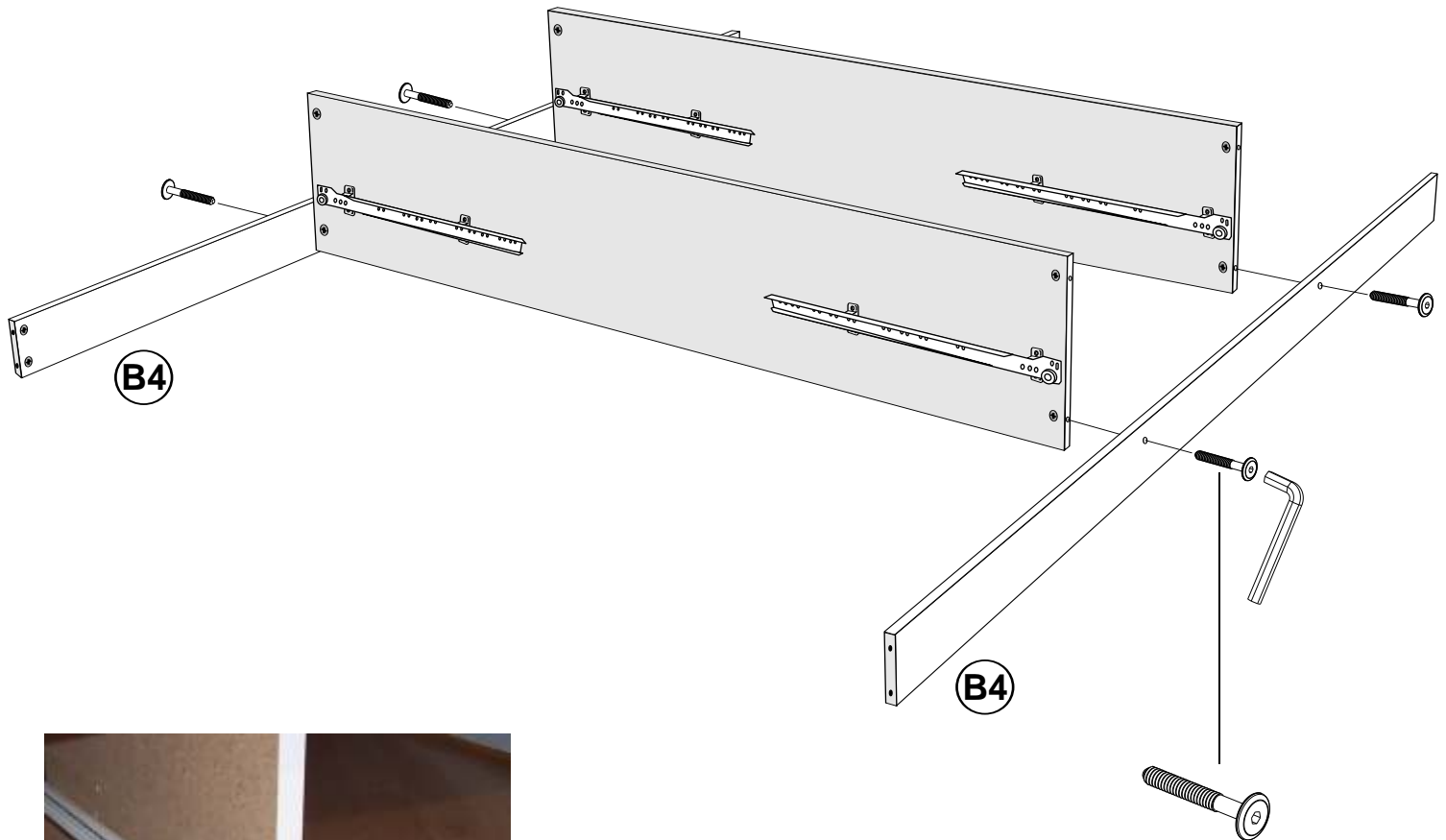

Finished edge

IMPORTANT

Identifying the Lower Stabilizer

The screw hole is at the top, close to the finished edge

If you have any difficulty tightening the JCB connector, use a screwdriver to adjust the JRN nut to make sure the hole is facing the opening for the connector

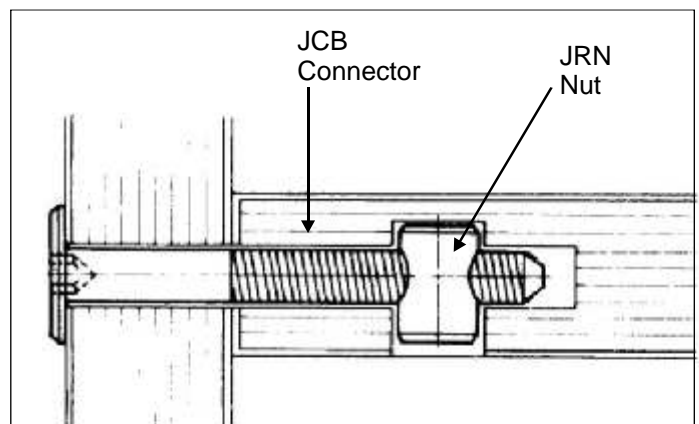

STEP 8 Estimated Time: 5 minutes

Using JCB connectors, attach each upper stabilizer (B3), one at a time, to both inner gables.

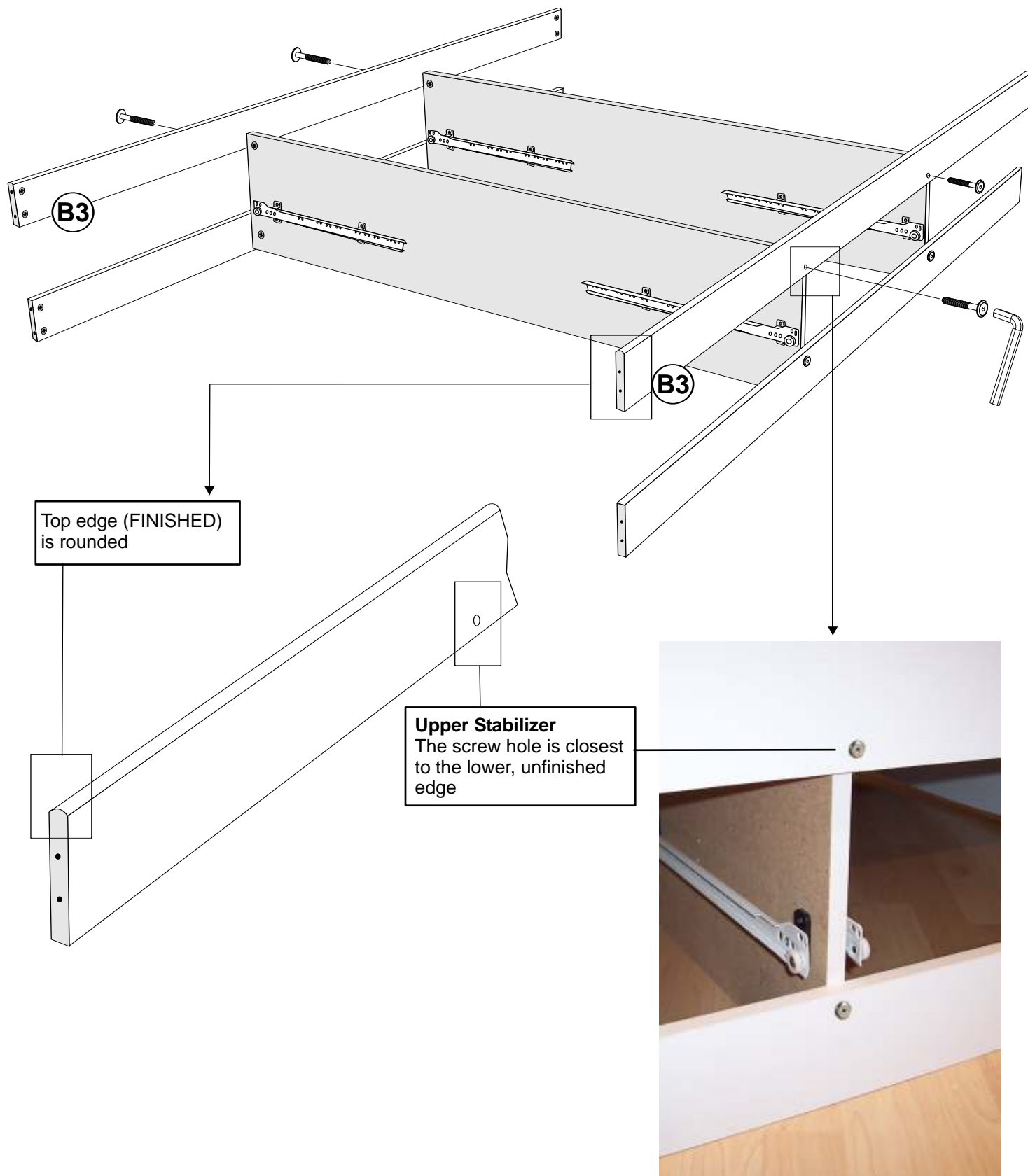

STEP 8 Estimated Time: 10 minutes

Attach one outer gable (B1) to stabilizers with JCB connectors

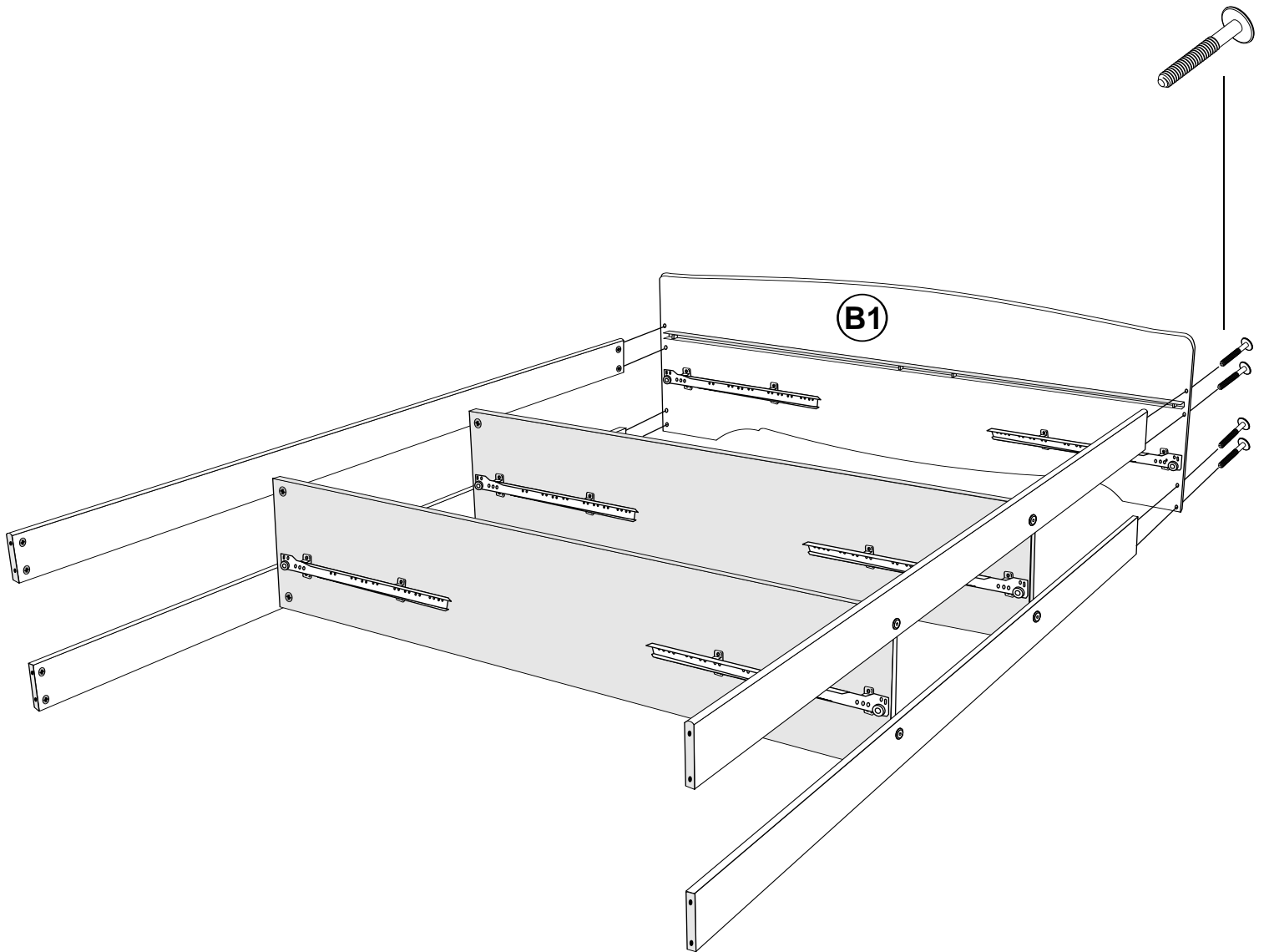

STEP 9 Estimated Time: 5 minutes

9a Spread the wooden slats out across the inner stabilizers

9b Slide the slats into the wide spaces of the metal U-channel (B6) on one outer gable.



9b

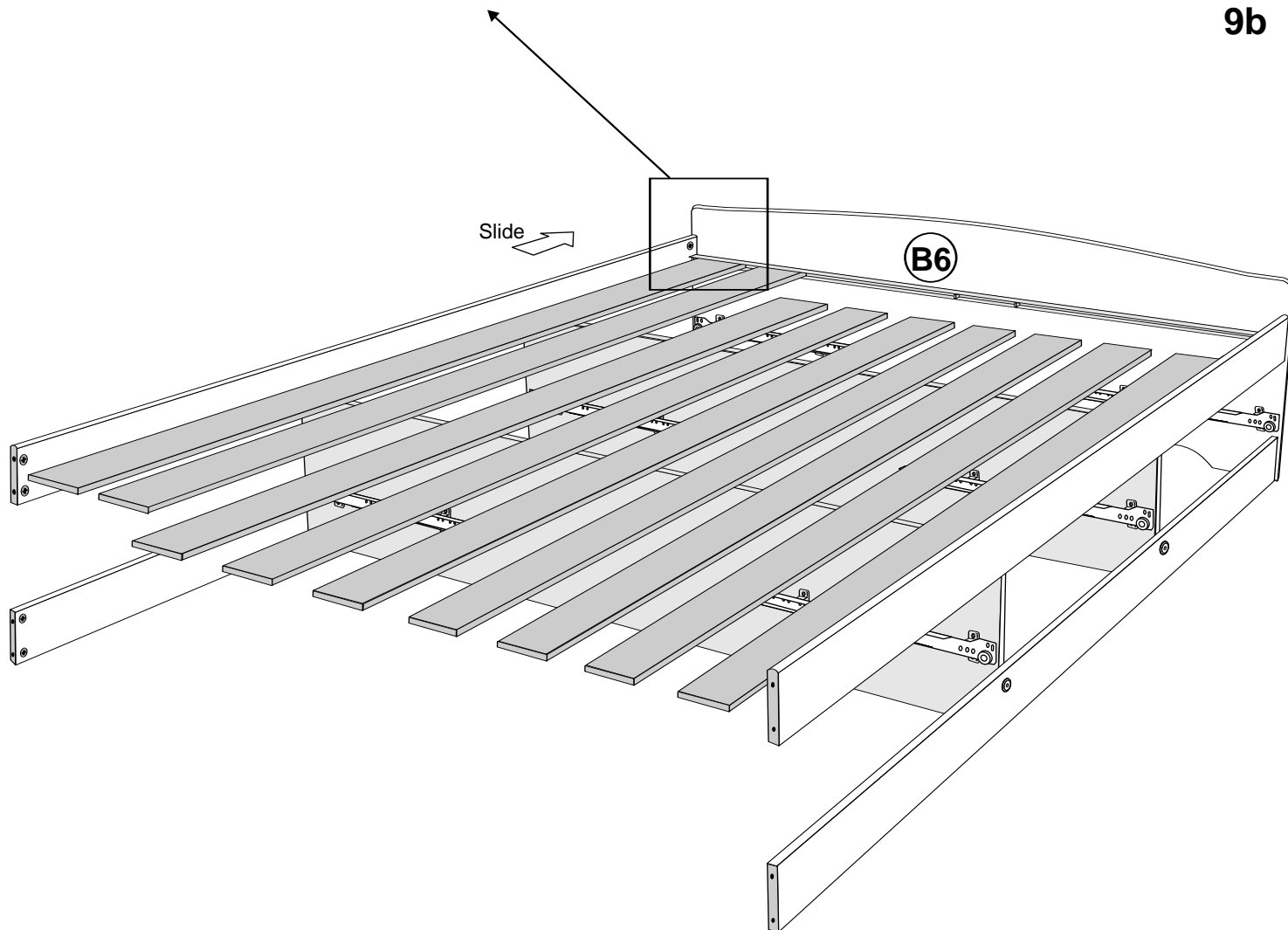

STEP 10 Estimated Time: 10 minutes

Attach second outer gable to stabilizers with JCB connectors

- 10a** Secure the gable in place with connectors, but don't fully tighten
- 10b** Ensure the slats are set inside the u-channel and that they haven't pulled out of the first outer gable.
- 10c** Firmly tighten the connectors

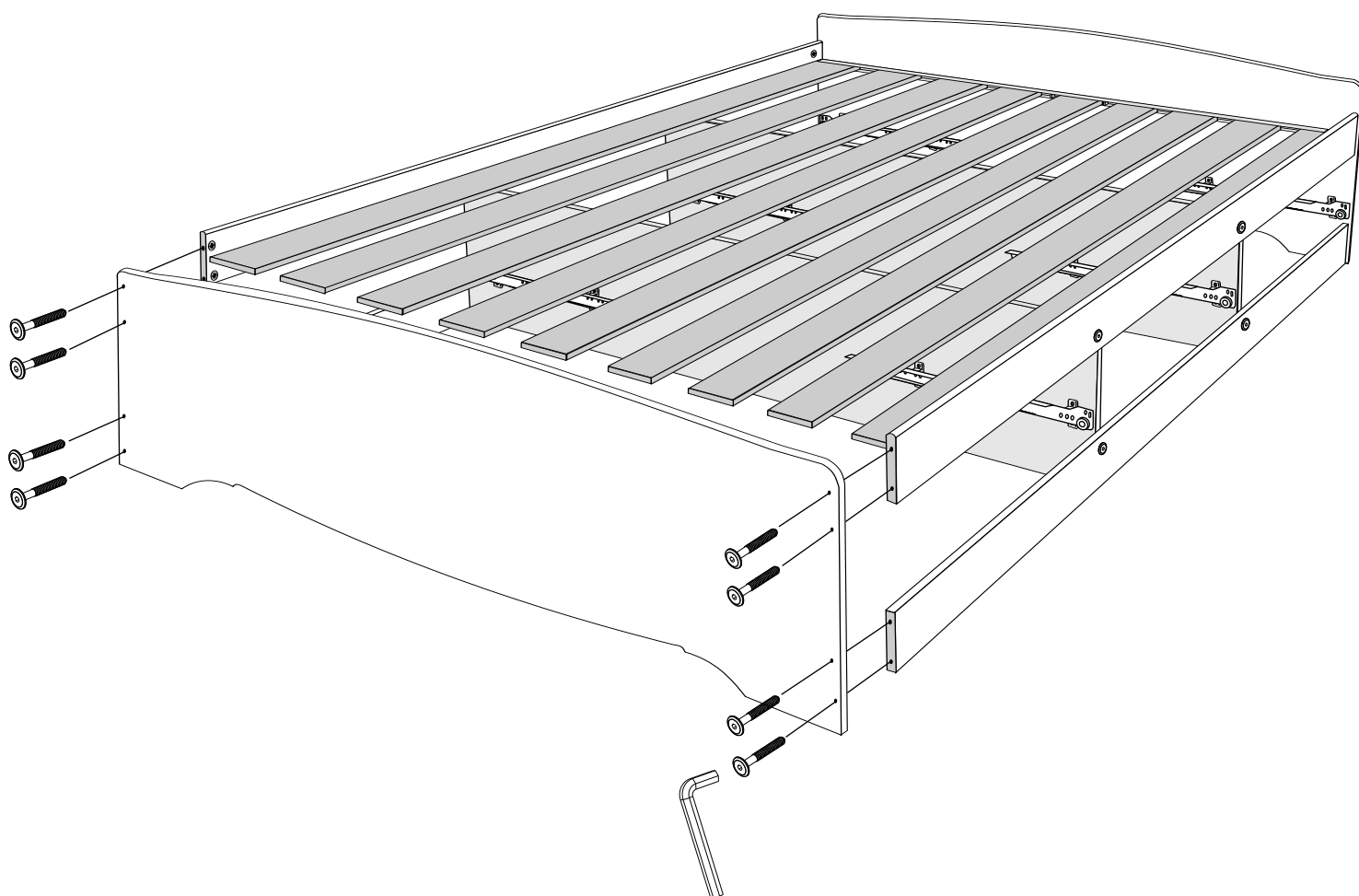

Drawer Parts Identification

D1

Drawer Front (6)
DF-10012-B black
DF-10012-C cherry
DF-10012-E espresso
DF-10012-M maple
DF-10012-W white

D2

Left Drawer Side (6)
DS-0415W-L
 Plywood

D3

Right Drawer Side (6)
DS-0415W-R
 Plywood

D4

Drawer Back (6)
DK-4100W unfinished

D5

Drawer Bottom (6)
DB-4100 unfinished

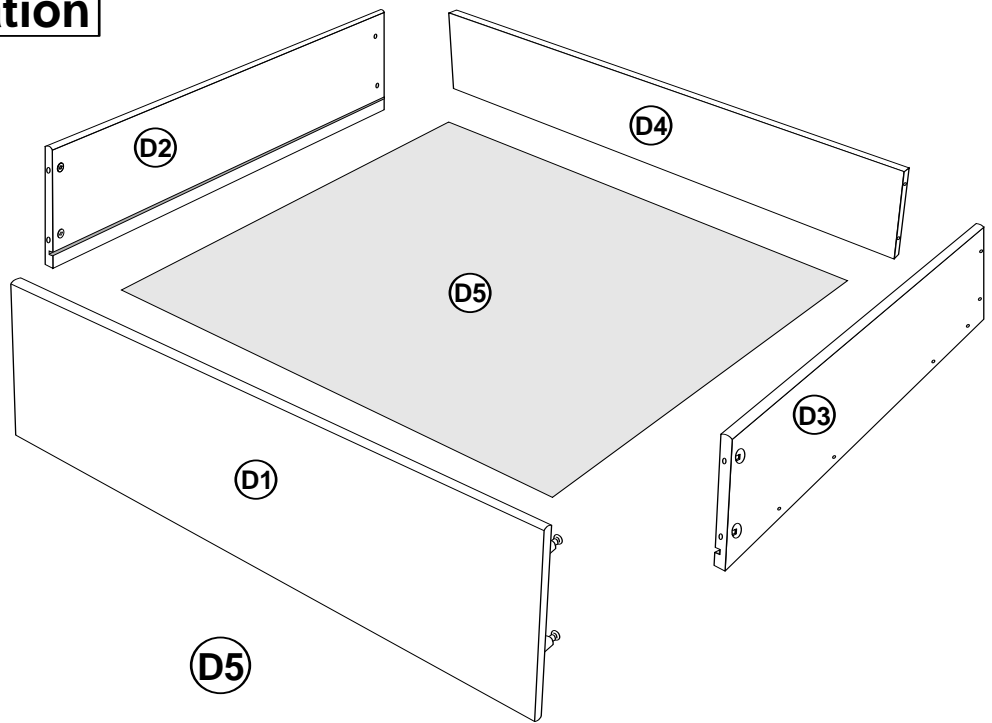

STEP 11 Estimated Time: 5 minutes PER DRAWER

11a Insert cams into drawer sides

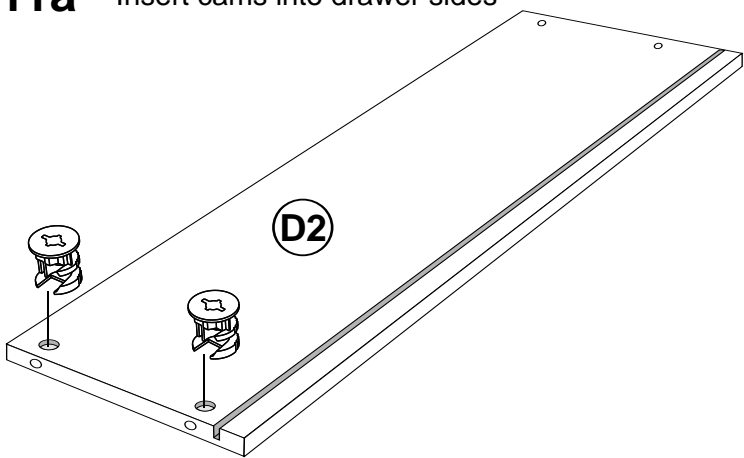

Left Drawer Side

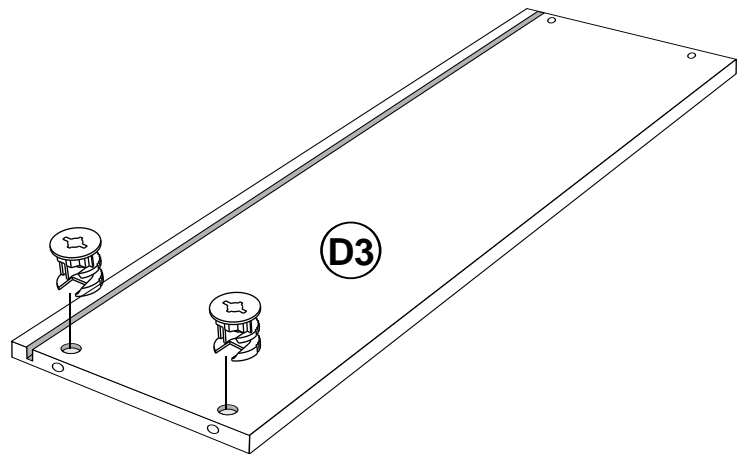

Right Drawer Side

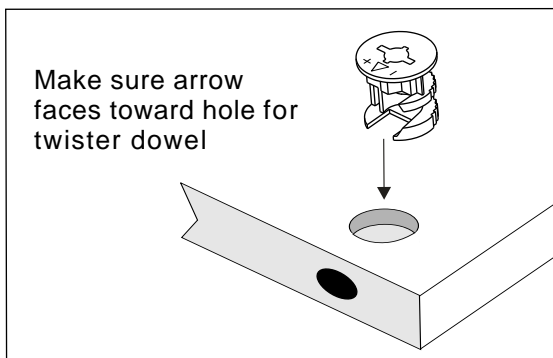

11b Screw black twister dowels into drawer fronts

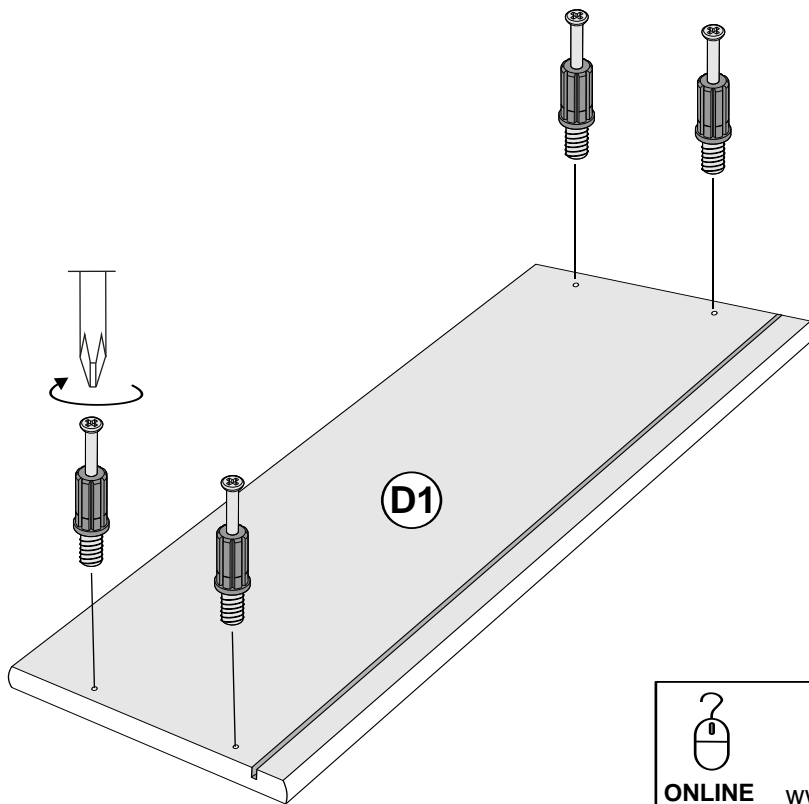

 To see a video showing how the cam and connectors work, please visit our website:
www.prepacmfg.com/support/assemblyvideos.html

ONLINE HELP

11c Attach drawer sides to drawer back with 1½" Hi Lo screws

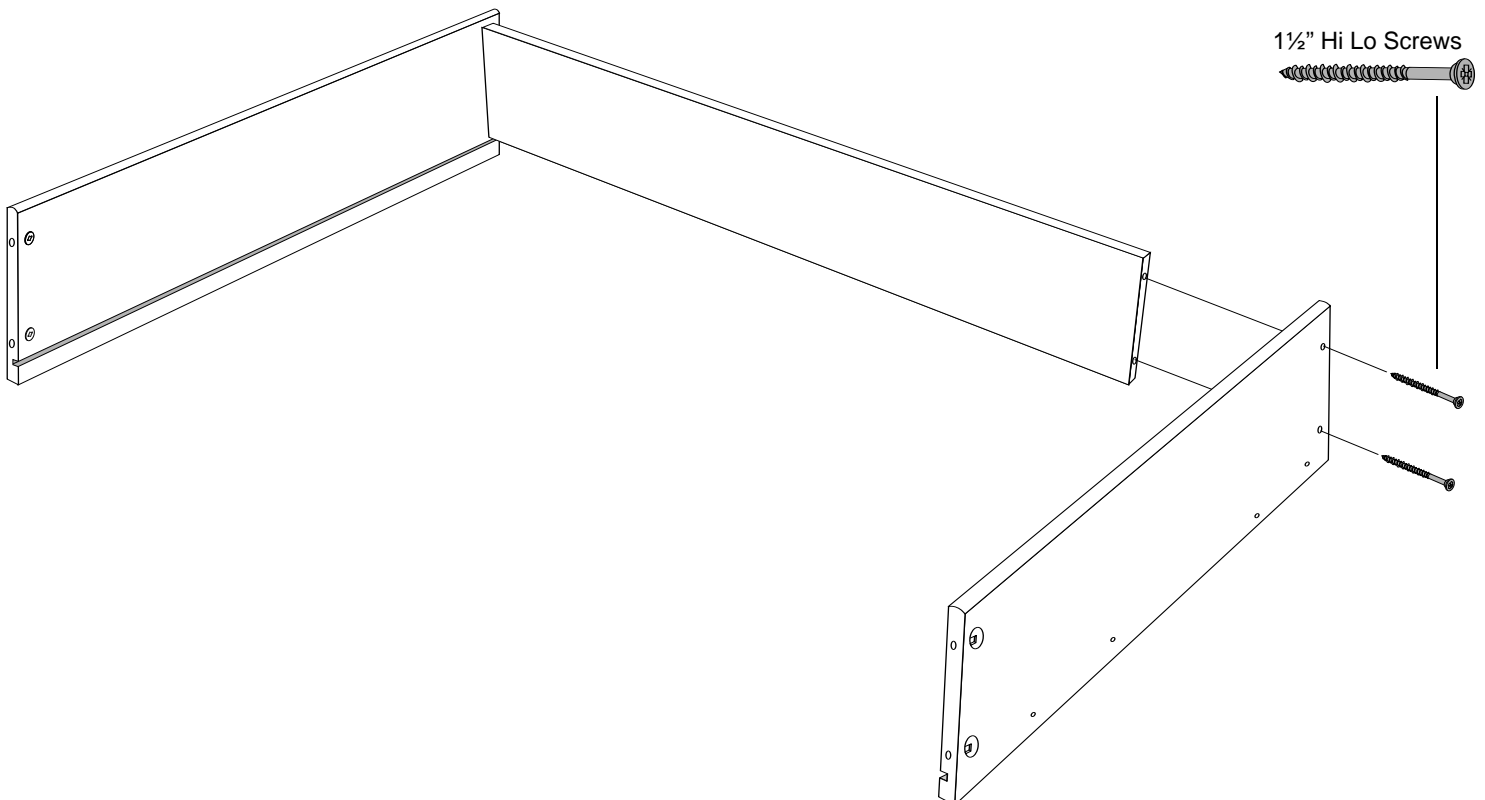

11d Attach drawer front and tighten cams using a flat head screwdriver

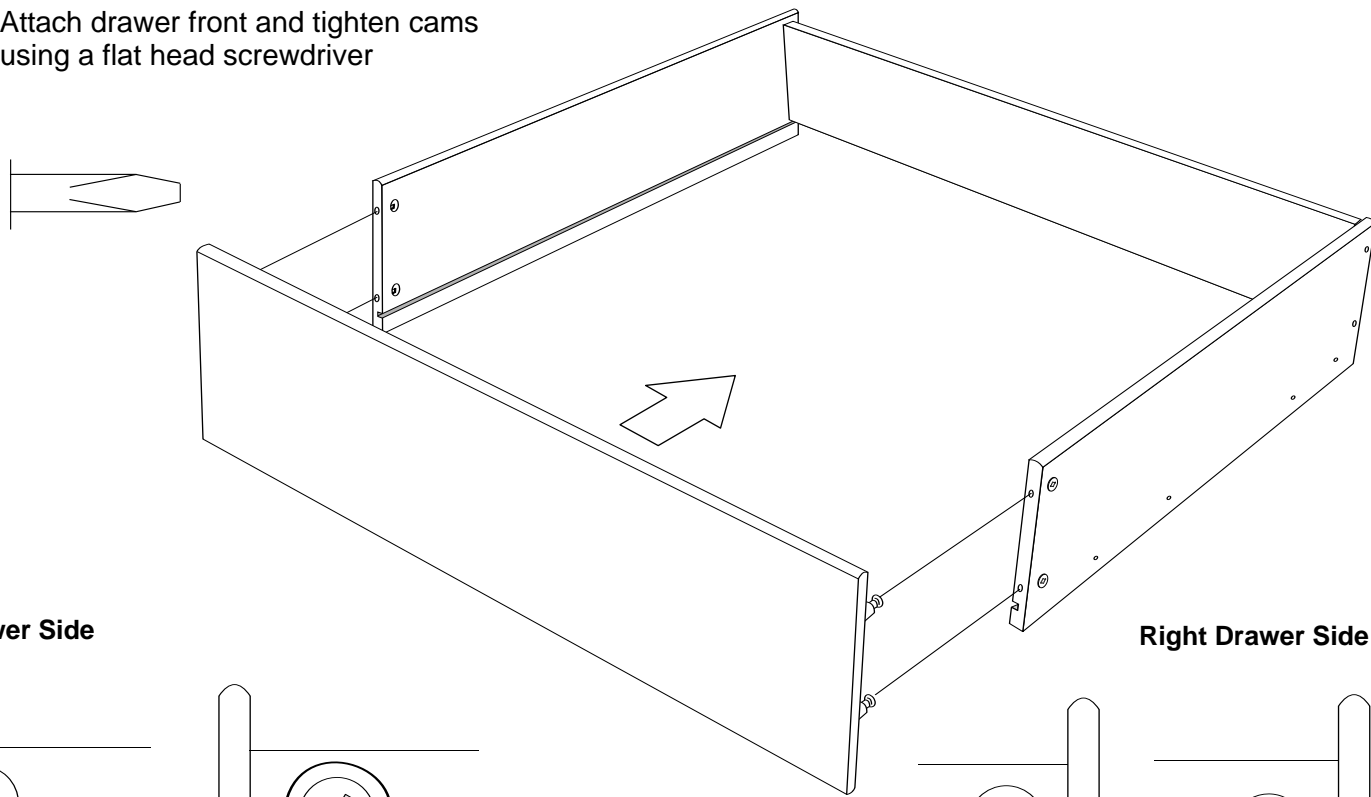

Left Drawer Side

Right Drawer Side

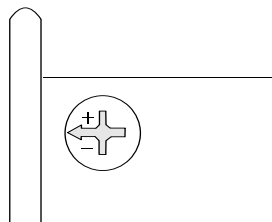

Unlocked

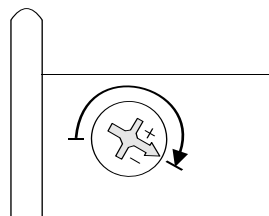

Locked
Turn 210°

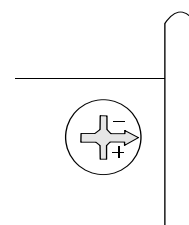

Unlocked

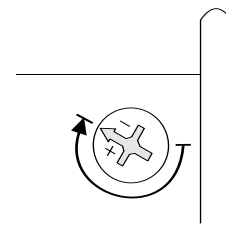

Locked
Turn 210°

11e Turn drawer upside down and slide drawer bottom into grooves

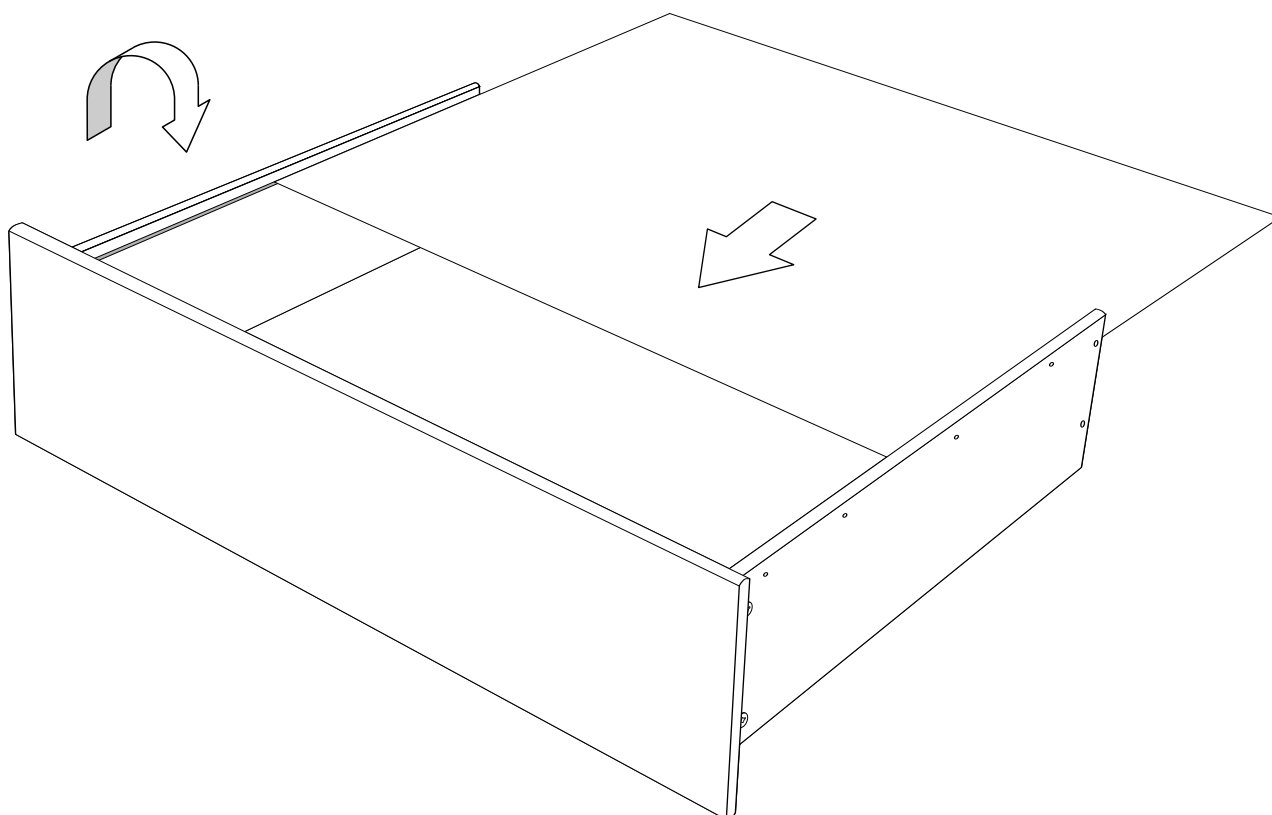

11f Secure the drawer bottom to the drawer back with nails

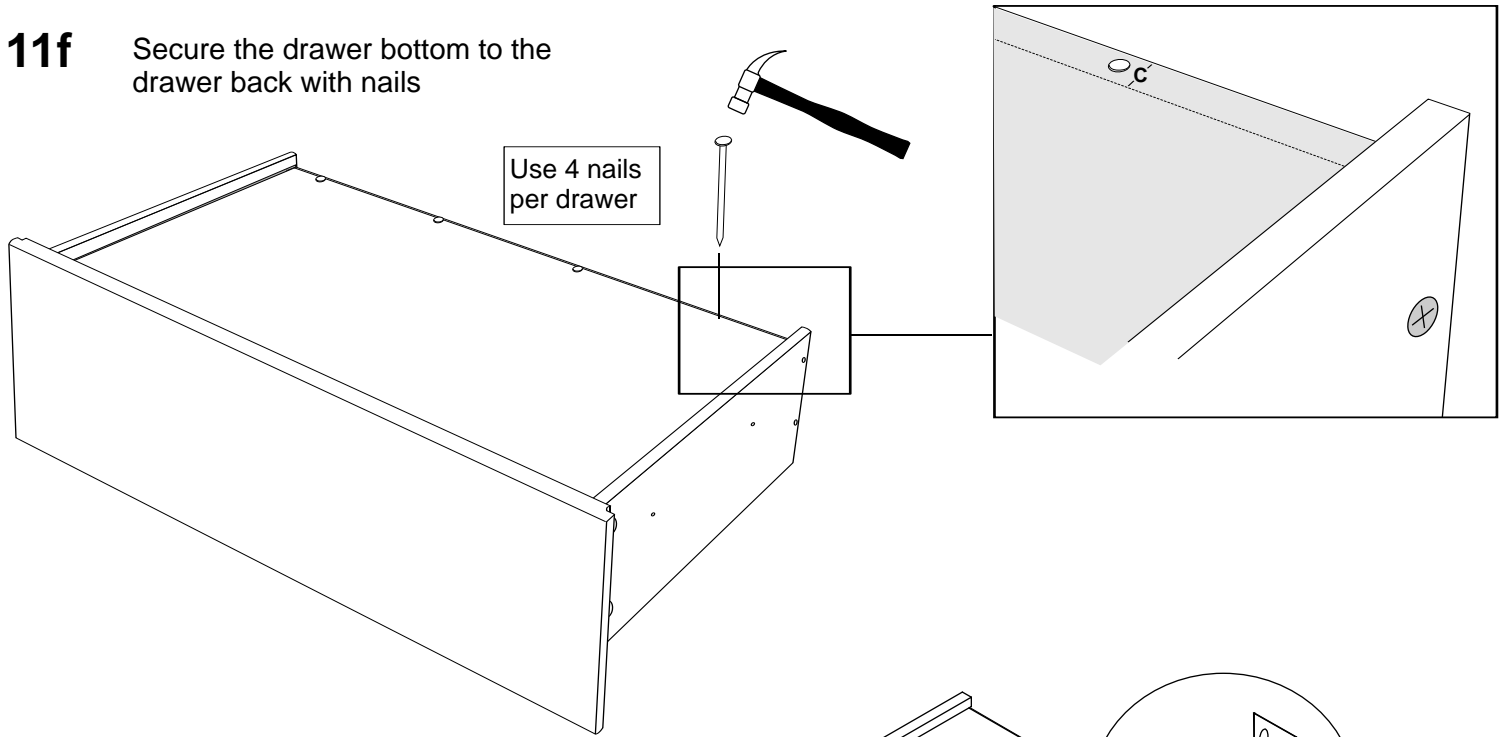

11g Insert the Drawer Bottom Stabilizer

Position the Stabilizer in the center of the drawer and insert it into the groove on the drawer front. This is the same groove that you inserted the drawer bottom into.

Then, tighten screw until it is flush

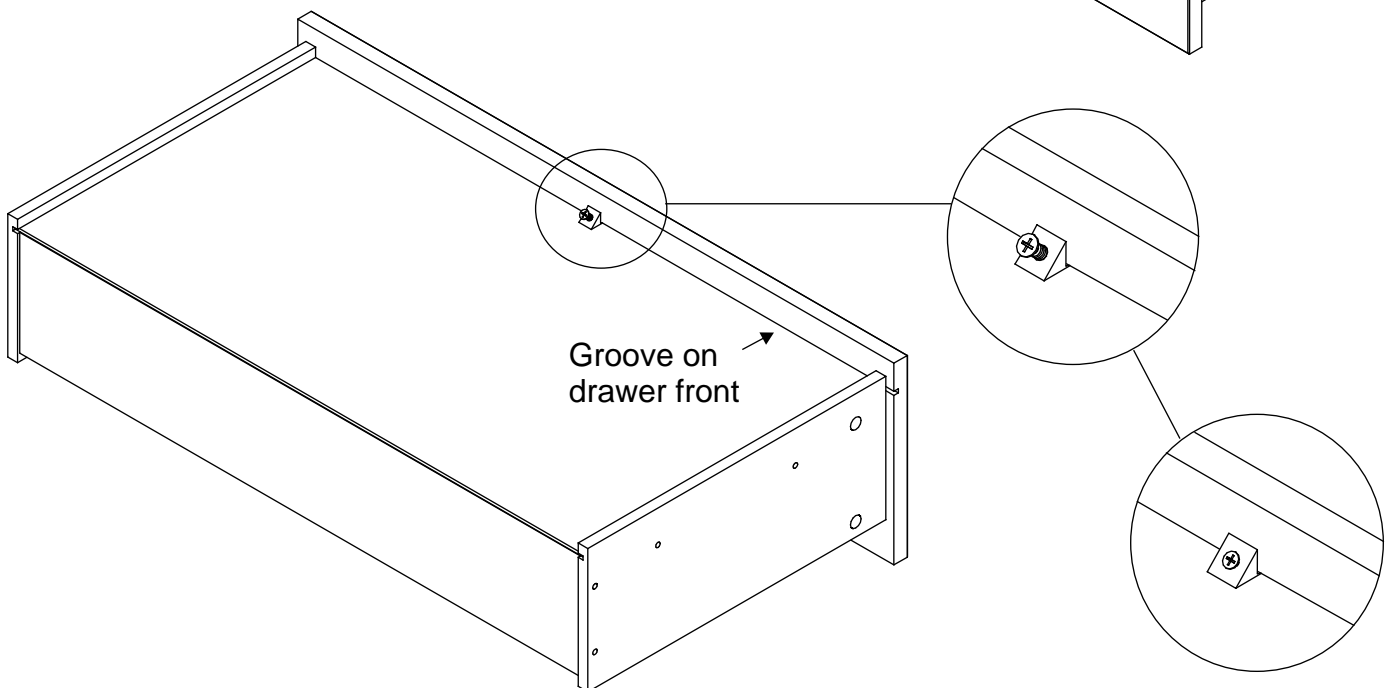
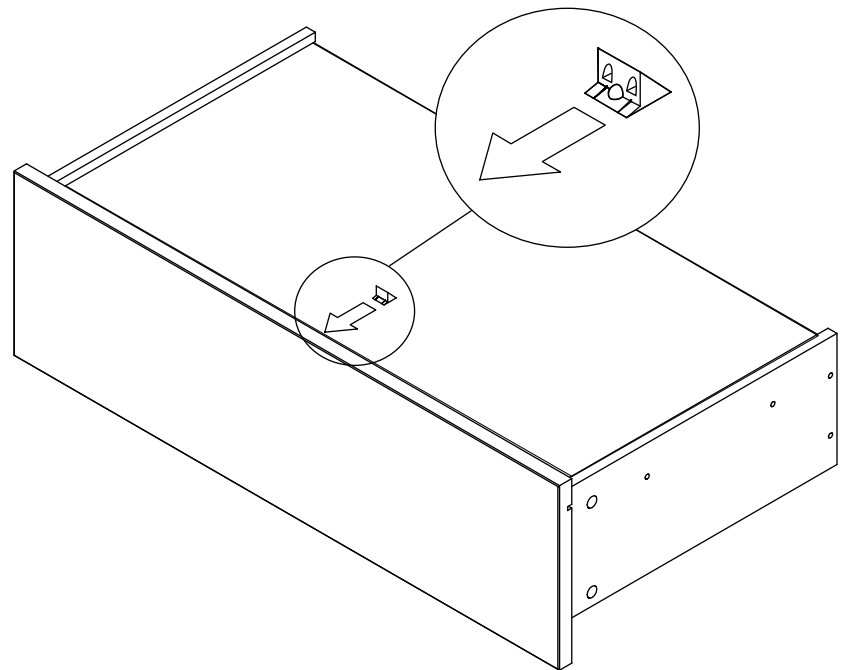

11h Attach drawer slides to left and right drawer sides using drawer slide screws

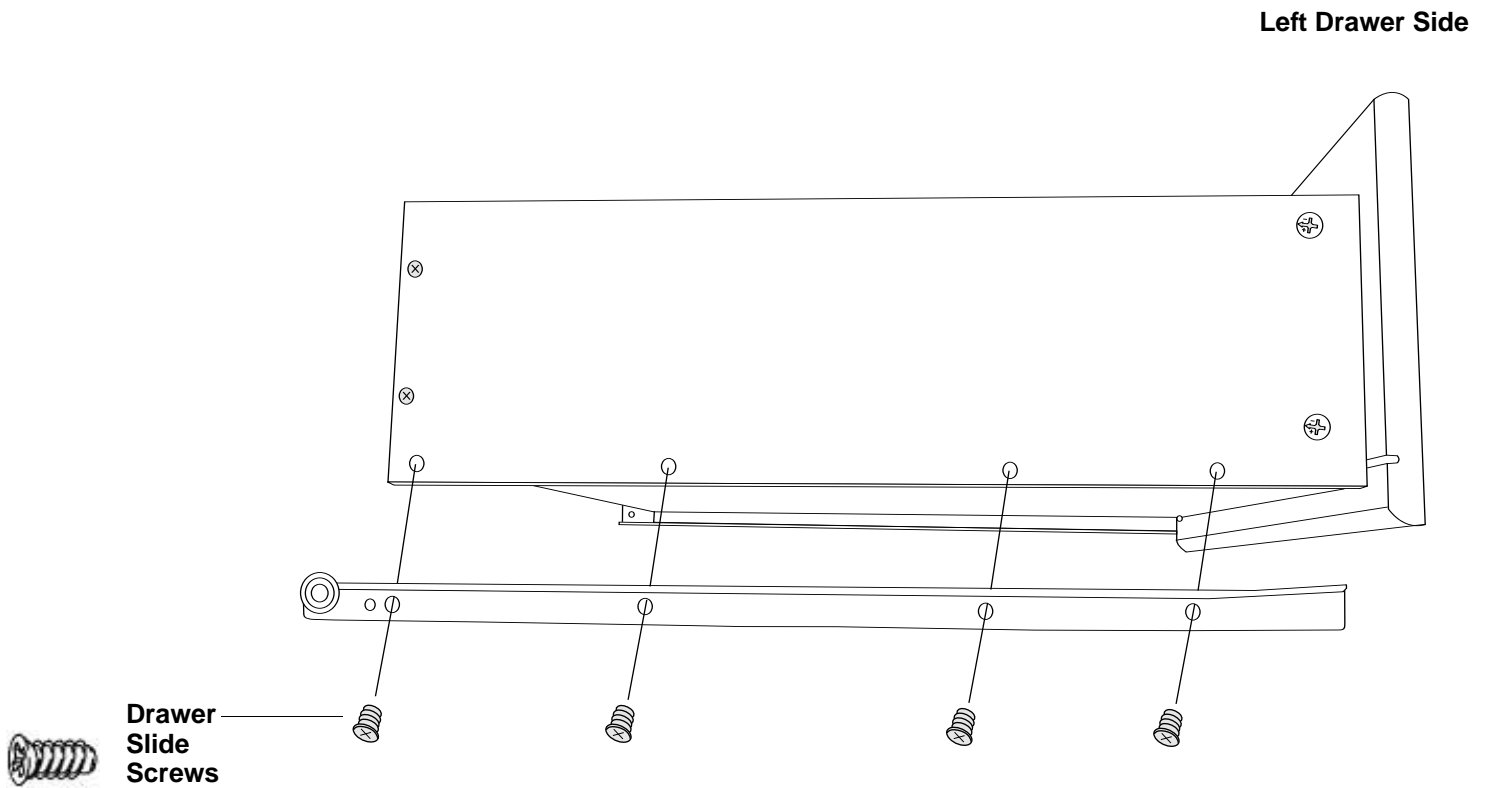
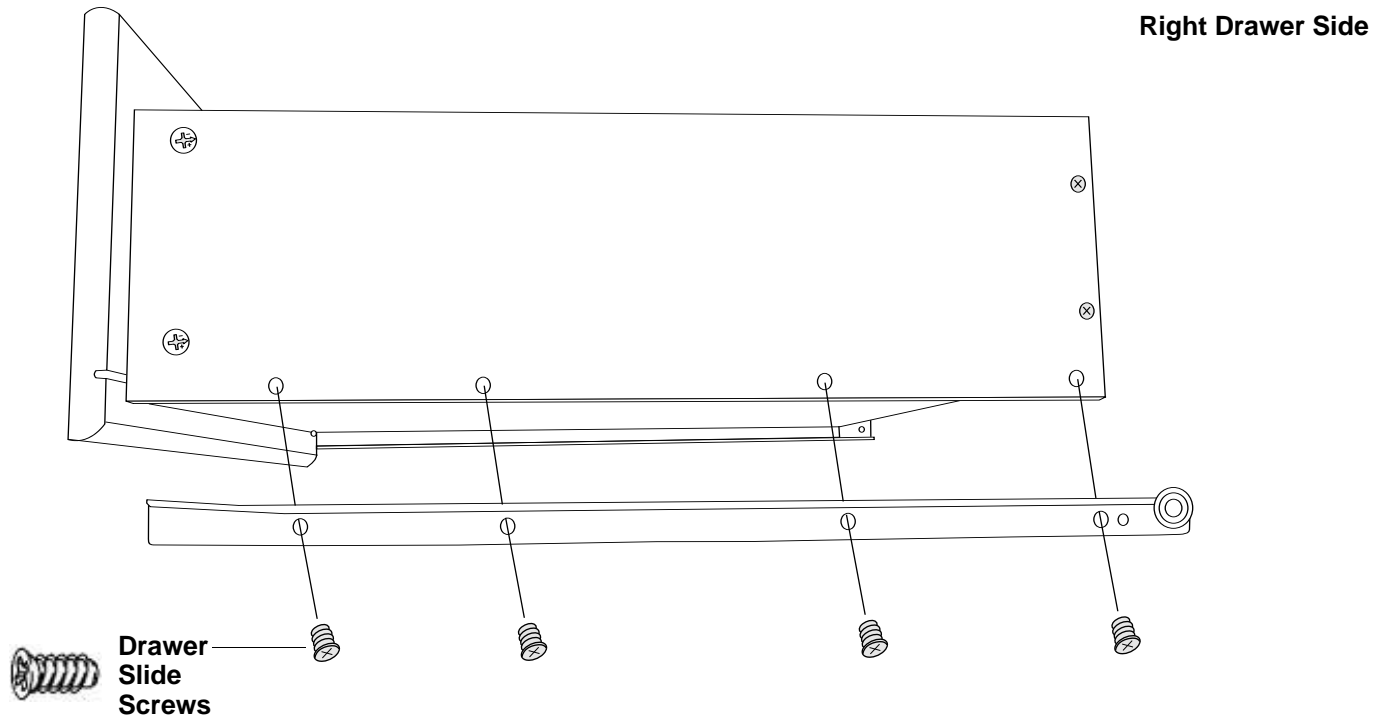

STEP 12 Estimated Time: 2 minutes

Insert drawers

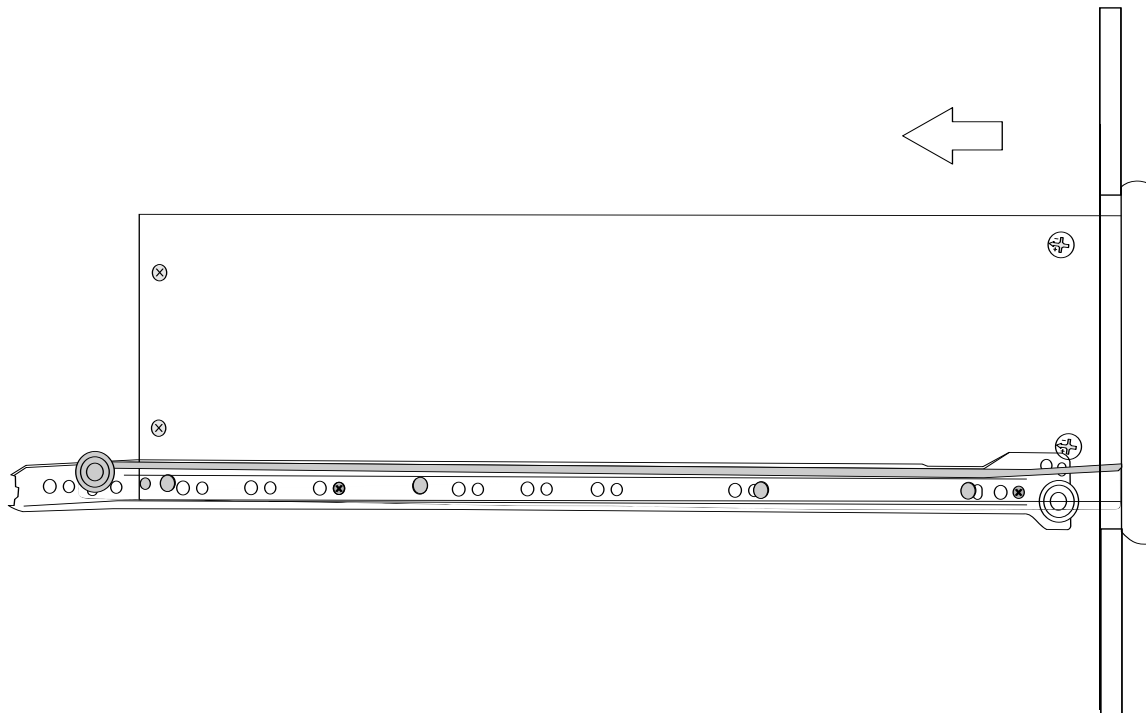
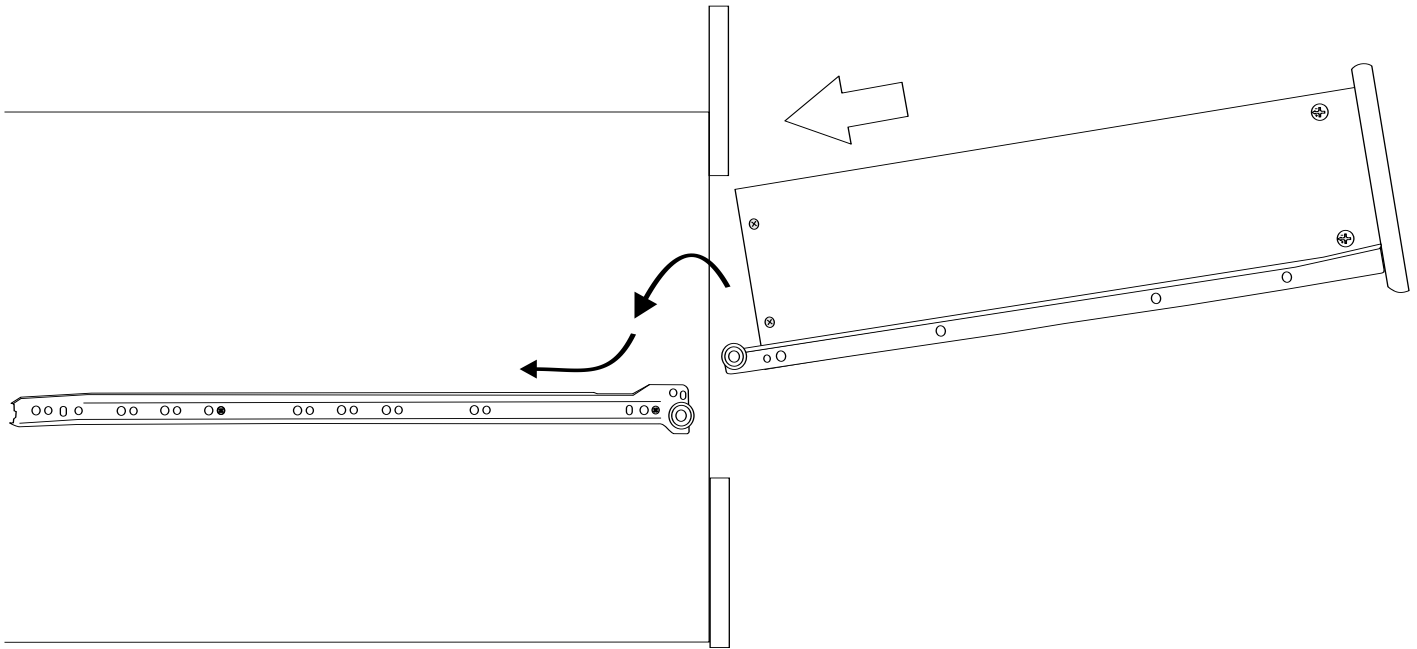

Note: When drawers are installed correctly, you will not be able to remove them without first lifting up the drawer front.



Furniture Care Q&A

Q. How do I clean your products?

A. We recommend that you simply wipe your products with a clean, damp cloth and then dry immediately with another clean cloth to maximize the life span and look of your unit

Q. Can I paint or varnish your products?

A. Our products are made from durable composite woods with a laminate finish and therefore should not be painted or varnished.

Q. Are they waterproof?

A. NO. If liquid is spilled and quickly wiped up, no damage will be done to your product. However, continuous exposure to liquids or high humidity may cause damage to the board.

Give Us Your Feedback



CALL US

1-877-PREPAC1 (1-877-773-7221)
Mon - Fri 7am - 4pm PST
10am - 7pm EST

Email Us: assembly@prepacmfg.com

Thanks!