

Installation Instructions

Elkay Explore Fine Fireclay Undermount Sinks

CAREFULLY READ THESE INSTRUCTIONS BEFORE YOU BEGIN

ATTENTION INSTALLER

- ELKAY recommends that Fine Fireclay sinks should be installed by a professional experienced installer.
- Before installation, please inspect the sink for damage. Do not install a damaged sink.
- **WARNING:** Due to the dimensional variation inherent in the fine fireclay manufacturing process, sink cutout templates are not provided. Elkay recommends using the actual sink for the countertop cutout. It is recommended that you discuss with your customer the desired finished appearance of the sink and countertop installation. Elkay is not responsible for improper sink and/or countertop installations.
- It is recommended that you discuss with your customer and agree to what the finished effect will be. Elkay is not responsible for improper sink or countertop installations.
- Elkay Fireclay undermounts must be fastened to solid surface countertops only (i.e., granite).
- Elkay is not responsible for sink and countertop if damaged during installation.
- Fireclay sinks are heavy, please arrange for assistance to move or position.
- Follow all local plumbing and building codes.

Fireclay Farmhouse Apron Undermount Sink Only

- A custom sink base cabinet is required.
- Proper installation requires a coordinated effort including advanced dialog between the designer (or customer), the cabinet maker, the countertop fabricator and the sink installer during the design and installation phase.
- Elkay recommends providing the cabinet maker with the actual sink to be installed prior to cabinet fabrication.
- It is **required** that a support frame be constructed inside the cabinet for adequate support of the sink as shown in Figure 1. Shim as necessary to the appropriate height.
- **Warning:** The support frame and proper support for the sink must sufficiently support 300 lbs. This is the approximate weight of the sink when full.
- Templates are not included however it is recommended that the sink countertop cutout provide a 1/4" reveal as shown in Figure 2.

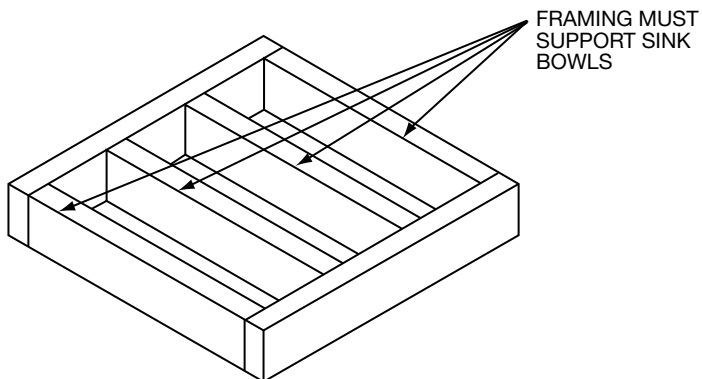

FIGURE 1

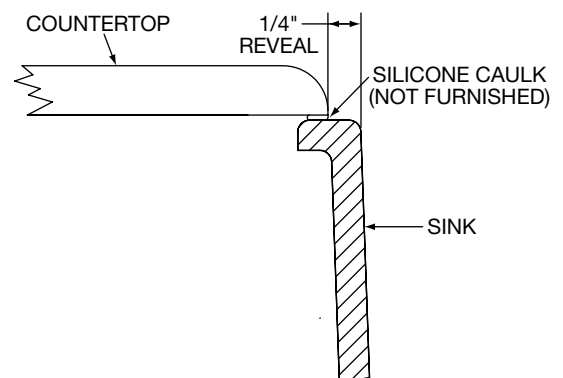

FIGURE 2

Fireclay Undermount Sinks

- Elkay recommends providing the cabinet maker with the actual sink to be installed prior to cabinet fabrication.
- It is **required** that a support frame be constructed inside the cabinet for adequate support of the sink as shown in Figure 1.
- **Warning:** The support frame and proper support for the sink must sufficiently support 300 lbs. This is the approximate weight of a sink when full.
- Templates are not included however it is recommended that the sink countertop cutout provide a 1/8" overhang into the sink bowl opening as shown in Figure 3. Do not reduce this 1/8" dimension since the bowl shape and overall size will have dimensional variation.

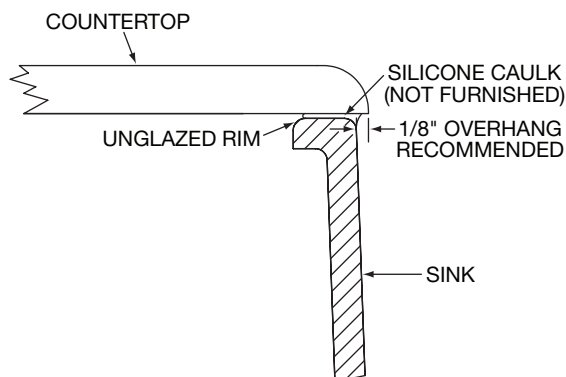

FIGURE 3

Care and Cleaning Guide

Elkay Fireclay was created for a lifetime of easy care. Just follow the simple guidelines listed below.

Routine Care

Most dirt & stains:

Use soapy water or vinegar-based cleaner and a sponge and towel dry.

Water marks:

Wipe with damp cloth and towel dry.

Difficult Stains:

50/50 water/bleach solution or non-abrasive cleaners. Follow cleaning manufacturer's instructions, rinse thoroughly and towel dry.

Preventing Damage

Avoid exposing Elkay Fireclay to strong chemicals, such as paint removers, oven cleaners, etc. If contact occurs, quickly flush the surface with water. Do not use a straight or undiluted bleach solution.

Do not set hot pans directly into sinks

Run cold water when pouring boiling water into sinks.

Do not use any abrasive cleaning products, scouring pads or steel wool.

Do not use caustic solutions containing ammonia or alkalis.

ELKAY LIMITED FIRECLAY SINK WARRANTY

Elkay warrants to the original purchaser of an Elkay Fireclay sink that Elkay will, at its option, replace or repair, without charge, such product if it fails due to a manufacturing defect for a period of 1 year of normal residential use. Product replacement does not include transportation cost or labor installation cost. This warranty covers only Fireclay undermount sinks installed in a conventional solid surface countertop and applies to residential installations only. Elkay reserves the right to examine product in question and its installation prior to replacement.

WASTE FITTINGS AND ACCESSORIES ARE NOT WARRANTED

OTHER WARRANTY CONDITIONS ON SINKS

This warranty applies to sinks purchased after April 1st 2008 as shown on the purchaser's dated receipt. Our warranty does not cover product failure or damage caused by the use of optional Elkay accessories, abusive treatment, misuse, environmental factors, normal wear including surface dulling and scratches, improper care and cleaning, use of aggressive and abrasive cleaners, damage due to handling or failure to follow the recommended procedures for installation, care and maintenance as detailed in the installation and care guide provided with every sink. This warranty is extended only to the original consumer purchaser of the product. This warranty does not cover shipping costs, labor costs, or any other charges for such items as installation or replacement of the sink, diagnosis or replacement of any faucet or component part, or any other expense or loss.

All incidental or consequential damages are specifically excluded. No additional warranties, express or implied are given, including but not limited to, any implied warranty of merchantability or fitness for a particular purpose.

Some states do not allow the exclusion or limitation of incidental or consequential damages or limitations on how long an implied warranty lasts, so the above limitations or exclusions may not apply to you.

This warranty gives you specific legal rights, and you may also have other rights which vary from state to state.

TO OBTAIN SERVICE UNDER WARRANTY

1. Write to: Elkay Manufacturing Company
Attention: Consumer Services
2222 Camden Court
Oak Brook, IL 60523
2. Include a letter containing the following information:
 - a. Date of purchase and installation
 - b. Proof of Purchase (copy of original dated invoice)
 - c. Description of nature of defect
 - d. Model number or description of model and/or component part if possible.